

**DEPARTMENT OF ENVIRONMENTAL QUALITY
AIR QUALITY DIVISION**

**Permit Application Analysis
AP-5873**

June 19, 2008

NAME OF FIRM:	Medicine Bow Fuel & Power, LLC
NAME OF FACILITY:	Medicine Bow Industrial Gasification and Liquefaction (IGL) Plant
FACILITY LOCATION:	Section 29, T21N, R79W Carbon County, Wyoming 390,750 m E; 4,624,303 m N (UTM Zone 12, NAD 27)
TYPE OF OPERATION:	Coal Gasification and Liquefaction
RESPONSIBLE OFFICIAL:	Jude R. Rolfes, Senior Vice President
MAILING ADDRESS:	Two Riverway, Suite 1780 Houston, TX 77056
TELEPHONE NUMBER:	(713) 425-6526
REVIEWERS:	Andrew Keyfauber, NSR Permit Engineer James (Josh) Nall, Air Quality Meteorologist

PURPOSE OF APPLICATION:

Medicine Bow Fuel & Power, LLC (MBFP) submitted an application to construct an underground coal mine and industrial gasification and liquefaction (IGL) plant that will produce transportation fuels and other products. The underground coal mine (Saddleback Hills Mine) is expected to have a maximum production rate of 8,700 tons per day (TPD) of coal or approximately 3.2 million tons per year (MMTPY) of coal as feed to the IGL Plant. The plant will gasify coal to produce synthesis gas (syngas) to produce the following products:

- 18,500 barrels per day (bpd) of gasoline
- 42 tons per day of sulfur
- 198 million standard cubic feet per day (MMscfd) of carbon dioxide (CO₂)
- 712 tons per day of coarse slag

PROCESS DESCRIPTION:

The following contains a general description of the processes at the Medicine Bow IGL plant, and a block flow diagram is shown in Figure 1.

**MEDICINE BOW
EXHIBIT HH
PRE-HRG MEMO**

DEQ 000506

Figure 1 - Process Flow Diagram

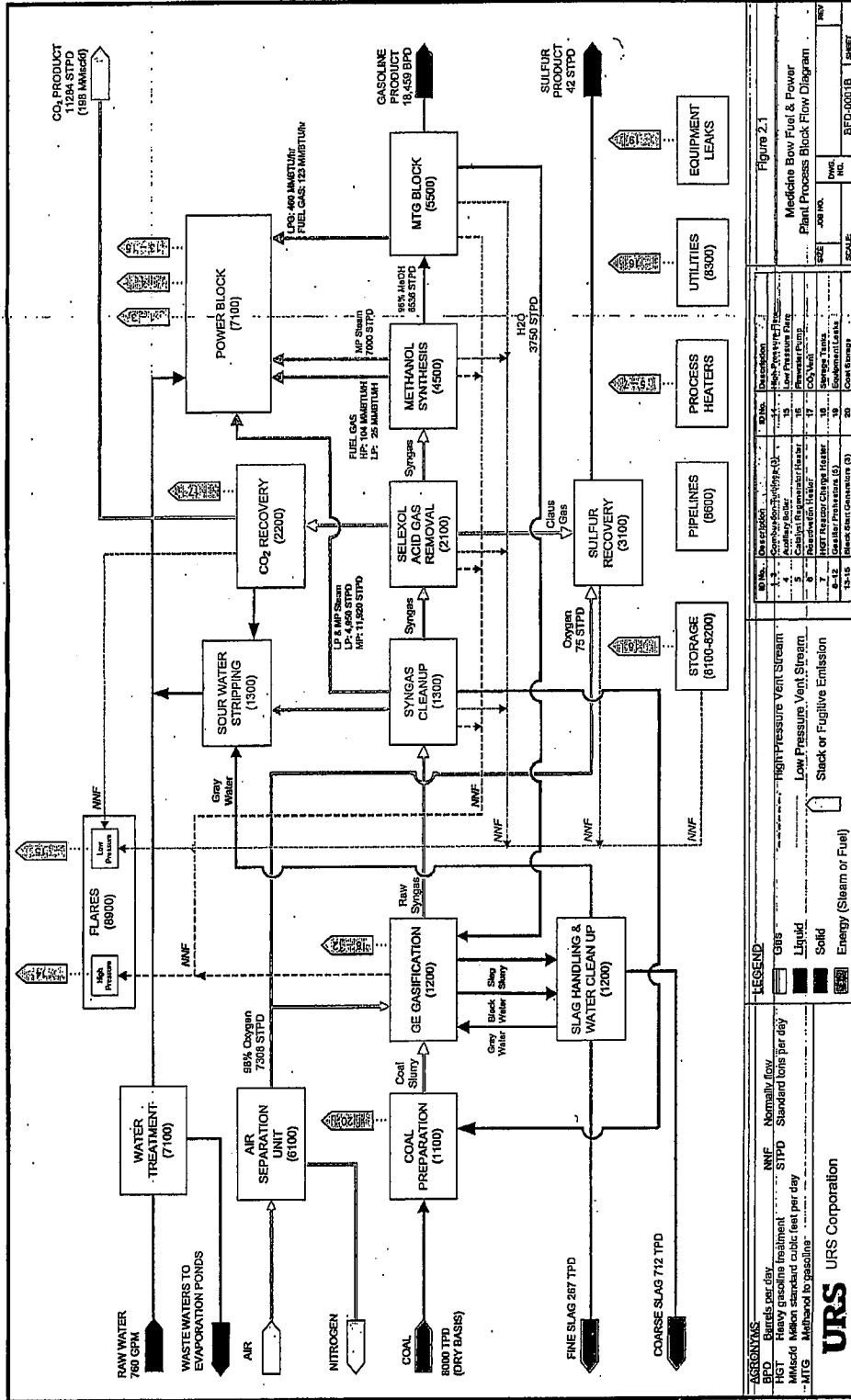

NO.	DESCRIPTION	UNIT	SCALE
1	RAW WATER	760 GPM	RAW
2	WASTEWATERS TO EVAPORATION PONDS		WASTE
3	AIR		RAW
4	NITROGEN		RAW
5	COAL	8000 TPD (DRY BASIS)	RAW
6	COAL SLURRY		RAW
7	RAW SYNGAS		RAW
8	CLEANED SYNGAS		RAW
9	CO2 PRODUCT	11294 STPD	RAW
10	FLARE GAS		RAW
11	SOUL WATER		RAW
12	SELEXTOL ACID GAS		RAW
13	METHANOL		RAW
14	GASOLINE PRODUCT	18,659 BPD	RAW
15	SULFUR PRODUCT	42 STPD	RAW
16	FINES SLAG	267 TPD	RAW
17	COARSE SLAG	712 TPD	RAW
18	CO2 RECOVERY		RAW
19	SELEXTOL		RAW
20	METHANOL SYNTHESIS		RAW
21	MTG BLOCK		RAW
22	POWER BLOCK		RAW
23	SULFUR RECOVERY		RAW
24	SYNGAS CLEANUP		RAW
25	SOUL WATER STRIPPING		RAW
26	FLARES		RAW
27	CO2 RECOVERY		RAW
28	SELEXTOL		RAW
29	METHANOL SYNTHESIS		RAW
30	MTG BLOCK		RAW
31	POWER BLOCK		RAW
32	SULFUR RECOVERY		RAW
33	SYNGAS CLEANUP		RAW
34	SOUL WATER STRIPPING		RAW
35	FLARES		RAW
36	CO2 RECOVERY		RAW
37	SELEXTOL		RAW
38	METHANOL SYNTHESIS		RAW
39	MTG BLOCK		RAW
40	POWER BLOCK		RAW
41	SULFUR RECOVERY		RAW
42	SYNGAS CLEANUP		RAW
43	SOUL WATER STRIPPING		RAW
44	FLARES		RAW
45	CO2 RECOVERY		RAW
46	SELEXTOL		RAW
47	METHANOL SYNTHESIS		RAW
48	MTG BLOCK		RAW
49	POWER BLOCK		RAW
50	SULFUR RECOVERY		RAW
51	SYNGAS CLEANUP		RAW
52	SOUL WATER STRIPPING		RAW
53	FLARES		RAW
54	CO2 RECOVERY		RAW
55	SELEXTOL		RAW
56	METHANOL SYNTHESIS		RAW
57	MTG BLOCK		RAW
58	POWER BLOCK		RAW
59	SULFUR RECOVERY		RAW
60	SYNGAS CLEANUP		RAW
61	SOUL WATER STRIPPING		RAW
62	FLARES		RAW
63	CO2 RECOVERY		RAW
64	SELEXTOL		RAW
65	METHANOL SYNTHESIS		RAW
66	MTG BLOCK		RAW
67	POWER BLOCK		RAW
68	SULFUR RECOVERY		RAW
69	SYNGAS CLEANUP		RAW
70	SOUL WATER STRIPPING		RAW
71	FLARES		RAW
72	CO2 RECOVERY		RAW
73	SELEXTOL		RAW
74	METHANOL SYNTHESIS		RAW
75	MTG BLOCK		RAW
76	POWER BLOCK		RAW
77	SULFUR RECOVERY		RAW
78	SYNGAS CLEANUP		RAW
79	SOUL WATER STRIPPING		RAW
80	FLARES		RAW
81	CO2 RECOVERY		RAW
82	SELEXTOL		RAW
83	METHANOL SYNTHESIS		RAW
84	MTG BLOCK		RAW
85	POWER BLOCK		RAW
86	SULFUR RECOVERY		RAW
87	SYNGAS CLEANUP		RAW
88	SOUL WATER STRIPPING		RAW
89	FLARES		RAW
90	CO2 RECOVERY		RAW
91	SELEXTOL		RAW
92	METHANOL SYNTHESIS		RAW
93	MTG BLOCK		RAW
94	POWER BLOCK		RAW
95	SULFUR RECOVERY		RAW
96	SYNGAS CLEANUP		RAW
97	SOUL WATER STRIPPING		RAW
98	FLARES		RAW
99	CO2 RECOVERY		RAW
100	SELEXTOL		RAW
101	METHANOL SYNTHESIS		RAW
102	MTG BLOCK		RAW
103	POWER BLOCK		RAW
104	SULFUR RECOVERY		RAW
105	SYNGAS CLEANUP		RAW
106	SOUL WATER STRIPPING		RAW
107	FLARES		RAW
108	CO2 RECOVERY		RAW
109	SELEXTOL		RAW
110	METHANOL SYNTHESIS		RAW
111	MTG BLOCK		RAW
112	POWER BLOCK		RAW
113	SULFUR RECOVERY		RAW
114	SYNGAS CLEANUP		RAW
115	SOUL WATER STRIPPING		RAW
116	FLARES		RAW
117	CO2 RECOVERY		RAW
118	SELEXTOL		RAW
119	METHANOL SYNTHESIS		RAW
120	MTG BLOCK		RAW
121	POWER BLOCK		RAW
122	SULFUR RECOVERY		RAW
123	SYNGAS CLEANUP		RAW
124	SOUL WATER STRIPPING		RAW
125	FLARES		RAW
126	CO2 RECOVERY		RAW
127	SELEXTOL		RAW
128	METHANOL SYNTHESIS		RAW
129	MTG BLOCK		RAW
130	POWER BLOCK		RAW
131	SULFUR RECOVERY		RAW
132	SYNGAS CLEANUP		RAW
133	SOUL WATER STRIPPING		RAW
134	FLARES		RAW
135	CO2 RECOVERY		RAW
136	SELEXTOL		RAW
137	METHANOL SYNTHESIS		RAW
138	MTG BLOCK		RAW
139	POWER BLOCK		RAW
140	SULFUR RECOVERY		RAW
141	SYNGAS CLEANUP		RAW
142	SOUL WATER STRIPPING		RAW
143	FLARES		RAW
144	CO2 RECOVERY		RAW
145	SELEXTOL		RAW
146	METHANOL SYNTHESIS		RAW
147	MTG BLOCK		RAW
148	POWER BLOCK		RAW
149	SULFUR RECOVERY		RAW
150	SYNGAS CLEANUP		RAW
151	SOUL WATER STRIPPING		RAW
152	FLARES		RAW
153	CO2 RECOVERY		RAW
154	SELEXTOL		RAW
155	METHANOL SYNTHESIS		RAW
156	MTG BLOCK		RAW
157	POWER BLOCK		RAW
158	SULFUR RECOVERY		RAW
159	SYNGAS CLEANUP		RAW
160	SOUL WATER STRIPPING		RAW
161	FLARES		RAW
162	CO2 RECOVERY		RAW
163	SELEXTOL		RAW
164	METHANOL SYNTHESIS		RAW
165	MTG BLOCK		RAW
166	POWER BLOCK		RAW
167	SULFUR RECOVERY		RAW
168	SYNGAS CLEANUP		RAW
169	SOUL WATER STRIPPING		RAW
170	FLARES		RAW
171	CO2 RECOVERY		RAW
172	SELEXTOL		RAW
173	METHANOL SYNTHESIS		RAW
174	MTG BLOCK		RAW
175	POWER BLOCK		RAW
176	SULFUR RECOVERY		RAW
177	SYNGAS CLEANUP		RAW
178	SOUL WATER STRIPPING		RAW
179	FLARES		RAW
180	CO2 RECOVERY		RAW
181	SELEXTOL		RAW
182	METHANOL SYNTHESIS		RAW
183	MTG BLOCK		RAW
184	POWER BLOCK		RAW
185	SULFUR RECOVERY		RAW
186	SYNGAS CLEANUP		RAW
187	SOUL WATER STRIPPING		RAW
188	FLARES		RAW
189	CO2 RECOVERY		RAW
190	SELEXTOL		RAW
191	METHANOL SYNTHESIS		RAW
192	MTG BLOCK		RAW
193	POWER BLOCK		RAW
194	SULFUR RECOVERY		RAW
195	SYNGAS CLEANUP		RAW
196	SOUL WATER STRIPPING		RAW
197	FLARES		RAW
198	CO2 RECOVERY		RAW
199	SELEXTOL		RAW
200	METHANOL SYNTHESIS		RAW
201	MTG BLOCK		RAW
202	POWER BLOCK		RAW
203	SULFUR RECOVERY		RAW
204	SYNGAS CLEANUP		RAW
205	SOUL WATER STRIPPING		RAW
206	FLARES		RAW
207	CO2 RECOVERY		RAW
208	SELEXTOL		RAW
209	METHANOL SYNTHESIS		RAW
210	MTG BLOCK		RAW
211	POWER BLOCK		RAW
212	SULFUR RECOVERY		RAW
213	SYNGAS CLEANUP		RAW
214	SOUL WATER STRIPPING		RAW
215	FLARES		RAW
216	CO2 RECOVERY		RAW
217	SELEXTOL		RAW
218	METHANOL SYNTHESIS		RAW
219	MTG BLOCK		RAW
220	POWER BLOCK		RAW
221	SULFUR RECOVERY		RAW
222	SYNGAS CLEANUP		RAW
223	SOUL WATER STRIPPING		RAW
224	FLARES		RAW
225	CO2 RECOVERY		RAW
226	SELEXTOL		RAW
227	METHANOL SYNTHESIS		RAW
228	MTG BLOCK		RAW
229	POWER BLOCK		RAW
230	SULFUR RECOVERY		RAW
231	SYNGAS CLEANUP		RAW
232	SOUL WATER STRIPPING		RAW
233	FLARES		RAW
234	CO2 RECOVERY		RAW
235	SELEXTOL		RAW
236	METHANOL SYNTHESIS		RAW
237	MTG BLOCK		RAW
238	POWER BLOCK		RAW
239	SULFUR RECOVERY		RAW
240	SYNGAS CLEANUP		RAW
241	SOUL WATER STRIPPING		RAW
242	FLARES		RAW
243	CO2 RECOVERY		RAW
244	SELEXTOL		RAW
245	METHANOL SYNTHESIS		RAW
246	MTG BLOCK		RAW
247	POWER BLOCK		RAW
248	SULFUR RECOVERY		RAW
249	SYNGAS CLEANUP		RAW
250	SOUL WATER STRIPPING		RAW
251	FLARES		RAW
252	CO2 RECOVERY		RAW
253	SELEXTOL		RAW
254	METHANOL SYNTHESIS		RAW
255	MTG BLOCK		RAW
256	POWER BLOCK		RAW
257	SULFUR RECOVERY		RAW
258	SYNGAS CLEANUP		RAW
259	SOUL WATER STRIPPING		RAW
260	FLARES		RAW
261	CO2 RECOVERY		RAW
262	SELEXTOL		RAW
263	METHANOL SYNTHESIS		RAW
264	MTG BLOCK		RAW
265	POWER BLOCK		RAW
266	SULFUR RECOVERY		RAW
267	SYNGAS CLEANUP		RAW
268	SOUL WATER STRIPPING		RAW
269	FLARES		RAW
270	CO2 RECOVERY		RAW
271	SELEXTOL		RAW
272	METHANOL SYNTHESIS		RAW
273	MTG BLOCK		RAW
274	POWER BLOCK		RAW
275	SULFUR RECOVERY		RAW
276	SYNGAS CLEANUP		RAW
277	SOUL WATER STRIPPING		RAW
278	FLARES		RAW
279	CO2 RECOVERY		RAW
280	SELEXTOL		RAW
281	METHANOL SYNTHESIS		RAW
282	MTG BLOCK		RAW
283	POWER BLOCK		RAW
284	SULFUR RECOVERY		RAW
285	SYNGAS CLEANUP		RAW
286	SOUL WATER STRIPPING		RAW
287	FLARES		RAW
288	CO2 RECOVERY		RAW
289	SELEXTOL		RAW
290	METHANOL SYNTHESIS		RAW
291	MTG BLOCK		RAW
292	POWER BLOCK		RAW
293	SULFUR RECOVERY		RAW
294	SYNGAS CLEANUP		RAW
295	SOUL WATER STRIPPING		RAW
296	FLARES		RAW
297	CO2 RECOVERY		RAW
298	SELEXTOL		RAW
299	METHANOL SYNTHESIS		RAW
300	MTG BLOCK		RAW
301</			

Saddleback Hills Mine

The mine will produce approximately 3.2 MMTPY of coal using underground continuous and longwall miners. Longwall mining machines consist of multiple coal shearers mounted on a series of self-advancing hydraulic ceiling supports. The mined coal will exit the mine via the East Portal. Coal will be conveyed and stored in a 300,000 ton live storage area before being conveyed to the plant. An additional 300,000 ton emergency coal stockpile will be constructed. The emergency coal stockpile will be considered dead storage and will not be used unless the coal supply for the live storage is interrupted.

Medicine Bow IGL Plant

- Coal Preparation

Raw feed coal is routed via an enclosed conveyor to the coal crusher. The crushed coal is screened to a maximum size of 1 inch, with oversized recycled back to the crusher. The crushed and screened coal is conveyed and stored in bins and is gravity flowed to the coal-grinding mill. In the grinding mill the coal is crushed further with water and an additive to create slurry, which will be pumped into the gasifiers under high pressure.

- Gasification

The plant will utilize five (5) gasifier trains. Each gasifier train will be sized to handle one-fourth of the plants total capacity. In normal operation, four gasifiers trains will be in operation with the fifth in hot standby. The gasifiers are fueled by a coal/water slurry, calcium carbonate, and 98 percent pure oxygen from the air separation units.

- Syngas Conditioning

Raw syngas leaves the gasifiers and is mixed with process condensate in the process line to prevent the buildup of solids and facilitate their removal in the syngas scrubber. From the syngas scrubber the syngas is sent to a low-temperature gas cleanup (LTGC) unit. The syngas is cooled in a series of heat exchangers, and the partially condensed syngas is separated. After separation, the syngas is heated and split into two streams. The syngas either enters a water gas phase shift reactor which converts carbon monoxide (CO) and H₂O to CO₂ and H₂ and hydrolyzes carbonyl-sulfide (COS) or enters a reactor where COS is hydrolyzed to hydrogen sulfide (H₂S) and CO₂. The syngas is then routed to the SELEXOL[®] acid gas removal unit.

Condensate from the LTGC area flows to a stripper. The stripper removes almost all of the ammonia (NH₃), H₂S, and COS from the condensate, along with some dissolved H₂ and CO. The stripper overhead gas is blended with sour flash gas and gases from the flash separators before being sent to the SELEXOL[®] Unit.

- Acid Gas Removal

Syngas from the syngas conditioning area enters an activated carbon bed for mercury removal. The syngas is then mixed with recycled stripped gas and flows to the SELEXOL[®] Feed/Product exchanger to cool the gas. The gas flows through two successive absorbers; the first removes H₂S and the second absorber removes CO₂. In these absorbers the gases are converted to the liquid phase. Treated syngas is then sent to the Methanol Synthesis Unit.

The SELEXOL[®] solvent from the H₂S absorber is regenerated by stripping out less soluble gases, such as CO₂, H₂, and CO. The partially regenerated solvent then flows to an H₂S stripper where the liquid and gases are separated. An H₂S rich gas stream exits the unit and is sent to the sulfur recover unit (SRU), and the liquids are returned to the H₂S stripper.

- Methanol Synthesis

Treated syngas is compressed and preheated and sent to the Syngas Purification Vessel, which removes any remaining impurities. Gas from the Syngas Purification Vessel then enters the methanol reactors. Gas leaving the reactor is cooled and methanol and water condense out. The remaining gas is compressed and mixed with incoming syngas and recycled through the methanol reactors. Crude methanol is reduced in pressure to flash off dissolved gases, and sent to the power block as fuel. During normal operation, the crude methanol is sent to the methanol to gasoline (MTG) unit. However, if the MTG unit is offline the crude methanol is sent to intermediate storage.

- Methanol to Gasoline (MTG)

Crude methanol is partially dehydrated using an alumina catalyst to achieve an equilibrium mixture of methanol, dimethyl ether (DME), and water. The methanol and DME undergo a series of dehydration reactions in the MTG reactors forming light alkenes. The light alkenes then undergo chain growth by joining two or more alkenes together to give the final products. The MTG process also contains a heavy gasoline treatment (HGT) step to reduce durenene to suitable levels. Heavy gasoline is hydrotreated in a fixed-bed reactor, and the treated gasoline is combined with the light fraction to produce finished MTG gasoline.

- CO₂ Recovery and Production

A CO₂ rich gas stream exits the SELEXOL[®] unit and flows into the CO₂ recovery unit. The CO₂ is compressed in one of three parallel four-stage centrifugal compressor trains and dried in a drying unit installed upstream of the third stage compressor suction. Some of the CO₂ is refrigerated to provide liquid coolant to the Methanol Synthesis and SELEXOL[®] units, and the remaining CO₂ is compressed and sent to a pipeline customer.

- Sulfur Recovery and Production

Acid gas from the SELEXOL[®] unit enters the SRU which consists of a three stage Claus process. The acid gas is first washed with stripped sour water, and is injected into a reaction furnace, where it is partially combusted. The gases are then sent to reactors to produce elemental sulfur. Gases leaving the reactor are cooled to condense the elemental sulfur, which flows to a below-ground concrete pit. Gases containing unconverted sulfur compounds are passed through a hydrogenation reactor that reduces them to H₂S. This gas is recycled back to the SELEXOL[®] unit, or to a flare during an upset condition at the plant.

- Power Generation

The power block will consist of three GE 7EA gas turbines fueled by a mixture of fuel gas, LPG, syngas, and natural gas that will produce approximately 185 megawatts (MW) in simple cycle mode. A heat recovery system on the gas turbine exhaust will superheat medium, low, and high pressure steam. This superheated steam will then flow to a single, three-stage steam turbine, producing approximately 215 MW of additional power, for a total of 400 MW. During startup, power will be supplied by three 1.6 MW Black Start Generators. These generators will fire natural gas and will be operated until the power block can supply sufficient power for the plant.

- Air Separation Unit

Atmospheric air is compressed to approximately 100 pounds per square inch absolute (psia) using electric-driven compressors and fed to the air separation unit where oxygen is separated cryogenically. Following separation, the oxygen is pumped to high pressure as a liquid and vaporized against a stream of condensing high pressure air. Most of the oxygen is fed to the gasifiers with a small portion routed to the SRU.

ESTIMATED EMISSIONS:

Saddleback Hills Mine

As part of the IGL plant, MBFP will operate an underground coal mine known as the Saddleback Hills Mine. During the underground mine's development phase, approximately 2.1 million tons of coal will need to be mined over a 3-year period. The development phase constructs the underground infrastructure required to support the longwall mining system which will commence operations at approximately the time when the plant achieves full capacity. During the development of the mine, coal will be conveyed from the South Portal where it will be stored in a stockpile. It is anticipated that this production will be placed in the long-term storage stockpile. If there is excess production in the development phase, coal will be loaded into trucks at the South Portal and hauled to the Seminoe II train loadout facility near Hanna, Wyoming. The following activities will also occur at the East Portal of the underground mine: construction of the East Portal entry areas consisting of a reinforced concrete retaining wall, installation of enclosed conveyors from the portal face to the coal storage facilities, construction of the coal storage facilities, construction of an enclosed overland conveyor from the coal storage facilities to the plant, and construction of the Mine's office, maintenance shop, and warehouse facilities. Particulate emissions associated with the development phase are shown in the following table:

Year	PM ₁₀ tpy
1	26.8
2	109.3
3	71.6

Medicine Bow IGL Plant

The following tables show the emission units and fugitive sources for the Medicine Bow IGL Plant. Emissions are based on manufacture information, emission estimation programs (i.e. EPA Tanks 4.9), and approved equations for emission estimation.

Description	ID	Size	Use
Normal Operation Equipment			
Combustion Turbine 1	CT-1	66 MW	Electrical and steam generation
Combustion Turbine 2	CT-2	66 MW	Electrical and steam generation
Combustion Turbine 3	CT-3	66 MW	Electrical and steam generation
Auxiliary Boiler	AB	66 MMBtu/hr	Steam generation (normal service is standby at 25% load)
Catalyst Regenerator	B-1	21.53 MMBtu/hr	Catalyst regeneration (firing rate at 3.58 MMBtu/hr in standby mode which is approximately 7800 hours/year)
Reactivation Heater	B-2	12.45 MMBtu/hr	Reactivation heating
HGT Reactor Charge Heater	B-3	2.22 MMBtu/hr	Reactor charge heating
HP Flare (pilot only)	FL-1	0.82 MMBtu/hr	Plant safety
LP Flare (pilot only)	FL-2	0.20 MMBtu/hr	Plant safety
Equipment Leaks	EL	--	--
Storage Tanks	Tanks	Various	Methanol and gasoline storage
Coal Storage	CS		Coal feedstock storage
Startup/Shutdown/Malfunction Equipment			
Gasifier Preheater 1	GP-1	21 MMBtu/hr	Gasifier refractory preheating
Gasifier Preheater 2	GP-2	21 MMBtu/hr	Gasifier refractory preheating
Gasifier Preheater 3	GP-3	21 MMBtu/hr	Gasifier refractory preheating
Gasifier Preheater 4	GP-4	21 MMBtu/hr	Gasifier refractory preheating
Gasifier Preheater 5	GP-5	21 MMBtu/hr	Gasifier refractory preheating
Black Start Generator 1	Gen-1	2889 hp	Electrical Generation
Black Start Generator 2	Gen-2	2889 hp	Electrical Generation
Black Start Generator 3	Gen-3	2889 hp	Electrical Generation
Firewater Pump Engine	FW-Pump	575 hp	Supplies emergency firewater
CO ₂ Vent Stack	CO ₂ VS	--	For malfunctions

ID	Description	NO _x	CO	VOC	SO ₂	PM/PM ₁₀
CT-1	Combustion Turbine	50.6 ¹	46.2	6.6	10.8	43.8
CT-2	Combustion Turbine	50.6 ¹	46.2	6.6	10.8	43.8
CT-3	Combustion Turbine	50.6 ¹	46.2	6.6	10.8	43.8
AB	Auxiliary Boiler ²	14.2	23.8	1.6	0.2	2.2
B-1	Catalyst Regenerator ²	4.6	7.8	0.5	0.1	0.7
B-2	Reactivation Heater	2.7	4.5	0.3	0.1	0.4
B-3	HGT Reactor Charge Heater	0.5	0.8	0.1	0.1	0.1
Tanks	Storage	--	--	102.6	--	--
EL	Equipment Leaks	--	--	59.6	--	--
CS	Coal Storage	--	--	--	--	60.2
FW-Pump	Firewater Pump Engine ³	1.5	0.1	0.3	--	0.1
FL-1	HP Flare	0.5	1.0	3.0	--	--
FL-2	LP Flare	0.1	0.3	0.7	--	--
Totals		175.9	176.9	188.5	32.9	195.1

¹ Revised based on BACT analysis

² Emissions from these units were estimated based on full load and 8760 hours per year.

³ Emissions are based on 500 hours of operation per year.

Pollutant	Facility Wide Potential ¹	Largest Emission Source
Benzene	8.5	Equipment Leaks
Formaldehyde	0.7	Turbines
Hexane	1.3	Auxiliary Boiler
Methanol	10.3	Equipment Leaks
Toluene	1.8	Turbines
Other Haps	2.2	--
Total HAPs	24.8	--

¹ Rounded to the nearest tenth of a ton.

The following table shows emissions from the facility based on a cold startup during the year. Emissions include equipment used primarily during startup and reflect emissions prior to the activation of control equipment (i.e. SCR for NO_x control).

ID	Description	NO _x	CO	VOC	SO ₂	PM/PM ₁₀
CT-1	Combustion Turbine	50.8 ¹	46.6	6.6	10.9	43.8
CT-2	Combustion Turbine	50.8 ¹	46.6	6.6	10.9	43.8
CT-3	Combustion Turbine	50.8 ¹	46.6	6.6	10.9	43.8
Gen-1	Black Start Generator 1	0.8	1.9	0.3	--	--
Gen-2	Black Start Generator 2	0.8	1.9	0.3	--	--
Gen-3	Black Start Generator 3	0.8	1.9	0.3	--	--
AB	Auxiliary Boiler ²	14.2	23.8	1.6	0.2	2.2
B-1	Catalyst Regenerator ²	4.6	7.8	0.5	0.1	0.7
B-2	Reactivation Heater	2.7	4.5	0.3	0.1	0.4
B-3	HGT Reactor Charge Heater	0.5	0.8	0.1	0.1	0.1
GP-1	Gasifier Preheater 1	0.3	0.4	0.1	--	0.1
GP-2	Gasifier Preheater 2	0.3	0.4	0.1	--	0.1
GP-3	Gasifier Preheater 3	0.3	0.4	0.1	--	0.1
GP-4	Gasifier Preheater 4	0.3	0.4	0.1	--	0.1
GP-5	Gasifier Preheater 5	0.3	0.4	0.1	--	0.1
Tanks	Storage	--	--	102.6	--	--
EL	Equipment Leaks	--	--	59.6	--	--
CS	Coal Storage	--	--	--	--	60.2
FW-Pump	Firewater Pump Engine ³	1.5	0.1	0.3	--	0.1
CO ₂ VS	CO ₂ Vent Stack	--	314.9	0.8	--	--
FL-1	HP Flare	10.3	81.9	3.1	187.7	--
FL-2	LP Flare	0.2	0.4	0.8	36.0	--
Totals		190.3	581.7	190.9	256.9	195.6

¹ Revised based on BACT analysis

² Emissions from these units were estimated based on full load and 8760 hours per year.

³ Emissions are based on 500 hours of operation per year.

ID	Description	NO _x	CO	VOC	SO ₂	PM/PM ₁₀
CT-1	Combustion Turbine	18.7	18.9	1.5	2.7	10.0
CT-2	Combustion Turbine	18.7	18.9	1.5	2.7	10.0
CT-3	Combustion Turbine	18.7	18.9	1.5	2.7	10.0
Gen-1	Black Start Generator 1	6.4	15.5	5.7	<0.1	<0.1
Gen-2	Black Start Generator 2	6.4	15.5	5.7	<0.1	<0.1
Gen-3	Black Start Generator 3	6.4	15.5	5.7	<0.1	<0.1
AB	Auxiliary Boiler	3.2	5.4	0.4	<0.1	0.5
B-1	Catalyst Regenerator	1.1	1.8	0.1	<0.1	0.2
B-2	Reactivation Heater	0.6	1.0	0.1	<0.1	0.1
B-3	HGT Reactor Charge Heater	0.1	0.2	<0.1	<0.1	<0.1
GP-1	Gasifier Preheater 1	<0.1	1.7	<0.1	<0.1	0.2
GP-2	Gasifier Preheater 2	<0.1	1.7	<0.1	<0.1	0.2
GP-3	Gasifier Preheater 3	<0.1	1.7	<0.1	<0.1	0.2
GP-4	Gasifier Preheater 4	<0.1	1.7	<0.1	<0.1	0.2
GP-5	Gasifier Preheater 5	<0.1	1.7	<0.1	<0.1	0.2
Tanks	Storage	--	--	23.4	--	--
EL	Equipment Leaks	--	--	13.6	--	--
CS	Coal Storage	--	--	--	--	13.7
FW-Pump	Firewater Pump Engine	6.0	0.4	1.4	<0.1	0.1
CO ₂ VS	CO ₂ Vent Stack	--	3,358.8	0.2	--	--
FL-1	HP Flare	2.3	3,249.2	0.7	7,508.1	--
FL-2	LP Flare	<0.1	19.4	0.2	3,601.2	--
Totals		88.6	6,747.9	61.7	11,117.4	45.6

CHAPTER 6, SECTION 4 APPLICABILITY:

The Medicine Bow IGL Plant is subject to Prevention of Significant Deterioration (PSD) applicability review under Chapter 6, Section 4 of the Wyoming Air Quality Standards and Regulations (WAQSR) because it is classified as a “major stationary source” as emissions of a criteria pollutant are greater than 100 tpy. Additionally, the Saddleback Hills Mine and Medicine Bow IGL Plant are considered one facility as the mine is a support operation for the plant. The Medicine Bow IGL Plant is subject to a 100 tpy threshold as it is a named source category (fuel conversion plants) under Chapter 6, Section 4 of the WAQSR. Potential emission rates from the Medicine Bow IGL Plant along with the PSD significant levels are shown in the following table.

	NO _x	CO	VOC	SO ₂	PM/PM ₁₀	Lead	Fluorides	H ₂ S
Potential Emissions	175.9	176.9	188.5	32.9	195.1	0.58	0.001	0.009
PSD Significant Emission Levels	40	100	40	40	25/15	0.6	3	10
PSD Review Required	YES	YES	YES	NO	YES	NO	NO	NO

The Medicine Bow IGL Plant is subject to a Prevention of Significant Deterioration (PSD) review consisting of the following:

- A Best Available Control Technology (BACT) analysis is required for all regulated pollutant emitted in significant amounts.
- An ambient air quality impact determination is required for all regulated pollutants emitted in significant amounts and any other pollutants required by the Administrator.
- An increment consumption analysis is required for regulated pollutants based on allowable emission rates as well as increment consuming emissions from other sources in the region. The total deterioration determined from this analysis must comply with the allowable increments established for PM₁₀ and NO_x for the classification of the area (i.e. Class I or Class II) in which the increment consumption is predicted.
- An analysis is required to assess the impairment to visibility, soils, and vegetation resulting from the facility and general commercial, residential, industrial, and other growth associated with the facility.

CHAPTER 6, SECTION 4 – PSD TOP DOWN BEST AVAILABLE CONTROL TECHNOLOGY (BACT):

Per the requirements of Chapter 6, Section 4 of the WAQSR, MBFP conducted a top-down BACT analysis for control of pollutants (NO_x, CO, VOCs and PM₁₀) which are greater than significant increase emission rates.

• NO_x Emissions

- **Turbines**

Control Options

MBFP identified the following technologies for the control of NO_x emissions from the proposed turbines at the Medicine Bow IGL Plant:

- Diluent Injection
- Dry Low NO_x Burners
- Low NO_x Burners
- Flue Gas Recirculation (FGR)
- EM_x
- Selective Non-Catalytic Reduction (SNCR)
- Selective Catalytic Reduction (SCR)

Diluent injection involves the use of a diluent, such as water, steam, or nitrogen added to the fuel gas mixture to reduce the combustion temperature and formation of thermal NO_x.

Dry Low NO_x burners utilizes a burner design that controls the stoichiometry and temperature of combustion by regulating the distribution and pre-mixing of fuel and air, which minimizes localized fuel-rich pockets that produce elevation combustion temperatures and higher NO_x emissions.

Low NO_x burners are designed to control fuel and air mixing at each burner in order to create larger and more branched flames. This reduces peak flame temperature and results in less NO_x formation.

Flue gas recirculation reduces NO_x emissions by recirculating a portion of the flue gas into the main combustion chamber. This process reduces the peak flame temperature and lowers the percentage of oxygen in the combustion air/fuel gas mixture reducing thermal NO_x formation.

EM_x is a control technology that utilizes a single catalyst for the reduction of NO_x, CO, and VOCs and does not require a reagent such as ammonia. The EM_x catalyst functions by oxidizing NO to NO₂. The NO₂ is then absorbed on the surface of the catalyst through the use of a potassium carbonate coating. The potassium carbonate coating reacts with NO₂ to form potassium nitrites and nitrates.

Selective non-catalytic reduction (SNCR) reduces NO_x emissions by injection of ammonia or urea into the turbine combustor. SNCR is similar to SCR in that both systems use ammonia to react with nitrogen; however, SNCR operates at higher temperatures than SCR and does not use catalyst. The effective temperature range for SNCR is 1600 to 2200 °F.

Selective Catalytic Reduction (SCR) is a post-combustion NO_x control technology that can be used on combustion turbines. SCR reduces NO_x emissions by injecting ammonia into the exhaust gas stream upstream of a catalyst. The ammonia reacts with NO_x on the catalyst to form molecular nitrogen and water vapor. For the SCR system to operate properly, the exhaust gas must be within a temperature range of 450 to 850 °F.

Eliminate Technically Infeasible Options

MBFP eliminated dry low NO_x burners as a viable control option as the vendor indicated that dry low NO_x burners are not feasible for fuels that contain less than 85% by volume methane or that contain substantial amounts of hydrogen. The fuel gas mixture utilized in the turbines contains 61.4% methane and 15.3% hydrogen.

Flue gas recirculation was eliminated as being technically infeasible as this control strategy has not been developed for use in turbines.

EM_x technology was eliminated as being technically infeasible as this technology has not been applied to large-scale turbines utilizing a fuel gas mixture with syngas.

SNCR technology was eliminated from consideration as it has never been applied to natural gas combined cycle or syngas/fuel gas mixture units because no locations exist in the heat recovery steam generator with the optimal temperature and residence time that are necessary to accommodate this technology.

Rank Remaining Technologies

The following NO_x control technologies are ranked according to the level of emission rates achievable (control effectiveness): SCR, Low NO_x burners, diluent injection.

Evaluate Remaining Technologies

MBFP selected SCR for NO_x control with an emission rate of 6 ppm_{vd} at 15% oxygen. Since MBFP has selected the top control option an evaluation was not conducted for the other NO_x controls. However, the Division requested that MBFP further evaluate the cost of achieving a lower NO_x emission rate from the turbines utilizing SCR. MBFP examined the cost to go down to an emission rate of 4 ppm_{vd} at 15% oxygen, but didn't address lower levels due to technical issues. These issues include pressure loss in the combustion turbine and the variability in plant-generated fuels can prevent system optimization from the combustion turbine and SCR system.

The following table shows the average cost effectiveness for controlling NO_x emissions with the use of SCR.

Table VII Medicine Bow Fuel & Power, LLC Turbine Average Cost Effectiveness NO _x				
	Emission Rate	Annual Cost	Cost Effectiveness	Emission Reduction (tpy)
Case 1	6 ppm _v @ 15% O ₂	\$541,200	\$2,253/ton	240.2
Case 2	4 ppm _v @ 15% O ₂	\$603,285	\$2,272/ton	265.5

The average cost effectiveness is the total annualized cost for the option, including capital cost and annual operating and maintenance costs, divided by the emission reduction. The Division considers the average cost effectiveness to be reasonable for both options.

The incremental cost effectiveness for going from Case 1 (6 ppm_v) to Case 2 (4 ppm_v) is calculated in the following table. The incremental emission reduction and incremental increase in total annualized cost is the difference in these values from the previous table. The incremental cost effectiveness is the incremental increase in total annualized cost divided by the incremental emission reduction.

Table VIII Medicine Bow Fuel & Power, LLC Turbine NO _x Incremental Cost			
Options Compared	Incremental Emissions Reduction (tpy)	Incremental Increase in Total Annualized Cost (\$)	Incremental Cost Effectiveness (\$/ton)
Case 1 and Case 2	25.3	62,085	2,454

In this case, the average cost effectiveness for both options is within the range the Division has considered acceptable. In addition, the Division considers the incremental cost effectiveness of \$2,454/ton of NO_x reasonable for an additional 25.3 tpy emission reduction.

The Division reviewed the EPA's RACT/BACT/LEAR Clearinghouse (RBLC) and looked at permits issued for IGCC plants issued by state permitting agencies. The most recent permit found was issued to Christian County Generation, LLC for an IGCC plant at the Taylorville Energy Center on June 5, 2007. This permit required NO_x control of 5 ppm_{vd} at 15% oxygen on a 24-hour block average.

Select NO_x BACT (Conclusion)

Based on the cost effectiveness and incremental cost of going from 6 ppm_v to 4 ppm_v, the Division considers SCR with emission limits of 4 ppm_v at 15% O₂ and 11.6 lb/hr based on 30-day rolling averages as representing BACT for NO_x for the turbines.

o **Auxiliary Boiler and Process Heaters**

Control Options

MBFP identified the following technologies for the control of NO_x emissions from the proposed auxiliary boiler and process heaters (Catalyst Regenerator, Reactivation Heater, and HGT Reactor Charge Heater) at the Medicine Bow IGL Plant:

- Low NO_x Burners
- Low NO_x Burners with Flue Gas Recirculation
- Non-Selective Catalytic Reduction (NSCR)
- EM_x
- Selective Non-Catalytic Reduction (SNCR)
- Selective Catalytic Reduction (SCR)

The above control options were described in the previous BACT discussion (control options) for the turbines except for NSCR, and will not be further described here. NSCR is a post combustion technology that utilizes a catalyst to reduce NO_x emissions under fuel-rich conditions.

Eliminate Technically Infeasible Options

LNB with FGR was considered to be technically infeasible as this combination of control technology has not been installed on boilers/heaters less than 100 MMBtu/hr and with the type of fuel gas utilized at this facility.

NSCR was eliminated as this technology has never been applied to boilers/heater, and this technology is commonly utilized on rich burn engines.

EM_x was eliminated from consideration as this technology has had limited use on boilers/heaters and those installations have not demonstrated the ability to reduce emissions as proposed.

SNCR technology was eliminated from consideration as the exhaust temperatures from the auxiliary boiler and process heaters range from 700 to 900°F, which is outside the temperature window needed for SNCR.

Rank Remaining Technologies

The remaining NO_x control technologies for the auxiliary boiler and process heaters in order of control effectiveness are as follows: SCR and LNB.

Evaluate Remaining Technologies

MBFL selected LNB as representing BACT for the auxiliary boiler and process heaters. They did not evaluate SCR for the auxiliary boiler and process heaters based on the size of these units (≤ 66 MMBtu/hr) and their operation. The auxiliary boiler will operate in a stand-by mode during normal operation which is approximately 25 percent load or less. This unit is designed to prevent freeze ups at the plant in the event of shutdown of the facility. The Catalyst Regenerator and Reactivation Heater also operate in low loads during normal operation. The Catalyst Regenerator and Reactivation Heater units fire at capacity, on an as needed basis, when a catalyst in the methanol synthesis or methanol to gasoline processes needs to be reactivated. The Division concurs with MBFP that based on the size and operation of these units that SCR did not need to be further addressed for these units. MBFP has proposed a NO_x emission rate of 0.05 lb/MMBtu for the auxiliary boiler and process heaters (Catalyst Regenerator, Reactivation Heater, and HGT Reactor Charge Heater).

Select NO_x BACT (Conclusion)

Based on the size and operation of these units, the Division considers the use of Low NO_x burners with an emission rate of 0.05 lb/MMBtu for the auxiliary boiler, catalyst regenerator, reactivation heater, and HGT reactor charge heater as being representative of BACT.

o Startup Units (Gasifier Preheaters and Black Start Generators) and Emergency Unit (Fire Water Pump Engine)

The units addressed in this section are utilized during startup of the Medicine Bow IGL Plant. The five (5) proposed gasifier preheaters are proposed at 21 MMBtu/hr and each gasifier preheater is expected to operate for no more than 500 hours per year (2,500 hours total for 5 preheaters). MBFP has proposed a NO_x emission rate of 0.05 lb/MMBtu for the gasifier preheaters with the use of Low NO_x burners. Based on the size and operation of these units, the Division considers the use of Low NO_x burners with a NO_x emission rate of 0.05 lb/MMBtu as being representative of BACT.

The three (3) Black Start Generators are 2,889 horsepower in size and each generator is anticipated to operate no more than 250 hours per year. MBFP has proposed a NO_x emission rate of 1.0 g/hp-hr for these units. Based on the limited operating hours for these units the Division considers 1.0 g/hp-hr NO_x to be representative of BACT.

MBFP has proposed to comply with the requirements of Subpart IIII of 40 CFR part 60 for the fire water pump engine. This engine will also be limited to 500 hours of operation per year. The Division considers compliance with Subpart IIII and limited operating hours to be representative of BACT for this unit.

• **CO Emissions**

◦ **Turbines**

Control Options

MBFP identified the following technologies for the control of CO emissions from the proposed turbines at the Medicine Bow IGL Plant:

Good Combustion Practices (proper operation)
EM_x
Oxidation Catalyst

EM_x is a control technology that utilizes a single catalyst for the reduction of NO_x, CO, and VOCs and does not require a reagent such as ammonia. The EM_x catalyst functions by oxidizing CO to CO₂.

An oxidation catalyst is a post combustion control technology that utilizes a catalyst to oxidize CO in CO₂.

Eliminate Technically Infeasible Options

EM_x technology was eliminated as being technically infeasible as this technology has not been applied to large-scale turbines utilizing a fuel gas mixture with syngas.

Rank Remaining Technologies

The remaining CO control technologies for the turbines in order of control effectiveness are an oxidation catalyst and good combustion practices.

Evaluate Remaining Technologies

MBFP selected an oxidation catalyst with an emission rate of 6 ppm_v as being representative of BACT for CO control from the turbines. Since MBFP has selected the top control option for CO, no further evaluation was conducted for good combustion practices.

Select CO BACT (Conclusion)

The Division considers an oxidation catalyst with emission limits of 6 ppm_v at 15% O₂ and 10.6 lb/hr based on 30-day rolling averages as representing BACT for CO for the turbines.

o **Auxiliary Boiler and Process Heaters**

Control Options

MBFP identified the following technologies for the control of CO emissions from the proposed auxiliary boiler and process heaters (Catalyst Regenerator, Reactivation Heater, and HGT Reactor Charge Heater) at the Medicine Bow IGL Plant:

Good Combustion Practices (proper operation)
EM_x
Oxidation Catalyst

EM_x is a control technology that utilizes a single catalyst for the reduction of NO_x, CO, and VOCs and does not require a reagent such as ammonia. The EM_x catalyst functions by oxidizing CO to CO₂.

An oxidation catalyst is a post combustion control technology that utilizes a catalyst to oxidize CO in CO₂.

Eliminate Technically Infeasible Options

An oxidation catalyst was eliminated as technically infeasible as this technology has not been applied to syngas process fired heaters.

EM_x was eliminated from consideration as this technology has had limited use on boilers/heaters and that those installations have not demonstrated the ability to reduce emissions as proposed.

Rank/Evaluate/Select BACT:

Based on the removal of the infeasible options the only remaining control option is good combustion practices. MBFP has proposed a CO emission rate of 0.08 lb/MMBtu. The Division agrees that a CO emission rate of 0.08 lb/MMBtu based on good combustion practices is considered representative of BACT for the auxiliary boiler and process heaters process heaters (Catalyst Regenerator, Reactivation Heater, and HGT Reactor Charge Heater).

o **Startup Units (Gasifier Preheaters and Black Start Generators) and Emergency Unit (Fire Water Pump Engine)**

The five (5) proposed gasifier preheaters are proposed at 21 MMBtu/hr and each gasifier preheater is expected to operate for no more than 500 hours per year (2,500 hours total for 5 preheaters). MBFP has proposed a CO emission rate of 0.08 lb/MMBtu for the gasifier preheaters based on good combustion practices. Based on the size and operation of these units, the Division considers the use of good combustion practices with a CO emission rate of 0.08 lb/MMBtu as being representative of BACT.

The three (3) Black Start Generators are 2,889 horsepower in size and each generator is anticipated to operate no more than 250 hours per year. MBFP has proposed a CO emission rate of 2.43 g/hp-hr for these units. Based on the limited operating hours for these units the Division considers 2.43 g/hp-hr CO to be representative of BACT.

MBFP has proposed to comply with the requirements of Subpart IIII of 40 CFR part 60 for the fire water pump engine. This engine will also be limited to 500 hours of operation per year. The Division considers compliance with Subpart IIII and limited operating hours to be representative of BACT for this unit.

• **VOC Emissions**

◦ **Turbines**

Control Options

MBFP identified the following technologies for the control of VOC emissions from the proposed turbines at the Medicine Bow IGL Plant:

Good Combustion Practices (proper operation)
EM_x
Oxidation Catalyst

EM_x is a control technology that utilizes a single catalyst for the reduction of NO_x, CO, and VOCs and does not require a reagent such as ammonia.

An oxidation catalyst is a post combustion control technology that utilizes a catalyst to oxidize VOC.

Eliminate Technically Infeasible Options

EM_x technology was eliminated as being technically infeasible as this technology has not been applied to large-scale turbines utilizing a fuel gas mixture with syngas.

Rank Remaining Technologies

The remaining VOC control technologies for the turbines in order of control effectiveness are an oxidation catalyst and good combustion practices.

Evaluate Remaining Technologies

MBFP selected an oxidation catalyst with an emission rate of 1.4 ppm_v as being representative of BACT for VOC control from the turbines. Since MBFP has selected the top control option for VOC, no further evaluation was conducted for good combustion practices.

Select VOC BACT (Conclusion)

The Division considers an oxidation catalyst with emission limits of 1.4 ppm_v at 15% O₂ and 1.5 lb/hr as representing BACT for VOC for the turbines.

o **Auxiliary Boiler and Process Heaters**

Control Options

MBFP identified the following technologies for the control of VOC emissions from the proposed auxiliary boiler and process heaters (Catalyst Regenerator, Reactivation Heater, and HGT Reactor Charge Heater) at the Medicine Bow IGL Plant:

Good Combustion Practices
EM_x
Oxidation Catalyst

EM_x is a control technology that utilizes a single catalyst for the reduction of NO_x, CO, and VOCs and does not require a reagent such as ammonia.

An oxidation catalyst is a post combustion control technology that utilizes a catalyst to oxidize VOC.

Eliminate Technically Infeasible Options

An oxidation catalyst was eliminated as technically infeasible as this technology has not been applied to syngas process fired heaters.

EM_x was eliminated from consideration as this technology has had limited use on boilers/heaters and that those installations have not demonstrated the ability to reduce emissions as proposed.

Rank/Evaluate/Select BACT:

Based on the removal of the infeasible options the only remaining control option is good combustion practices. MBFP has proposed a VOC emission rate of 0.0054 lb/MMBtu. The Division agrees that a VOC emission rate of 0.0054 lb/MMBtu based on good combustion practices is considered representative of BACT for the auxiliary boiler and process heaters process heaters (Catalyst Regenerator, Reactivation Heater, and HGT Reactor Charge Heater).

o **Startup Units (Gasifier Preheaters and Black Start Generators)**

The five (5) proposed gasifier preheaters are proposed at 21 MMBtu/hr and each gasifier preheater is expected to operate for no more than 500 hours per year (2,500 hours total for 5 preheaters). MBFP has proposed a VOC emission rate of 0.0054 lb/MMBtu for the gasifier preheaters based on good combustion practices. Based on the size and operation of these units, the Division considers the use of good combustion practices with a VOC emission rate of 0.0054 lb/MMBtu as being representative of BACT.

The three (3) Black Start Generators are 2,889 horsepower in size and each generator is anticipated to operate no more than 250 hours per year. MBFP has proposed a VOC emission rate of 0.9 g/hp-hr for these units. Based on the limited operating hours for these units the Division considers 0.9 g/hp-hr VOC to be representative of BACT.

o Storage Tanks

Control Options

MBFP identified the following technologies for the control of VOC emissions from the proposed storage tanks at the Medicine Bow IGL Plant:

- Operate tanks under pressure, as closed systems
- Fixed or dome roof tanks with vapor collection system routed to fuel gas system
- Fixed or dome roof tanks with vapor collection system routed to control device
- External floating roof
- Internal floating roof

Operating the tanks under pressure is an inherently less-polluting process configuration because it eliminates working and breathing losses associated with tanks. This option is suitable for materials that are gases at atmospheric pressure and temperature such as propane and butane.

Fixed or dome roof tanks with a vapor collection system capture vapors emitted from the liquids stored in a tank. These vapors are typically generated from working and breathing losses and changes in pressure (flashing losses). These vapors can potentially be routed to a fuel gas system or a control device such as a flare.

External or internal floating roof tanks operate by eliminating vapor space in a tank. The roof of the tank floats on top of the liquid in the tank and rises and lowers with the liquid level thus not allowing a space for flashing losses and minimizing working and breathing losses.

Eliminate Technically Infeasible Options

MBFP eliminated operating tanks under pressure for liquid storage (i.e. methanol and gasoline) at the facility; however, pressurized bullet tanks will be utilized to store LPG generated at the facility.

Fixed or dome roof tanks with a vapor collection system routed to a fuel gas system, based on the proposed tank sizes, was eliminated as the tanks would need to operate with a blanket system (inert gas) to prevent an explosive atmosphere in the tanks. In addition, the inert gas collected with the combustible vapors would not be compatible with any of the proposed fuel gas or process streams at the facility.

Rank Remaining Technologies

The remaining VOC control technologies for the storage tanks in order of control effectiveness are as follows: internal floating roof tanks, fixed or dome roof tanks with vapor collection routed to a control device, and external floating roof tanks.

Evaluate Remaining Technologies

MBFP has proposed IFR tanks as BACT for the gasoline product, methanol, heavy gasoline, and slop product tanks. Tanks that will contain liquids that are considered insignificant in emissions are proposed to be fixed roof tanks. The following table shows the proposed tanks at the facility:

Table IX Medicine Bow IGL Plant Storage Tanks			
Tank Name	No. of Tanks	Capacity of Tank (gallons)	Roof Type
Methanol Tanks	2	6,341,984	IFR
Gasoline Product Tanks	8	6,341,984	IFR
Heavy Gasoline Tank	1	4,763,841	IFR
Off-Spec Gasoline Tank	1	5,000	IFR
Off-Spec Methanol Tank	1	5,000	IFR
Slop Tank	1	7,000	IFR
Gray Water Tank	1	TBD	FR
Slurry Additive Tank	1	TBD	FR
Mill Discharge Tank	1	TBD	FR
Slurry Tank	1	TBD	FR
Injector Coolant Tank	1	TBD	FR
Settler	1	TBD	FR
Filter Feed Tank	1	TBD	FR
Filtrate Tank	1	TBD	FR
Glycol Storage Tank	1	TBD	FR
Sulfur Storage	2	TBD	FR
LPG	TBD	TBD	pressurized tanks

Note: IFR = Internal Floating Roof, FR = Fixed Roof, TBD = To Be Determined

MBFP considered fixed or dome roof tanks with vapor collection routed to a control device for the gasoline product, methanol, heavy gasoline, and slop product tanks to be a lower option because the installation of a control device will increase NO_x and CO emissions.

Select VOC BACT (Conclusion)

The Division considers the use of IFR tanks for the gasoline product, methanol, heavy gasoline, and slop product tanks to be representative of BACT. In addition, the Division considers the use of fixed roof tanks for liquids that are insignificant in emissions, and pressurized tanks for LPG storage to be representative of BACT.

o Fugitive Emissions

MBFP has proposed to operate a Leak Detection and Repair (LDAR) program to minimize fugitive emissions at the plant. The LDAR program is based on a leak detection level of 500 ppm for valves and connectors and a leak detection level of 2000 ppm for pumps. These levels are based on the requirements of Subpart VVa of 40 CFR part 60 which this facility is subject to. This program will be designed to inspect for leaks from piping components and equipment, and components found to be leaking in excess of stated thresholds are repaired. The Division considers the implementation of an LDAR program to be representative of BACT for fugitive emissions.

• **Particulate Emissions (Assumed to be PM₁₀)**

○ **Turbines**

Control Options

MBFP identified the following technologies for the control of particulate emissions from the proposed turbines at the Medicine Bow IGL Plant:

- Fuels with Low Potential Particulate Emissions (gaseous fuels)
- Good Combustion Practices (proper operation)
- Electrostatic Precipitation
- Baghouse

Electrostatic precipitation (ESP) is a post-combustion particulate control technology that removes particulates from gas using an induced electrostatic charge.

Baghouses are a post-combustion particulate control technology that utilizes a fine mesh filter to remove particulates from gases.

Eliminate Technically Infeasible Options

MBFP eliminated an ESP and baghouse as viable control options for particulate emissions from the turbines. This is due to the fact that particulate emissions from the turbines are estimated at 0.003 grains per dry standard cubic foot (gr/dscf), and the ESP and baghouse are not able to provide any further reduction.

Rank/Evaluate/Select BACT

With the elimination of the ESP and baghouse the only remaining control options are good combustion practices and fuels with low potential for particulate emissions. Fuel gases for the turbines are considered to have a low potential for particulate emissions. Therefore, the Division considers good combustion practices and fuels with low potential for particulate emissions as being representative of BACT.

○ **Auxiliary Boiler and Process Heaters**

MBFP identified the same particulate control technologies for the auxiliary boiler and process heaters as was identified for the turbines. Based on the relatively small amount of particulate emissions estimated for these gas fired sources MBFP considered an ESP and baghouse to be unreasonable. The Division agrees with MBFP and considers good combustion practices to be representative of BACT for these units.

o **Coal Storage and Material Handling**

MBFP has proposed to utilize atomizer/fogger systems and/or passive enclosure control systems (PECS) at coal transfer points at the Medicine Bow IGL Plant. The Division considers PECS and atomizer/fogger systems to be as efficient as traditional baghouse control devices, and is satisfied that the systems can operate as effective control devices on a continuous basis. The Division considers monitoring and proper maintenance of the PECS and atomizer/fogger systems to be critical to their control effectiveness.

The PECS and atomizer/fogger systems are to be operated and maintained so that the system enclosures exhibit no visible emissions. As a condition of this permit, the Division will establish a no visible emissions limit on the PECS and atomizer/fogger systems as determined by Method 22 of 40 CFR part 60, Appendix A. MBFP is to conduct daily inspections of each of the PECS and atomizer/fogger systems to determine the presence of visible emissions. Records of the daily observations are to be recorded, and if any emissions are noted, immediate corrective action is to be taken. Initial performance tests are to be conducted on the PECS and atomizer/fogger systems that will be utilized to control particulate emissions. Performance testing using Method 22 of 40 CFR part 60, Appendix A shall be conducted on the enclosure housing to determine that there are no visible fugitive particulate emissions. Performance tests shall be at least 30 minutes in duration, with observations taken from each side of the enclosure.

MBFP has proposed to use in-pit stacker tubes for storage of coal delivered from the underground mine. Before coming to this conclusion MBFP examined the following options for coal storage:

- Stacking tubes located at grade
- Stacking tubes located in-pit (below-grade)
- Covered slot storage

Stacking tubes are essentially large upright cylinders with staggered ports along the length of the tube. As coal is fed to the tube a stockpile is created around the tube. The base of the stacking tube typically consists of an area to reclaim the coal put in the pile.

Covered slot storage consists of an enclosed barn like structure where coal is stockpiled. Like stacking tubes the base of the slot storage contains a reclaim area for the coal.

Before evaluation of the options, MBFP assessed the degree of wind shelter provided by the East Portal pit based on a similar study conducted at the Bridger Coal Mine. At the Bridger Coal Mine a wind monitor was placed in pit and a second was placed at the top of the highwall. Wind speeds from these monitors were compared to estimate the degree of shelter afforded by the pit. Based on a comparison of the wind data from Seminole II (near Hanna) and how the pit will be constructed at the East Portal it was determined that there would only be a 25% reduction in wind speeds in pit (below-grade).

The following table shows the costs to control particulate emissions from the three (3) options for underground mine coal storage:

Control Technology	Cost	Emissions	Incremental Cost
Covered Slot Storage	\$157,200,000	0.0 tpy	\$54,119
Stacker Tubes In-Pit	\$84,700,000	60.2 tpy	\$6,902
Stacker Tubes at Grade	\$82,200,000	78.3 tpy	--

Based on the above cost, MBFP selected placing stacker tubes in-pit as representing BACT. The Division agrees with MBFP that that stacker tubes in-pit are considered representative of BACT.

For the 300,000 ton dead storage coal pile, which will be located between the active coal storage pile and IGL Plant, MBFP proposes to use a stacker tube and to use a sealant on the pile once it has reached its capacity. The Division considers the use of sealant on the 300,000 ton dead storage pile as representing BACT for this type of operation.

Coal sent to the plant from the storage piles is sent to enclosed storage bins prior to final coal preparation at the IGL Plant. The storage bins at the plant will contain enough coal for approximately 8 hours of plant operation. The Division considers enclosed coal storage at the IGL plant to represent BACT.

CHAPTER 6, SECTION 2 – BEST AVAILABLE CONTROL TECHNOLOGY (BACT):

Per the requirements of Chapter 6, Section 2 of the WAQSR, all facilities must demonstrate the use of BACT. Therefore, MBFP conducted a BACT analysis for the control of pollutants not addressed in the PSD BACT analyses in accordance with state requirements.

• SO₂ Emissions

○ Turbines

Control Options

MBFP identified the following technologies for the control of SO₂ emissions from the proposed turbines at the Medicine Bow IGL Plant:

- Chemical Absorption Acid Gas Removal (pre-combustion control)
- Physical Absorption Acid Gas Removal (pre-combustion control)
- Flue Gas Desulfurization

Chemical absorption methods are amine-based systems that utilize solvents, such as methyl-diethanolamine (MDEA) to bond with H₂S in the tail gas.

Physical absorption methods employ a solvent to remove sulfur from gas streams, such as mixtures of dimethyl ethers of polyethylene glycol or methanol. These systems operate by absorbing H₂S under physical pressure into the solvent.

Flue gas desulfurization is a post-combustion SO₂ control technology that reacts an alkaline compound with SO₂ in the exhaust gas.

Eliminate Technically Infeasible Options

Based on the design of the Medicine Bow IGL Plant chemical absorption was eliminated as technically infeasible as these systems would not remove enough sulfur for the methanol synthesis process. Syngas, which fuels the turbines, is used in the methanol synthesis process and in order for the methanol synthesis process to function properly the sulfur content in the gas must be less than 0.1 ppm sulfur.

Flue gas desulfurization (FGD) was eliminated from consideration as FGD systems have not been applied to gas fired turbines and the concentration of SO₂ in the flue gas stream in comparison to emission units which have required FGD for SO₂ control such as coal fired boilers is low.

Rank/Evaluate/Select BACT

Medicine Bow Fuel & Power, LLC has proposed physical absorption (SELEXOL[®]) as BACT for SO₂ control for the turbines. The SELEXOL[®] unit which treats the syngas for methanol synthesis essentially produces a low sulfur fuel for the turbines. The Division considers the use of physical absorption as being representative of BACT for SO₂ emissions from the turbines.

o **Sulfur Recovery Unit (SRU)**

Control Options

MBFP identified the following technologies for the control of SO₂ emissions from the SRU at the Medicine Bow IGL Plant:

- LP Flare
- Thermal Oxidizer (Tail Gas Incinerator)
- Re-routing Tail Gas back to SELEXOL[®] unit

Eliminate Technically Infeasible Options

No control options identified are considered technically infeasible.

Rank/Evaluate/Select BACT

Medicine Bow Fuel & Power, LLC has proposed to route tail gas from the SRU back to the SELEXOL[®] unit. This is considered the highest control option; therefore, further evaluation of the other options is not necessary. The Division considers routing tail gas from the SRU back to the SELEXOL[®] unit as being representative of BACT for SO₂ emissions from the SRU.

- **Mercury (Hg) Emissions**

MBFP has proposed to install two mercury guard beds (activated carbon) at the IGL Plant. These mercury guard beds are estimated to remove mercury by 99 percent. The cost to control mercury at the IGL Plant is estimated at \$235,164/ton of mercury removed. MBFP has proposed a mercury emission rate of 0.02 $\mu\text{g}/\text{Nm}^3$ which equates to mercury emissions of 4.33×10^{-5} tpy (0.087 lb/yr) per turbine. Total mercury emissions from the turbines are 0.00013 tpy. For comparison, the coal fired Basin Electric Dry Fork Station mercury emissions were estimated at 0.16 tpy. The Division considers the installation of mercury guard beds to be representative of BACT for mercury control at this facility.

STARTUP AND SHUTDOWN OPERATIONS:

- **Combustion Turbines**

The combustion turbines are expected to comply with BACT limits during all times including startup and shutdown based on the averaging periods for each pollutant emitted.

- **Boiler and Process Heaters**

The boiler and process heaters are expected to comply with BACT limits during all times including startup and shutdown for each pollutant emitted.

- **Engines**

All engines are expected to comply with BACT limits during all times including startup and shutdown for each pollutant emitted.

- **HP/LP Flares**

During initial startup operations and subsequent warm-start operations, syngas will be flared until downstream units are capable of accommodating the gas. Syngas from the gasifiers will be sent to the HP Flare until safety checks are complete. Once these checks are completed syngas will be diverted to downstream units (syngas conditioning and acid gas removal), as appropriate.

Clean syngas from the syngas conditioning and acid gas removal area will be sent to the LP Flare until the syngas reaches a specification of less than 0.5 ppmv. Acid gas from the SELEXOL[®] unit will be sent to the LP Flare until the acid gas reaches approximately 40% H₂S content. Once the appropriate H₂S content is reached the acid gas will be sent to the SRU for treatment.

- **CO₂ vent stack**

During initial startup operations and subsequent warm start operations, off-specification CO₂ will be vented to the atmosphere. CO₂ vent gas will contain CO and VOCs (primarily COS). This gas will be vented until there is a sufficient flow rate (25% of design flow rate or approximately 49 MMscfd of gas) to operate the CO₂ recovery compressors.

The Division has reviewed the Startup/Shutdown Emission Minimization Plan for the Medicine Bow IGL Plant and is satisfied that Medicine Bow Fuel & Power, LLC is taking the necessary steps to minimize emissions during these periods. The Division will allow this plan to be modified as necessary but revisions to the plan shall be provided to the Division with justifications for any revisions to the plan.

CHAPTER 6, SECTION 3 – MAJOR SOURCE APPLICABILITY:

The Division considers the Medicine Bow IGL Plant and Saddleback Hills Mine to be one facility. Therefore, the emissions from both facilities were considered together in determining major source applicability. Together the Medicine Bow IGL Plant and Saddleback Hills Mine are a “major source” as emissions of a criteria pollutant are greater than 100 tons per year, and HAP emissions are greater than 10 tpy of any individual HAP and 25 tpy of any combination of HAPs. Therefore, Medicine Bow Fuel & Power will need to obtain an Operating Permit in accordance with Chapter 6, Section 3 of the Wyoming Air Quality Standards and Regulations.

NEW SOURCE PERFORMANCE STANDARDS (NSPS):

The auxiliary boiler at the Medicine Bow IGL Plant will be subject to the requirements of 40 CFR part 60, Subpart Dc – *Standards of Performance for Small Industrial-Commercial-Institutional Steam Generating Units*. There are no limits under Subpart Dc for the auxiliary boiler as this unit is gas fired.

The combustion turbines at the Medicine Bow IGL Plant are subject to the requirements of 40 CFR part 60, Subpart KKKK – *Standards of Performance for Stationary Combustion Turbines*. This subpart limits NO_x emissions from the turbines firing fuels other than natural gas between 50 MMBtu/hr and 850 MMBtu/hr to 74 ppm at 15 percent O₂ or 3.6 lb/MWhr (of useful output). In addition to the NO_x limits, Subpart KKKK also specifies a SO₂ emission limit for new turbines that are located in continental areas of 0.9 lb/MW-hr gross energy output. In accordance with Subpart KKKK, Medicine Bow Fuel & Power, LLC may comply with the standard directly, or accept a limit of 0.060 lb SO₂/MMBtu on the sulfur content of the fuel.

The methanol tanks, gasoline product tanks, and heavy gasoline tank are subject to the requirements of 40 CFR part 60, Subpart Kb – *Standards of Performance for Volatile Organic Liquid Storage Vessels*. This subpart requires the tanks to meet certain design criteria or control requirements based on tank size and vapor pressure.

The coal preparation facilities at the Saddleback Hills Mine and Medicine Bow IGL Plant are subject to the requirements of 40 CFR part 60, Subpart Y – *Standards of Performance for Coal Preparation Plants*. Subpart Y limits the opacity from any coal processing and conveying equipment, including coal crushers and breakers, coal storage systems, and coal transfer and loading systems to less than twenty percent (20%). It should be noted that EPA has proposed amendments to Subpart Y. Under the proposed revisions, sources constructed after April 28, 2008 would be limited to less than five (5) percent opacity.

The Firewater pump engine is subject to the requirements of 40 CFR part 60, Subpart IIII – *Standards of Performance for Stationary Compression Ignition Internal Combustion Engines*. A section of this subpart sets limits for NMHC+NO_x, CO, and PM from fire pump engines.

The Black Start Generators are subject to the requirements of 40 CFR part 60, Subpart JJJJ – *Standards of Performance for Stationary Spark Ignition Internal Combustion Engines*. This subpart limits NO_x, CO, and VOC emissions from the engines and limits operating hours for emergency stationary internal combustion engines.

The Medicine Bow IGL Plant is subject to the requirements of 40 CFR part 60, Subpart VVa – *Standards of Performance for Equipment Leaks of VOC in the Synthetic Organic Chemicals Manufacturing Industry* as the facility produces methanol. This subpart establishes monitoring and repair standards for equipment leaks.

CHAPTER 6, SECTION 5 – PERMIT REQUIREMENTS FOR CONSTRUCTION AND MODIFICATION OF NESHAP SOURCES:

Chapter 6, Section 5(a)(iii) contains specific application requirements for construction or modification of sources subject to a NESHAP standard. MBFP has submitted their application in accordance with these requirements and has specifically addressed all items under Chapter 6, Section 5(a)(iii)(A)(II) within the application. They have identified that the proposed auxiliary boiler and process heaters will be subject to Chapter 5, Section 3, Subpart DDDDD, engines will be subject to 40 CFR part 63, Subpart ZZZZ, and the turbines will be subject to 40 CFR part 63, Subpart YYYYY.

NATIONAL EMISSION STANDARDS FOR HAZARDOUS AIR POLLUTANTS (NESHAP):

The boiler and heaters at the Medicine Bow IGL Plant are subject to Chapter 5, Section 3, Subpart DDDDD – *National Emission Standards for Hazardous Air Pollutants for Industrial, Commercial, and Institutional Boiler and Process Heaters*. This subpart limits CO emissions to 400 ppm by volume on a dry basis corrected to 3% O₂ for units less than 100 MMBtu/hr. This subpart would apply to the auxiliary boiler (AB), catalyst regenerator (B-1), reactivation heater (B-2), HGT reactor charge heater (B-3), and the gasifier preheaters (GP-1, GP-2, GP-3, GP-4, and GP-5). A conversion of 400 ppm_v CO to lb/MMBtu equates a value of 0.29 lb/MMBtu CO. The BACT limit of 0.08 lb/MMBtu CO for these units will demonstrate compliance with this regulation.

The Black Start Generators at the Medicine Bow IGL Plant are subject to the requirements of 40 CFR part 63, Subpart ZZZZ – *National Emission Standards for Hazardous Air Pollutants from Stationary Reciprocating Internal Combustion Engines*. However, the engines are not required to comply with the emission limitation or operating limitations of this subpart as the engines meet the definition of an emergency stationary RICE.

The combustion turbines at the Medicine Bow IGL Plant are subject to the requirements of 40 CFR part 63, Subpart YYYYY – *National Emission Standards for Hazardous Air Pollutants from Stationary Combustion Turbines*. Currently, the emissions and operating limitations for new turbines in the lean premix gas fired and diffusion flame gas fired turbine subcategories has been stayed by the EPA of which the proposed turbines fall into.

The Medicine Bow IGL Plant is subject to the requirements of 40 CFR part 63, Subpart H – *National Emission Standards for Organic Hazardous Air Pollutants for Equipment Leaks*, as the facility processes methanol.

The Medicine Bow IGL Plant is subject to the requirements of 40 CFR part 63, Subpart EEEE – *National Emission Standards for Hazardous Air Pollutants: Organic Liquids Distribution*, as the facility processes methanol.

PROJECTED IMPACT ON EXISTING AMBIENT AIR QUALITY:

Model Selection

The EPA-preferred dispersion model for near-field analyses (within 50 kilometers) is one developed by a working group called the AMS/EPA Regulatory Model Improvement Committee (AERMIC). The product of this workgroup's efforts, the AERMIC Model (AERMOD) was chosen by the EPA to replace ISC as the preferred near-field model, as described in the EPA's Guideline on Air Quality Models (GAQM, Appendix W of 40 CFR Part 51).

Several components of AERMOD represent improvements over those contained within the ISC model, including the advanced treatment of turbulence and dispersion in the planetary boundary layer, plume interaction with terrain, and building downwash. The AERMOD modeling system consists of two preprocessors and a dispersion model. The two preprocessors are: 1) the AERMET meteorological preprocessor, and 2) the AERMAP terrain and receptor grid preprocessor.

The applicant used version 07026 of AERMOD to evaluate potential concentrations for comparison to the Wyoming Ambient Air Quality Standards (WAAQS), National Ambient Air Quality Standards (NAAQS), and PSD increments. The Division reviewed the applicant's model runs to verify proper model setup. Modeling results reported here were obtained from the Division's verification model runs. All model runs used the recommended regulatory default options for AERMOD:

- No exponential decay
- Elevated terrain effects
- Stack-tip downwash
- Calms processing
- Missing meteorological data processing

Meteorological Data

To determine the most suitable source of meteorological data to drive AERMOD, the applicant examined data from three possible sites, as listed below:

- Elmo, Wyoming – located approximately 24 kilometers (km) northwest of the proposed plant
- Rawlins, Wyoming Municipal Airport – A National Weather Service (NWS) station located approximately 70 km west of the proposed plant site
- Laramie, Wyoming Regional Airport – A NWS station located approximately 73 km southeast of the proposed plant site

Given the proximity of the Elmo site, it was chosen as the most representative of the proposed project site. According to the applicant, Inter-Mountain Labs operated the Elmo station in accordance with the EPA guidance document *Meteorological Monitoring Guidance for Regulatory Modeling Applications* (EPA-454/R-99-005), performed semi-annual quality assurance audits on the station, and conducted quality control procedures on the data. Data input to AERMET from the Elmo station included 2-meter (m) temperature and 10-m wind speed and wind direction. Quarterly data recovery for the years 2000 through 2005 was greater than 90% for each year with the exception of 2002, and therefore data from the five-year period 2000-2001 and 2003-2005 was processed for use with AERMOD.

Because no solar radiation or temperature difference data were available from Elmo, cloud-cover data from the nearest NWS stations were input to AERMET. The preferred site was the NWS station at the Rawlins Municipal Airport, which was used for the years 2001 and 2004-2005. For the years 2000 and 2003, cloud-cover data recovery from Rawlins was not adequate, and data from Laramie was used as a substitute. The cloud-cover data are used by AERMET in combination with measured parameters to determine heat fluxes and atmospheric stability.

Upper-air data to combine with the surface data were taken from the nearest station that collects upper-air data, the NWS station at the Regional Airport at Riverton, Wyoming.

The applicant processed the data with the latest version (06431) of AERMET. Seasonal values for albedo, Bowen ratio, and surface roughness length that are typical for “desert shrubland” and “grassland”, as listed in Tables 4-1, 4-2b, and 4-3 in the AERMET User’s Guide, were averaged and input for Stage 3 processing within AERMET. These surface characteristics were applied for all wind direction sectors because of the uniformity of the land use in the vicinity of the meteorological measurement sites.

A wind rose for the 2005 data from Elmo is presented as Figure 2.

Figure 2 - Wind Rose for Elmo, Wyoming (2005)

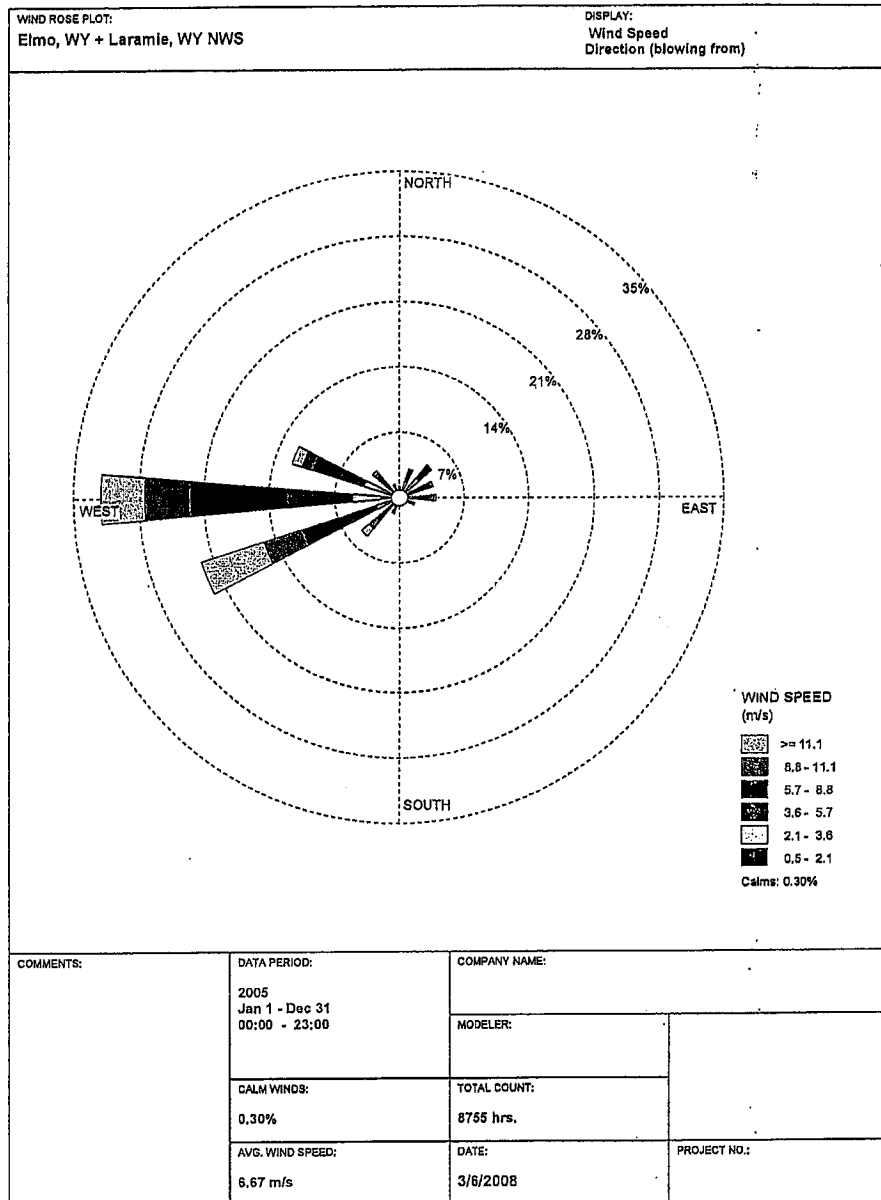

WRPLOT View - Lakes Environmental Software

Background Concentrations

Output from the AERMOD model was compared to the WAAQS/NAAQS after the addition of background concentrations that represent all emission sources that were not explicitly modeled. The background levels that were deemed appropriate for this project are shown in the table below.

Table XI Background Concentrations		
Pollutant	Averaging Period	Background Concentration ($\mu\text{g}/\text{m}^3$)
CO	1-Hour	1946
	8-Hour	916
NO ₂	Annual	9.4
PM ₁₀	24-Hour	56
	Annual	26
SO ₂	3-Hour	31.4
	24-Hour	7.8
	Annual	2.6

Notes:
 All background concentrations were measured in 2005
 CO values are second highest values measured at Yellowstone National Park
 NO₂ value is annual average measured at Antelope Site 3, Converse County
 PM₁₀ values are second highest or annual average measured at Mountain Cement Co. in Laramie
 SO₂ values are second highest or annual average measured at 90 Gas Hill Road in Riverton
 CO = carbon monoxide
 NO₂ = nitrogen dioxide
 PM₁₀ = particulate matter less than 10 microns
 SO₂ = sulfur dioxide
 $\mu\text{g}/\text{m}^3$ = micrograms per cubic meter

Receptor Grid

The dispersion modeling analysis was conducted with a discrete Cartesian receptor grid that included 2,161 receptors distributed as follows:

- 50-meter (m) spacing along the ambient boundary of the proposed IGL plant
- 100-m spacing to a distance of approximately 1 kilometers (km) beyond the ambient boundary
- 500-m spacing to a distance of approximately 5 km beyond the ambient boundary
- 1000-m spacing to a distance of approximately 10 km beyond the ambient boundary

For the particulate matter (PM₁₀) analysis, a 500-m receptor buffer was established around the coal mine area sources outside of the IGL plant boundary to avoid the prediction of excessive concentrations with receptors very near (or within) those area sources.

Receptor elevations and hill heights, as well as source and building base elevations for input to AERMOD, were determined from electronic data contained in USGS 7.5-minute Digital Elevation Model (DEM) files using EPA's AERMAP (06341) program. The base receptor grid configuration and the terrain patterns for the modeling domain, as generated from AERMAP output, are shown in Figure 3.

Figure 3 – Base AERMOD Receptor Grid

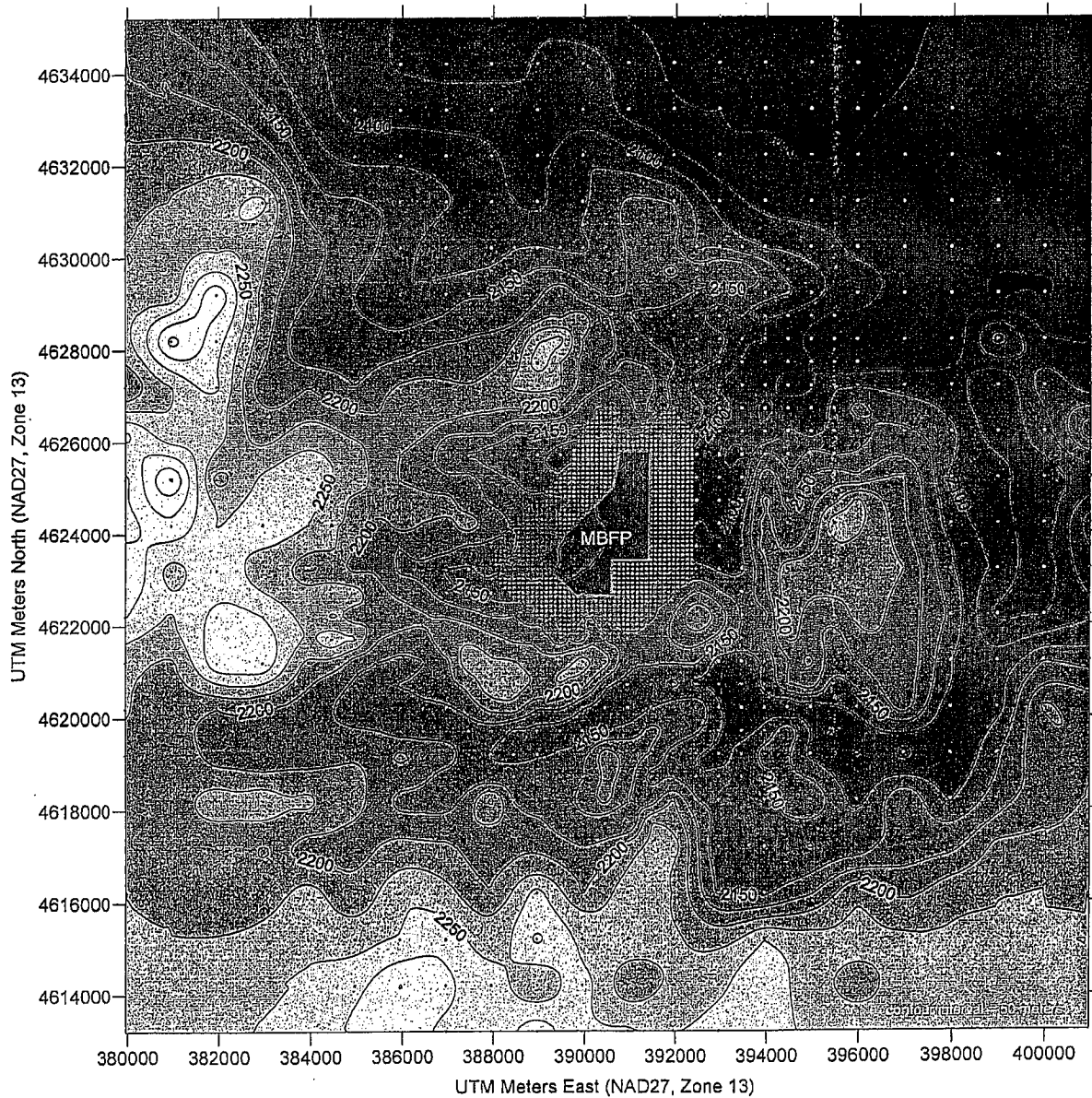

Building Profile Input Program

Building downwash was considered in the modeling analysis for the IGL Plant sources by entering building corners and heights into the EPA's Building Profile Input Program (BPIP-PRIME). Point sources for the IGL Plant were modeled with stack heights that were below Good Engineering Practice (GEP) stack heights.

Emissions and Stack Parameters

The near-field impact analysis conducted by the applicant reflected the plant configuration in year four of project development, when normal IGL plant operations will have begun. Also during year four of development, all coal produced at the underground Saddleback Hills Mine will be brought out from the mine's East Portal (Source ID MineA_EP). Mine development at the South Portal of the underground mine (Source ID MineA_SP) will cease in year four.

Source locations within the ambient boundary at the IGL Plant are shown in Figure 4. Stack parameters and emissions for the IGL Plant sources are shown in the following tables. Stack parameters and emissions for outside sources that were included in the modeling are included in Appendix A. All inputs for the outside sources were compiled by the Division based on inventory databases, permits, and previous modeling exercises.

Release parameters for the IGL Plant flares, including effective stack heights and effective diameters, were calculated by the applicant. These calculations are presented in Appendix A.

Figure 4 – Point and Volume Sources, Structures for Proposed IGL Plant

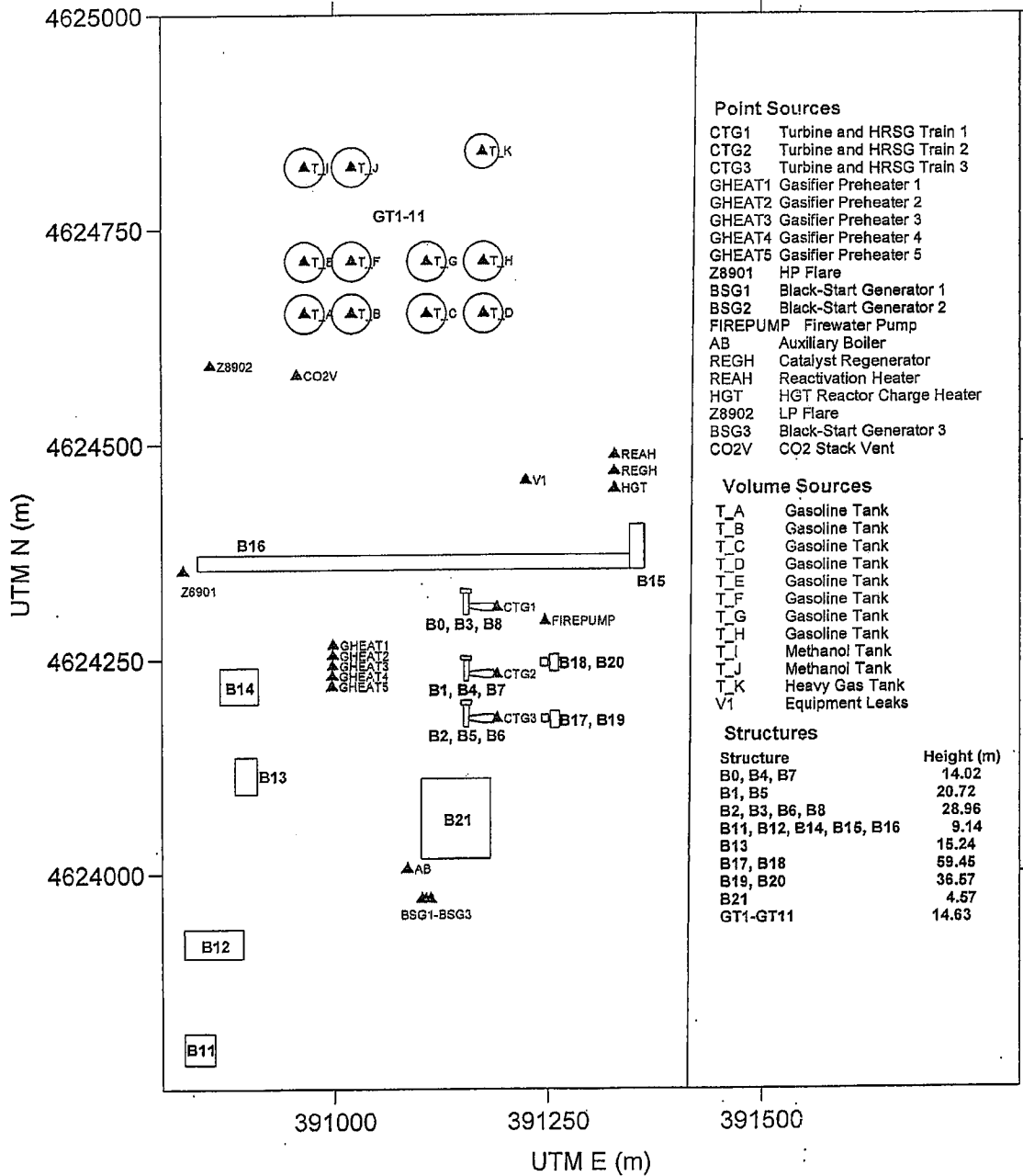

Table XII
Point Source Release Parameters for IGL Plant

Source ID	Source Description	UTM East (m)	UTM North (m)	Base Elev. (m)	Stack Height (m)	Temp. (K)	Exit Velocity (m/s)	Stack Diam. (m)
Point Sources								
CTG1	Turbine and HRSG Train 1	391190	4624310	2121	45.73	366.5	7.65	5.79
CTG2	Turbine and HRSG Train 2	391190	4624232	2121	45.73	366.5	7.65	5.79
CTG3	Turbine and HRSG Train 3	391190	4624180	2120	45.73	366.5	7.65	5.79
GHEAT1	Gasifier Preheater 1	390999	4624266	2132	25.91	422.1	7.45	0.41
GHEAT2	Gasifier Preheater 2	390998	4624254	2131	25.91	422.1	7.45	0.41
GHEAT3	Gasifier Preheater 3	390998	4624242	2130	25.91	422.1	7.45	0.41
GHEAT4	Gasifier Preheater 4	390998	4624230	2129	25.91	422.1	7.45	0.41
GHEAT5	Gasifier Preheater 5	390997	4624217	2129	25.91	422.1	7.45	0.41
Z8901	HP Flare	390825	4624353	2139	86.55*	1273.0	20	13.64*
BSG1	Black-Start Generator 1	391103	4623971	2123	30	767.6	1.96	0.41
BSG2	Black-Start Generator 2	391108	4623971	2123	30	767.6	1.96	0.41
FIREPUMP	Firewater Pump	391247	4624294	2120	6.1	739.3	45	0.15
AB	Auxiliary Boiler	391086	4624006	2125	15.24	422.1	1.6	0.91
REGH	Catalyst Regenerator	391329	4624468	2114	15.24	422.1	1.6	0.91
REAH	Reactivation Heater	391330	4624486	2113	15.24	422.1	1.6	0.91
HGT	HGT Reactor Charge Heater	391329	4624448	2114	15.24	422.1	1.6	0.91
Z8902	LP Flare	390856	4624591	2131	78*	1273.0	20	1.35*
BSG3	Black-Start Generator 3	391113	4623971	2123	30	767.6	1.96	0.41
CO2V	CO ₂ Stack Vent	390957	4624580	2129	30.49	297.0	6.99	1.83

* Stack heights and diameters for flares are calculated "effective" values, actual LP ht = 241 ft, actual HP ht = 150 ft.

UTM Coordinates expressed in NAD 27, Zone 13

Table XIII - Point Source Emissions for IGL Plant

Source ID	Source Description	Annual PM ₁₀ Emission Rate (g/s)	24-Hour PM ₁₀ Emission Rate (g/s)	Short-term CO Emission Rate (g/s)	Annual SO ₂ Emission Rate (g/s)	Short-Term SO ₂ Emission Rate (g/s)	Annual NO _x Emission Rate (g/s)
CTG1	Turbine and HRSG Train 1	1.26	1.26	2.3801	0.336	0.336	2.35
CTG2	Turbine and HRSG Train 2	1.26	1.26	2.3801	0.336	0.336	2.35
CTG3	Turbine and HRSG Train 3	1.26	1.26	2.3801	0.336	0.336	2.35
GHEAT1	Gasifier Preheater 1	0.0011	0.0197	0.2180	8.80E-05	0.0015	0.0074
GHEAT2	Gasifier Preheater 2	0.0011	0.0197	0.2180	8.80E-05	0.0015	0.0074
GHEAT3	Gasifier Preheater 3	0.0011	0.0197	0.2180	8.80E-05	0.0015	0.0074
GHEAT4	Gasifier Preheater 4	0.0011	0.0197	0.2180	8.80E-05	0.0015	0.0074
GHEAT5	Gasifier Preheater 5	0.0011	0.0197	0.2180	8.80E-05	0.0015	0.0074
Z8901	HP Flare	0	0	409.40	5.40	946.02	0.2956
BSG1	Black-Start Generator 1	7.80E-06	1.90E-04	1.95	5.90E-05	0.0014	0.0330
BSG2	Black-Start Generator 2	7.80E-06	1.90E-04	1.95	5.90E-05	0.0014	0.0330
FIREPUMP	Firewater Pump	0.0006	0.0096	0.046	4.40E-05	7.64E-04	0.0433
AB	Auxiliary Boiler	0.0620	0.0620	0.685	0.005	0.005	0.4076
REGH	Catalyst Regenerator	0.0202	0.0202	0.223	0.0016	0.0016	0.1330
REAH	Reactivation Heater	0.0117	0.0117	0.129	9.20E-04	9.20E-04	0.0770
HGT	HGT Reactor Charge Heater	0.0021	0.0021	0.023	1.60E-04	1.60E-04	0.0140
Z8902	LP Flare	0	0	2.440	1.036	453.75	0.0044
BSG3	Black-Start Generator 3	7.80E-06	1.90E-04	1.95	5.90E-05	0.0014	0.0330
CO2V	CO ₂ Stack Vent	0	0	423.21	0	0	0

Notes:

- CO emissions from CTG1-3, CO2V, GHEAT1-5, and BSG1-3 are worst-case (cold start) hourly conditions
- CO and short-term SO₂ emissions from the flares (Z8901 and Z8902) represent worst-case (plant malfunction or cold start) hourly conditions
- Worst-case emissions from turbines (CTG1-3) from manufacturer's guarantee for 0°F case (NO_x, CO, SO₂)
- Annual emissions from HP Flare based on 50 hrs/yr in malfunction or cold start, remainder of year in pilot
- Annual emissions from LP Flare based on 20 hrs/yr in malfunction or cold start, remainder of year in pilot
- Annual emissions from turbines (CTG1-3) based on 6 hrs/yr in cold start mode, remainder of year in normal operation (assumed to be 0°F case)
- Annual emissions from preheaters (GHEAT1-5) based on 500 hr/yr operation
- Annual emissions from black-start generators (BSG1-3) based on 360 hr/yr operation
- Annual emissions from firewater pump (FIREPUMP) based on 500 hr/yr operation

WYOMING AMBIENT AIR QUALITY STANDARDS (WAAQS) ANALYSIS

Particulate Matter (PM₁₀)

Impacts of particulate matter (PM₁₀) from operation of the IGL Plant were estimated by modeling PM₁₀ emissions from the IGL Plant, the Saddleback Hills underground coal mine, and the Elk Mountain surface coal mine. No significant sources of PM₁₀ outside of the IGL Plant are located within the modeling domain.

As described earlier, the impact analysis was conducted to reflect the plant configuration in year four of development, during which normal IGL plant operations will have begun and all coal produced at the underground Saddleback Hills Mine will be brought out from the mine's East Portal (Source ID MineA_EP). Emissions from the two nearby coal mines were taken from the application associated with the permit (CT-4136) that was granted for the combined (Saddleback + Elk Mountain) mining operation, the Carbon Basin Mines.

The haul road emissions from hauling coal from the Elk Mountain Mine (110.5 tpy), were taken from the application for CT-4136, and distributed across 112 volume sources that follow the path of the haul road toward Highway 72 (see Figure 6 below).

The locations of the area sources that were used to represent the coal mining operations are shown in the following figure. Emissions from those area sources are shown in the following tables.

Current Division policy does not endorse modeling as a viable tool in predicting short-term (24-hour) ambient impacts from fugitive particulate emissions. This is because the current techniques for estimating short-term fugitive emissions and the recommended EPA dispersion models have not proven to be reliable for evaluating short-term impacts. Therefore, dispersion modeling was used to determine short-term (24-hour) impacts for point sources only. Long-term (annual) average PM₁₀ impacts were determined using all source types.

Compliance with the 24-hour air quality standards for PM₁₀ is based on the second-highest predicted impact at each receptor, and therefore the overall highest second-high (HSH) predicted impact (plus background) was compared to the 24-hour NAAQS/WAAQS. The HSH predicted 24-hour impact (without background) was compared to the 24-hour PSD increment.

All sources at the proposed IGL Plant and adjacent coal mines were considered to be increment-consuming sources for purposes of determining compliance with the PSD increments.

Figure 5 – Area Source Locations

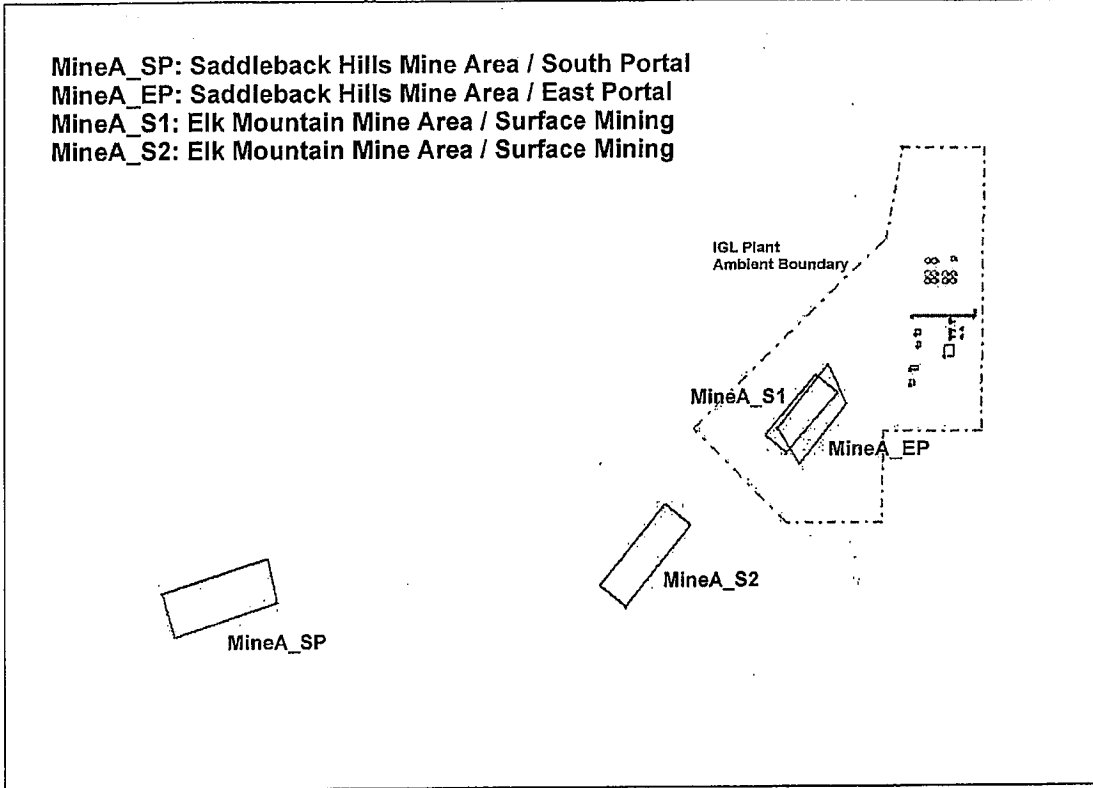

Figure 6 - Haul Road Volume Source Locations

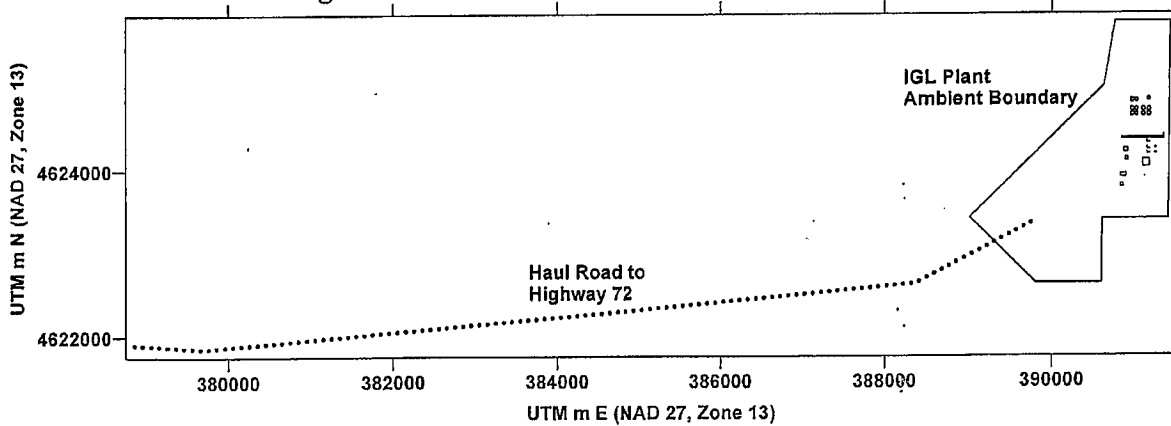

Table XIV - Modeled Area Sources for PM₁₀

Source ID	Source Description	UTM East (m)	UTM North (m)	UTM Elevation (m)	Base Elevation (m)	Release Height (m)	Sigma Z (m)	Number of Vertices	Area (m ²)	Annual PM ₁₀ Emission Rate (g/s/m ²)	Annual PM ₁₀ Emission Rate (g/s)	Annual PM ₁₀ Emission Rate (tpy)
MineA_SP	Saddleback Hills Mine Area / South Portal	384525.3	4622056.5	2229.0		12	13.95	4	351416.6	0	0	0
MineA_EP	Saddleback Hills Mine Area / East Portal	389721.7	4623411.5	2163.9		12	13.95	4	215535.4	8.2E-06	1.767	61.4

- Notes:
1. Emissions from the Saddleback Hills Mine taken from the 2005 permit application for the Carbon Basin Mines (Permit CT-4136)
 2. UTM Coordinates expressed in NAD 27, Zone 13
 3. South Portal will be active during plant development, but operations will cease after plant operations commence

Table XV - Modeled Open Pit Sources for PM₁₀

Source ID	Source Description	UTM East (m)	UTM North (m)	UTM Elevation (m)	Base Elevation (m)	Release Height (m)	Easterly Length (m)	Northerly Length (m)	Pit Volume (m ³)	Angle	Annual PM ₁₀ Emission Rate (g/s/m ²)	Annual PM ₁₀ Emission Rate (g/s)	Annual PM ₁₀ Emission Rate (tpy)
MineA_S1	Elk Mountain Mine Area / Surface Mining	389797.4	4623207	2133.8		6	661.1	234.8	4340000	-49.7	0.000007	1.087	37.8
MineA_S2	Elk Mountain Mine Area / Surface Mining	388439.2	4621926	2168.1		6	874.2	283.1	6750000	-51	0.000007	1.732	60.2

- Notes:
1. Emissions from the Elk Mountain Mine were taken from the 2005 permit application for the Carbon Basin Mines (Permit CT-4136)
 2. UTM Coordinates expressed in NAD 27, Zone 13
 3. Open Pit Model Inputs – PARTDIAM: 2.5, 10; MASSFRAX: 0.3, 0.7; PARTDENS: 1, 1
 4. Total Elk Mountain PM₁₀ emissions from CT-4136 = 71 tpy (from material transfers, tailpipe emissions, overburden removal, blasting, etc.). Modeled emissions were conservative (higher).

The HSH predicted 24-hour PM₁₀ impact of 7.1 µg/m³ occurred at the eastern ambient boundary of the IGL Plant. With the addition of the background level of 56 µg/m³, the total predicted impact is 63.1 µg/m³. This value is below the WAAQS/NAAQS of 150 µg/m³.

Maximum predicted annual impacts (14.4 µg/m³) occurred along the southwest portion of the ambient boundary of the IGL Plant. With the addition of the background level of 26 µg/m³, the total predicted annual impact is 40.4 µg/m³, which is well below the WAAQS of 50 µg/m³.

Predicted PSD increment consumption was well below allowable levels for both the 24-hour and annual averaging periods. Results of the PM₁₀ modeling are presented in the tables below.

Table XVI Results of WAAQS/NAAQS Analysis for PM ₁₀					
Year	Averaging Time	Modeled Impact (µg/m ³) ¹	Background Concentration (µg/m ³)	Total Modeled Impact (µg/m ³)	WAAQS/NAAQS (µg/m ³)
2000	24-Hour	5.9	56	61.9	150
2001		5.5		61.5	
2003		7.1		63.1	
2004		5.5		61.5	
2005		5.4		61.4	
2000	Annual	14.0	26	40.0	50
2001		14.0		40.0	
2003		13.3		39.3	
2004		14.4		40.4	
2005		14.3		40.3	

¹ The reported 24-hour impacts are the highest second-high impacts

NAAQS = National Ambient Air Quality Standards

PM₁₀ = particulate matter

µg/m³ = micrograms per cubic meter

WAAQS = Wyoming Ambient Air Quality Standards

Year	Averaging Time	Modeled Impact (µg/m ³) ¹	PSD Increment (µg/m ³)
2000	24-Hour	5.9	30
2001		5.5	
2003		7.1	
2004		5.5	
2005		5.4	
2000	Annual	14.0	17
2001		14.0	
2003		13.3	
2004		14.4	
2005		14.3	

¹ The reported 24-hour impacts are the highest second-high impacts
 PM₁₀ = particulate matter
 PSD = Prevention of Significant Deterioration
 µg/m³ = micrograms per cubic meter

Carbon Monoxide (CO)

Sources of CO emissions from the IGL Plant and other sources within the modeling domain (listed in Appendix A) were modeled to determine compliance with the WAAQS/NAAQS for CO. Compliance with the air quality standards for CO is based on the second-highest predicted impact at each receptor, and therefore the overall highest second-high (HSH) predicted impact (plus background) was compared to the NAAQS/WAAQS. For both the 1-hour (37,228.2 µg/m³) and 8-hour (4,673.5 µg/m³) averaging periods, the HSH predicted impacts occurred approximately 1.5 km southeast of the IGL Plant. The maximum predicted impacts occurred in an area of 100-m receptor spacing that was added to the base receptor grid after preliminary maximums were predicted to occur in coarse receptor spacing.

With the addition of the background level of 1,946 µg/m³, the total estimated 1-hour impact is 39,174.2 µg/m³, which is 98% of the 1-hour NAAQS/WAAQS. Nearly all of this predicted impact is attributable to the CO₂ Vent source (CO₂V). For example, the year of meteorology (2001) that yields the highest predicted impact returns a HSH 1-hour impact of only 1,308.6 µg/m³ if the CO₂ Vent source is removed from consideration.

For the 8-hour averaging period, the fine-spaced grid yielded a HSH impact of 4,673.5 µg/m³. With the addition of the background level of 916 µg/m³, the total estimated impact is 5,589.5 µg/m³. This level is well below the NAAQS/WAAQS of 10,000 µg/m³. As with the predicted 1-hour impacts, nearly all of this predicted 8-hour impact is attributable to the CO₂ Vent source (CO₂V). The year of meteorology (2001) that yields the highest predicted impact returns a HSH 8-hour impact of only 166.4 µg/m³ if the CO₂ Vent source is removed from consideration.

The CO₂ Vent source will only operate during initial (cold) start and subsequent warm start operations. Given that the source was modeled with worst-case emissions associated with a cold start, and the infrequent nature of the source's operation, the reported modeling results represent a conservative estimate of CO impacts. Results of the CO analysis are summarized in the table below.

Year	Averaging Time	Modeled Impact ($\mu\text{g}/\text{m}^3$) ¹	Background Concentration ($\mu\text{g}/\text{m}^3$)	Total Modeled Impact ($\mu\text{g}/\text{m}^3$)	WAAQS/NAAQS ($\mu\text{g}/\text{m}^3$)
2000	1-Hour	31,331.7	1,946	33,277.7	40,000
2001		37,228.2		39,174.2	
2003		28,900.7		30,846.7	
2004		32,325.2		34,271.2	
2005		34,871.4		36,817.4	
2000	8-Hour	3,930.0	916	4,846.0	10,000
2001		4,673.5		5,589.5	
2003		4,268.3		5,184.3	
2004		4,651.2		5,567.2	
2005		4,388.5		5,304.5	

¹ The reported impacts are the highest overall second-high impacts from the base receptor grid or fine-spaced grid
 NAAQS = National Ambient Air Quality Standards
 CO = carbon monoxide
 $\mu\text{g}/\text{m}^3$ = micrograms per cubic meter
 WAAQS = Wyoming Ambient Air Quality Standards

Sulfur Dioxide (SO₂)

Sources of SO₂ emissions from the IGL Plant facility were modeled to determine compliance with the WAAQS/NAAQS for SO₂. Compliance with the short-term (3-hour and 24-hour) air quality standards for SO₂ are based on the second highest predicted impact at each receptor, and therefore the overall highest second-high (HSH) predicted impact (plus background) for each averaging period was compared to the NAAQS/WAAQS.

The HSH predicted 3-hour SO₂ impact of 1,127 $\mu\text{g}/\text{m}^3$ occurred approximately 3.5 km northwest of the IGL Plant. The maximum predicted impact occurred in an area of 100-m receptor spacing that was added to the base receptor grid after preliminary maximums were predicted to occur in coarse receptor spacing. With the addition of the background level of 31.4 $\mu\text{g}/\text{m}^3$, the total predicted impact is 1158.4 $\mu\text{g}/\text{m}^3$. This value is below the WAAQS/NAAQS of 1,300 $\mu\text{g}/\text{m}^3$. More than 99% of the maximum model-predicted 3-hour impact is due to the LP Flare (Z8902) operating in malfunction/cold start mode.

The HSH predicted 24-hour SO₂ impact of 236.4 $\mu\text{g}/\text{m}^3$ occurred approximately 4 km east of the eastern ambient boundary of the IGL Plant facility. The maximum predicted impacts occurred in an area of 100-m receptor spacing that was added to the base receptor grid after preliminary maximums were predicted to occur in coarse receptor spacing. With the addition of the background level of 7.8 $\mu\text{g}/\text{m}^3$, the total predicted impact is 244.2 $\mu\text{g}/\text{m}^3$. This value is below the WAAQS of 260 $\mu\text{g}/\text{m}^3$. More than 99% of the maximum model-predicted 24-hour impact is due to the LP Flare (Z8902) operating in malfunction/cold start mode.

The LP Flare was modeled with worst-case emissions associated with startup or malfunction. Given the infrequent nature of the source's operation at these higher emission rates, the reported modeling results represent a conservative estimate of short-term SO₂ impacts.

Maximum predicted annual impacts, occurring at the eastern ambient boundary of the IGL Plant facility, were $0.44 \mu\text{g}/\text{m}^3$. With the addition of the background level of $2.6 \mu\text{g}/\text{m}^3$, the total predicted impact is $3.0 \mu\text{g}/\text{m}^3$, which is well below the WAAQS of $60 \mu\text{g}/\text{m}^3$. Results of the SO_2 modeling are presented in the table below.

Table XIX Results of WAAQS/NAAQS Analysis for SO_2					
Year	Averaging Time	Modeled Impact ($\mu\text{g}/\text{m}^3$) ¹	Background Concentration ($\mu\text{g}/\text{m}^3$)	Total Modeled Impact ($\mu\text{g}/\text{m}^3$)	WAAQS/NAAQS ($\mu\text{g}/\text{m}^3$)
2000	3-Hour	1055	31.4	1086.4	1,300
2001		1127		1158.4	
2003		1021.2		1052.6	
2004		1016.2		1047.6	
2005		1085.1		1116.5	
2000	24-Hour	174.4	7.8	182.2	260/365
2001		176.5		184.3	
2003		177.7		185.5	
2004		236.4		244.2	
2005		190.3		198.1	
2000	Annual	0.36	2.6	2.96	60/80
2001		0.37		2.97	
2003		0.44		3.04	
2004		0.33		2.93	
2005		0.34		2.94	

¹The reported 3-hour and 24-hour impacts are the highest second-high impacts
 NAAQS = National Ambient Air Quality Standards
 SO_2 = sulfur dioxide
 $\mu\text{g}/\text{m}^3$ = micrograms per cubic meter
 WAAQS = Wyoming Ambient Air Quality Standards

Potential SO_2 impacts from the IGL Plant were also compared to the allowable PSD increments. For the PSD increment modeling, the flares (LP Flare and HP Flare) were excluded because operation of those sources will only occur during non-routine plant operations. All other sources of SO_2 were considered to be increment-consuming sources. Predicted PSD increment consumption was well below allowable levels for all averaging periods. Results of the PSD increment modeling are shown in the following table.

Table XX Results of PSD Increment Analysis for SO ₂			
Year	Averaging Time	Total Modeled Impact (µg/m ³)	PSD Increment (µg/m ³)
2000	3-Hour	3.0	512
2001		3.4	
2003		3.5	
2004		4.0	
2005		3.1	
2000	24-Hour	1.5	91
2001		1.4	
2003		1.8	
2004		1.4	
2005		1.3	
2000	Annual	0.31	20
2001		0.31	
2003		0.40	
2004		0.27	
2005		0.26	

The reported 3-hour and 24-hour impacts are the highest second-high impacts
 PSD = Prevention of Significant Deterioration
 SO₂ = sulfur dioxide
 µg/m³ = micrograms per cubic meter

Nitrogen Dioxide (NO₂)

Sources of nitrogen oxide (NO_x) emissions from the IGL Plant and other sources within the modeling domain (see Appendix A) were modeled to determine compliance with the annual WAAQS/NAAQS for NO₂. The maximum predicted annual impact of 4.9 µg/m³ was predicted to occur at the eastern ambient boundary of the SGL Plant.

This result was obtained using the conservative assumption that 100% of the NO_x emissions convert to NO₂. Using the national default NO₂/NO_x ratio of 0.75, as allowed by the GAQM, the maximum predicted impact is 3.7 µg/m³. With the addition of the background level of 9.4 µg/m³, the total predicted impact is 13.1 µg/m³. This predicted impact is well below the WAAQS/NAAQS for NO₂ of 100 µg/m³.

Predicted PSD increment consumption was well below the allowable level. Results of the modeling are summarized in the following tables.

Table XXI
Results of WAAQS/NAAQS Analysis for NO₂

Year	Maximum Modeled Annual NO ₂ Conc. (µg/m ³)	Background Annual NO ₂ Conc. (µg/m ³)	Total Predicted NO ₂ Conc. (µg/m ³)	WAAQS/NAAQS (µg/m ³)
2000	3.5	9.4	12.9	100
2001	3.3		12.7	
2003	3.7		13.1	
2004	2.6		12.0	
2005	2.7		12.1	

NAAQS = National Ambient Air Quality Standards
 NO₂ = nitrogen dioxide
 µg/m³ = micrograms per cubic meter
 WAAQS = Wyoming Ambient Air Quality Standards

Table XXII
Results of PSD Increment Analysis for NO₂

Year	Maximum Modeled Annual NO ₂ Conc. (µg/m ³)	PSD Increment (µg/m ³)
2000	3.5	25
2001	3.3	
2003	3.7	
2004	2.6	
2005	2.7	

NO₂ = nitrogen dioxide
 PSD = prevention of significant deterioration
 µg/m³ = micrograms per cubic meter

The locations of the maximum predicted impacts for all modeled pollutants for the WAAQS/NAAQS and PSD increment analyses are shown in the figures below.

Figure 7 - Locations of Modeled Maximums (WAAQS/NAAQS)

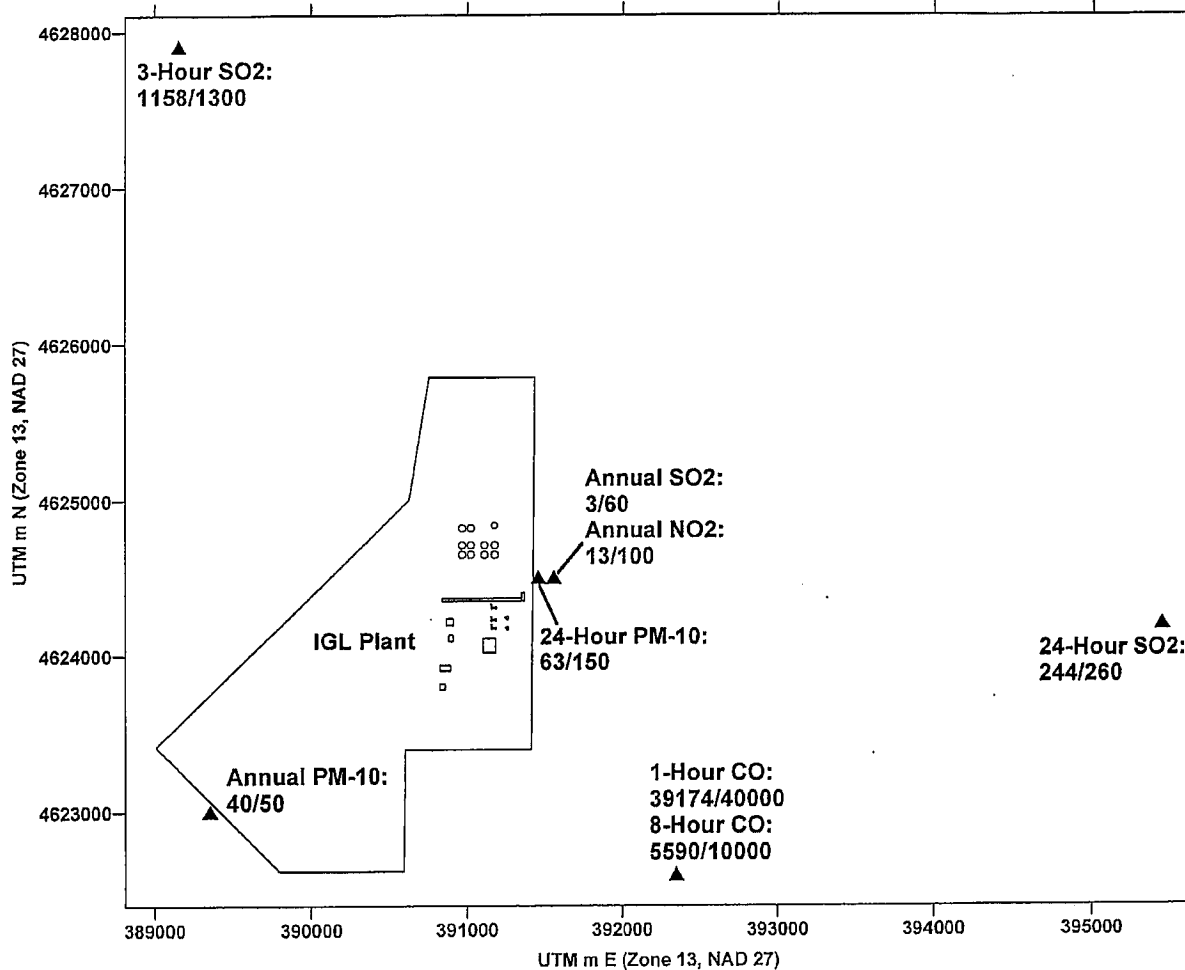
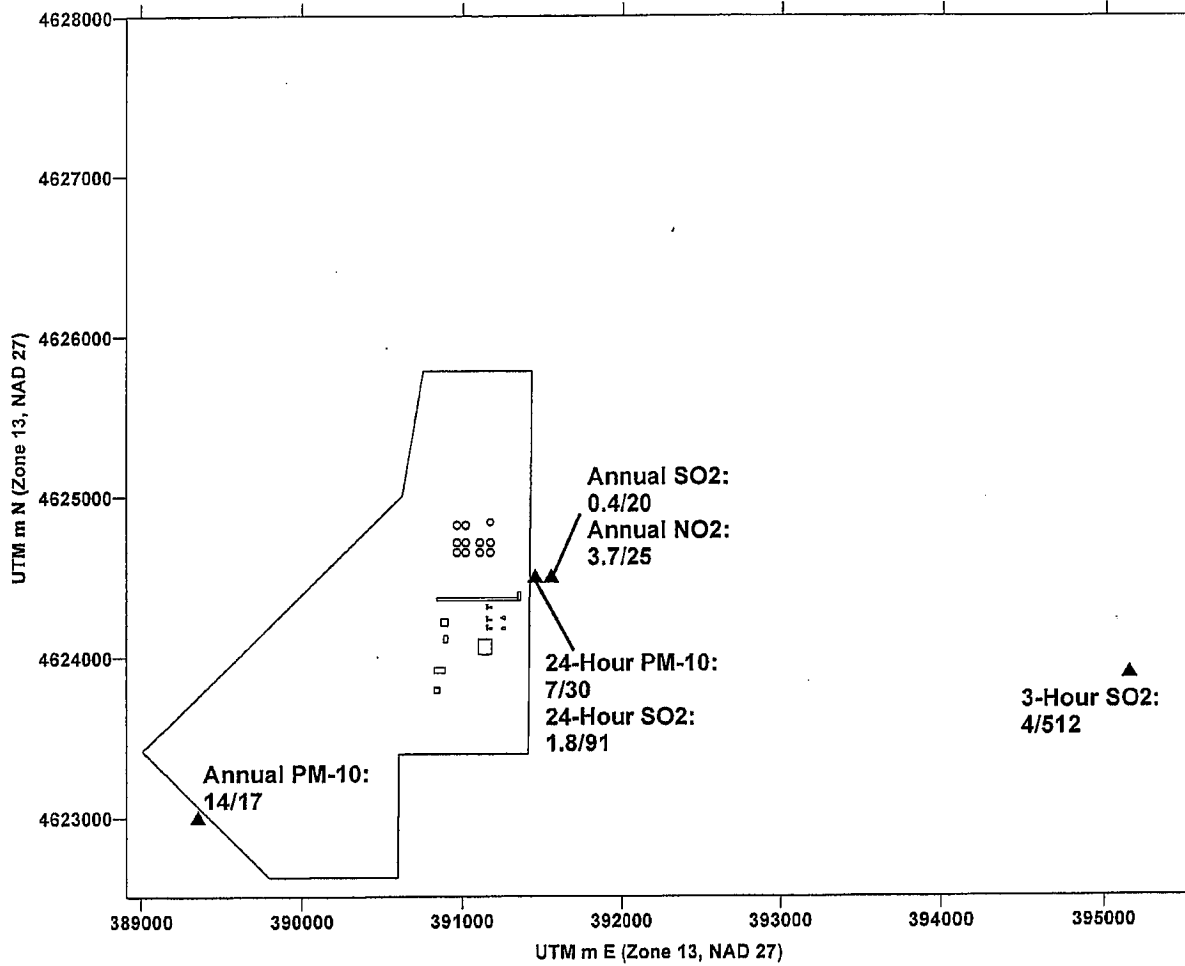

Figure 8 - Locations of Modeled Maximums (PSD Increments)



HAZARDOUS AIR POLLUTANTS ANALYSIS

The application included a risk assessment for Hazardous Air Pollutants (HAPs). Specifically, the applicant conducted a Tier 1 (screening level) inhalation risk assessment of HAPs to compare the predicted chronic carcinogenic, chronic non-carcinogenic, and acute non-carcinogenic risks to the respective reference levels. The analysis followed the facility-specific assessment guidance developed by the EPA, as described in the document *Air Toxics Risk Assessment Reference Library, Volume 2, Facility-Specific Assessment*. (http://www.epa.gov/ttn/fera/data/risk/vol_2/volume_2-april_2004.pdf). Dose-response values for use in screening level analyses for chronic and acute exposures were found on EPA's Air Toxics Website. (<http://www.epa.gov/ttn/atw/toxsource/summary.html>, Tables 1 and 2)

Human exposure via inhalation can be assessed by estimating the ambient air concentrations of HAPs. For this analysis, the AERMOD model was used to estimate the air concentrations of the predominant HAPs expected to be emitted from the proposed plant. The maximum annual concentration predicted for any receptor in the modeling grid was used to calculate chronic exposure, and the maximum predicted hourly concentrations were used to calculate acute exposure. Emissions of the predominant HAPs from the proposed plant are shown in a table below, and the risk calculations are described as follows.

Cancer Risk

Excess lifetime cancer risk is calculated using the following equation:

$$\text{Risk} = \text{EC}_L \times \text{IUR}$$

where:

Risk = excess lifetime cancer risk estimate (unitless)

EC_L = exposure concentration based on a lifetime of continuous inhalation exposure to an individual HAP ($\mu\text{g}/\text{m}^3$)

IUR = inhalation risk estimate for that HAP [$1/(\mu\text{g}/\text{m}^3)$]

Chronic Noncancer Hazard

Chronic noncancer hazard is estimated by dividing the exposure concentration by the reference concentration for a given HAP:

$$\text{HQ} = \text{EC}_C \div \text{RfC}$$

where:

HQ = chronic hazard quotient for an individual HAP (unitless)

EC_C = exposure concentration based on an estimate of continuous inhalation exposure to a HAP ($\mu\text{g}/\text{m}^3$)

RfC = noncancer reference concentration for a HAP ($\mu\text{g}/\text{m}^3$)

Table XXIII - Estimated HAP Emissions from the Proposed IGL Plant (grams per second)

Source ID	Short-Term Benzene (g/s)	Annual Benzene (g/s)	Short-Term Ethyl Benzene (g/s)	Annual Ethyl Benzene (g/s)	Short-Term Formaldehyde (g/s)	Annual Formaldehyde (g/s)	Short-Term Methanol (g/s)	Annual Methanol (g/s)	Short-Term n-Hexane (g/s)	Annual n-Hexane (g/s)	Short-Term Toluene (g/s)	Annual Toluene (g/s)	Short-Term Xylene (g/s)	Annual Xylene (g/s)
CTG1	1.20E-03	1.10E-03	3.17E-03	2.95E-03	7.00E-03	6.50E-03	0.00E+00	ST	0.00E+00	ST	1.30E-02	1.20E-02	6.30E-03	5.90E-03
CTG2	1.20E-03	1.10E-03	3.17E-03	2.95E-03	7.00E-03	6.50E-03	0.00E+00	ST	0.00E+00	ST	1.30E-02	1.20E-02	6.30E-03	5.90E-03
CTG3	1.20E-03	1.10E-03	3.17E-03	2.95E-03	7.00E-03	6.50E-03	0.00E+00	ST	0.00E+00	ST	1.30E-02	1.20E-02	6.30E-03	5.90E-03
GHEAT1	5.40E-06	3.00E-07	0.00E+00	ST	1.95E-04	1.11E-05	0.00E+00	ST	4.67E-03	2.66E-04	8.80E-06	5.00E-07	0.00E+00	ST
GHEAT2	5.40E-06	3.00E-07	0.00E+00	ST	1.95E-04	1.11E-05	0.00E+00	ST	4.67E-03	2.66E-04	8.80E-06	5.00E-07	0.00E+00	ST
GHEAT3	5.40E-06	3.00E-07	0.00E+00	ST	1.95E-04	1.11E-05	0.00E+00	ST	4.67E-03	2.66E-04	8.80E-06	5.00E-07	0.00E+00	ST
GHEAT4	5.40E-06	3.00E-07	0.00E+00	ST	1.95E-04	1.11E-05	0.00E+00	ST	4.67E-03	2.66E-04	8.80E-06	5.00E-07	0.00E+00	ST
GHEAT5	5.40E-06	3.00E-07	0.00E+00	ST	1.95E-04	1.11E-05	0.00E+00	ST	4.67E-03	2.66E-04	8.80E-06	5.00E-07	0.00E+00	ST
BSG1	1.08E-03	4.44E-05	0.00E+00	ST	1.30E-01	5.33E-03	0.00E+00	ST	2.73E-04	1.12E-05	1.00E-03	4.10E-05	4.50E-04	1.86E-05
BSG2	1.08E-03	4.44E-05	0.00E+00	ST	1.30E-01	5.33E-03	0.00E+00	ST	2.73E-04	1.12E-05	1.00E-03	4.10E-05	4.50E-04	1.86E-05
BSG3	1.08E-03	4.44E-05	0.00E+00	ST	1.30E-01	5.33E-03	0.00E+00	ST	2.73E-04	1.12E-05	1.00E-03	4.10E-05	4.50E-04	1.86E-05
FIREPUMP	4.50E-04	2.60E-05	0.00E+00	ST	5.70E-04	3.27E-05	0.00E+00	ST	0.00E+00	ST	2.00E-04	1.10E-05	1.28E-04	8.00E-06
AB	1.70E-05	ST	0.00E+00	ST	6.10E-04	ST	0.00E+00	ST	1.47E-02	ST	2.80E-05	ST	0.00E+00	ST
REGH	5.60E-06	ST	0.00E+00	ST	2.00E-04	ST	0.00E+00	ST	4.80E-03	ST	9.00E-06	ST	0.00E+00	ST
REAH	3.20E-06	ST	0.00E+00	ST	1.15E-04	ST	0.00E+00	ST	2.77E-03	ST	5.20E-06	ST	0.00E+00	ST
HGT	6.00E-07	ST	0.00E+00	ST	2.10E-05	ST	0.00E+00	ST	5.00E-04	ST	9.00E-07	ST	0.00E+00	ST
T_A	1.38E-03	ST	9.90E-05	ST	0.00E+00	ST	6.24E-03	ST	1.30E-03	ST	1.50E-03	ST	4.20E-04	ST
T_B	1.38E-03	ST	9.90E-05	ST	0.00E+00	ST	6.24E-03	ST	1.30E-03	ST	1.50E-03	ST	4.20E-04	ST
T_C	1.38E-03	ST	9.90E-05	ST	0.00E+00	ST	6.24E-03	ST	1.30E-03	ST	1.50E-03	ST	4.20E-04	ST
T_D	1.38E-03	ST	9.90E-05	ST	0.00E+00	ST	6.24E-03	ST	1.30E-03	ST	1.50E-03	ST	4.20E-04	ST
T_E	1.38E-03	ST	9.90E-05	ST	0.00E+00	ST	6.24E-03	ST	1.30E-03	ST	1.50E-03	ST	4.20E-04	ST
T_F	1.38E-03	ST	9.90E-05	ST	0.00E+00	ST	6.24E-03	ST	1.30E-03	ST	1.50E-03	ST	4.20E-04	ST
T_G	1.38E-03	ST	9.90E-05	ST	0.00E+00	ST	6.24E-03	ST	1.30E-03	ST	1.50E-03	ST	4.20E-04	ST
T_H	1.38E-03	ST	9.90E-05	ST	0.00E+00	ST	6.24E-03	ST	1.30E-03	ST	1.50E-03	ST	4.20E-04	ST
T_I	1.38E-03	ST	9.90E-05	ST	0.00E+00	ST	6.24E-03	ST	1.30E-03	ST	1.50E-03	ST	4.20E-04	ST
T_J	1.38E-03	ST	9.90E-05	ST	0.00E+00	ST	6.24E-03	ST	1.30E-03	ST	1.50E-03	ST	4.20E-04	ST
T_K	1.38E-03	ST	9.90E-05	ST	0.00E+00	ST	6.24E-03	ST	1.30E-03	ST	1.50E-03	ST	4.20E-04	ST
V1	2.27E-01	ST	0.00E+00	ST	0.00E+00	ST	2.27E-01	ST	0.00E+00	ST	0.00E+00	ST	0.00E+00	ST

ST = Annual emission rate same as short-term rate

Acute Noncancer Hazard

The acute noncancer hazard quotient (HQ_A) is estimated by dividing the exposure concentration by the acute dose-response value for the HAP:

$$HQ_A = EC_{ST} \div AV$$

where:

HQ_A = acute hazard quotient for an individual HAP (unitless)

EC_{ST} = exposure point concentration based on an estimate of short-term inhalation exposure to a HAP (µg/m³)

AV = acute dose-response value for a HAP (µg/m³)

Storage tanks at the proposed plant that will hold gasoline, methanol, and heavy gasoline were modeled as volume sources. Total tank emissions for each HAP were divided equally among the eleven tank volume sources, and each tank volume source release height was set to the tank's height. A ground-based volume source located in the synthesis process areas of the plant was used to represent equipment leaks. Model input parameters for the volume sources are presented in the table below.

Table XXIV Volume Source Release Parameters for IGL Plant							
Volume Sources	Description	UTM East (m)	UTM North (m)	Base Elev. (m)	Release Height (m)	Sigma Y (m)	Sigma Z (m)
T A	Gasoline Tank	390966	4624652	2128	14.63	10.63	2.32
T B	Gasoline Tank	391021	4624652	2129	14.63	10.63	2.32
T C	Gasoline Tank	391109	4624652	2123	14.63	10.63	2.32
T D	Gasoline Tank	391175	4624652	2118	14.63	10.63	2.32
T E	Gasoline Tank	390966	4624712	2126	14.63	10.63	2.32
T F	Gasoline Tank	391021	4624712	2127	14.63	10.63	2.32
T G	Gasoline Tank	391109	4624712	2127	14.63	10.63	2.32
T H	Gasoline Tank	391175	4624712	2120	14.63	10.63	2.32
T I	Methanol Tank	390966	4624822	2121	14.63	10.63	2.32
T J	Methanol Tank	391021	4624822	2118	14.63	10.63	2.32
T K	Heavy Gas Tank	391174	4624840	2117	14.63	9.21	2.32
V1	Equipment Leaks	391224	4624458	2117	2	61.12	4.65

UTM Coordinates expressed in NAD 27, Zone 13

Results of the Tier 1 inhalation risk assessment are summarized in the table below.

Table XXV - Tier 1 Inhalation Risk Assessment Results			
Parameter/HAP	Factors/Risk		
	EC _L (µg/m ³)	IUR [1/(µg/m ³)]	Risk
Cancer Risk			
Benzene	11.3	0.0000078	8.81E-05
Ethyl benzene	--	--	--
Formaldehyde	0.047	5.50E-09	2.59E-10
Methanol	--	--	--
Hexane	--	--	--
Toluene	--	--	--
Xylene	--	--	--
Chronic Noncancer Risk	EC _C (µg/m ³)	RfC (µg/m ³)	HQ
Benzene	11.3	30	0.38
Ethyl benzene	0.007	1,000	0.00001
Formaldehyde	0.047	9.8	0.0048
Methanol	11.3	4,000	0.003
Hexane	0.125	700	0.00018
Toluene	0.105	5,000	0.00002
Xylene	0.030	100	0.00030
Acute Noncancer Risk	EC _{ST} (µg/m ³)	AV (µg/m ³)	HQ _A
Benzene	255	1,300	0.20
Ethyl benzene	0.243	350,000	0.000001
Formaldehyde	75.3	94	0.80
Methanol	254	28,000	0.01
Hexane	3.50	390,000	0.00001
Toluene	3.70	37,000	0.0001
Xylene	1.03	22,000	0.00005

Notes:

- 1) "--" indicates that no dose-response value is listed in the EPA dose-response tables for this HAP
- 2) AV for all listed HAP are based on most conservative (lowest) value for 1-hour exposure listed in the EPA Acute Dose-Response Value table

The maximum modeled 1-hour (acute) and annual (chronic) exposures were located very near the proposed IGL Plant, as shown in the figure below.

Estimated increased cancer risk was highest for benzene. An isopleths plot that shows the extent of the one per million increased cancer risk is shown in the figure below.

The Tier 1 inhalation risk assessment is provided to inform the general public of the associated risk from the operation of the proposed project. This analysis is very conservative, given that it is based on the assumption that a population will be continuously exposed to the maximum model-predicted concentrations of each HAP of interest.

Figure 9 - Locations of Modeled Maximum 1-Hour or Annual HAP Exposures

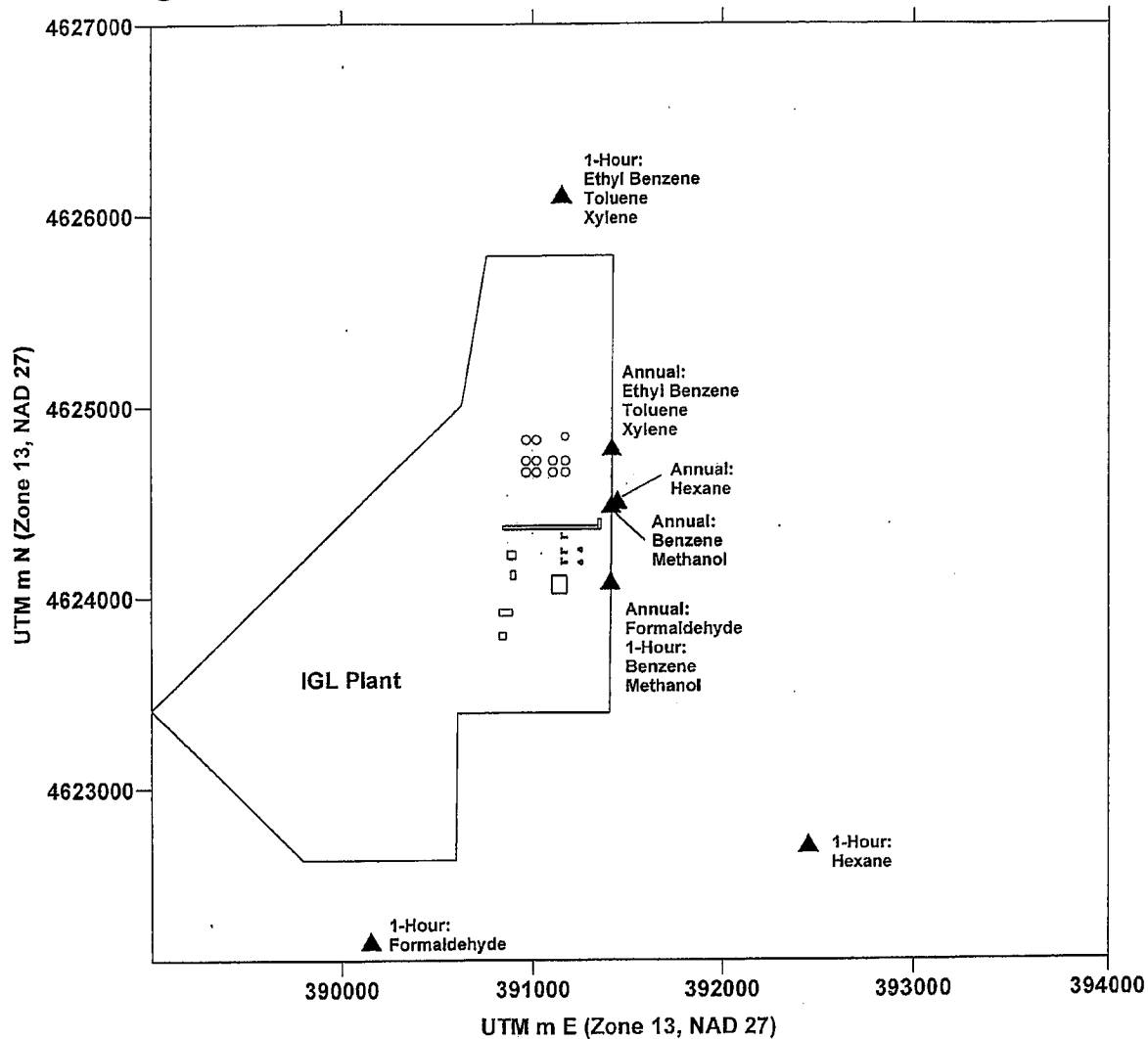
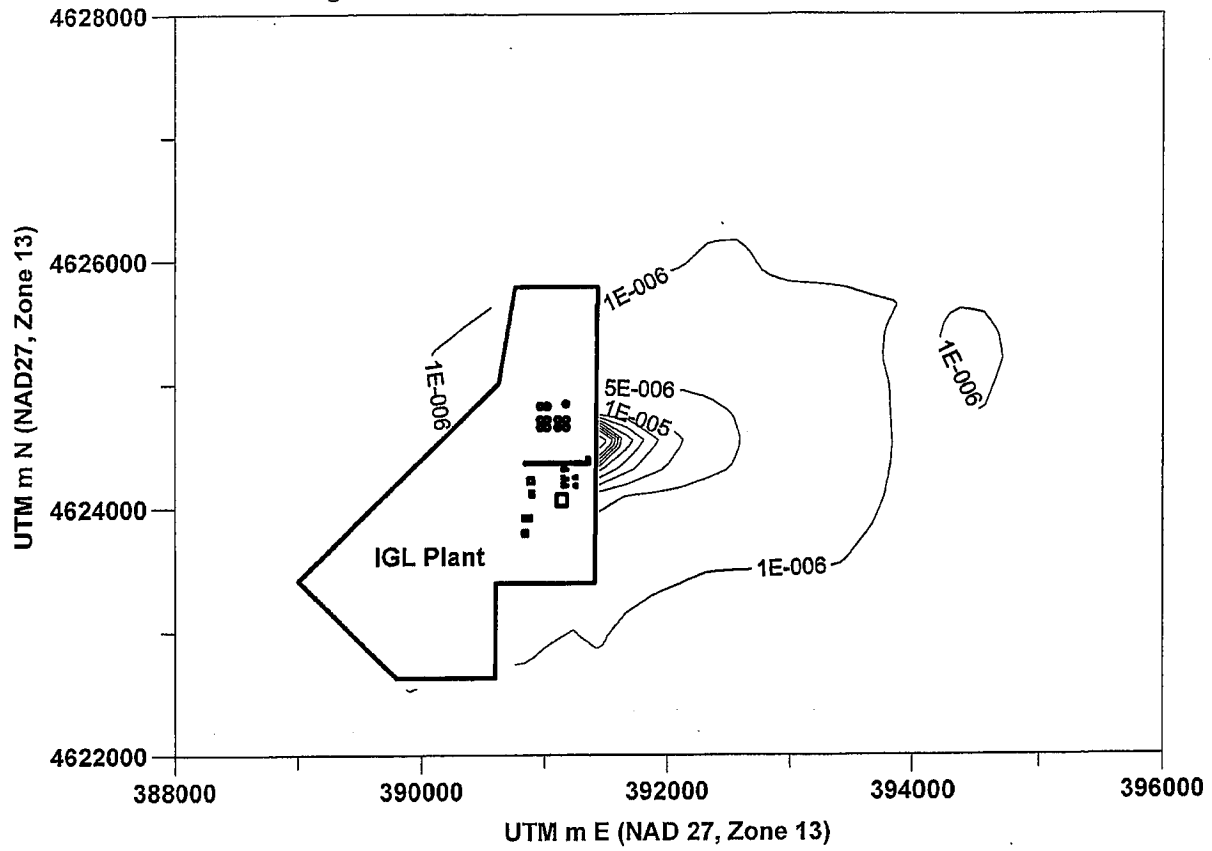

Figure 10 - Modeled Increased Cancer Risk for Benzene



ADDITIONAL IMPACTS ANALYSIS

As required by WAQSR Chapter 6, Section 4 (b)(i)(B), the applicant must assess impacts to Air Quality Related Values (AQRVs), to include:

- Growth Impacts
- Impact to Soils and Vegetation
- Impacts to Visibility

Growth Impacts

During normal operations, the plant is expected to employ 300 to 400 people with various trades. Many of these trades are commonly found in the coal mining industry. These employees are expected to live in the existing nearby communities, such as Elk Mountain, Medicine Bow, Hanna, Saratoga, Rawlins, and Laramie.

Carbon County has historically been a coal mining area with mining activity from the turn of the century through 2005. The commercial support industries are already in place in Hanna and along the I-80 corridor, and the operation of the plant is not expected to produce significant air quality impacts from growth.

Impacts to Soils and Vegetation

Data from the U.S. Department of Agriculture (USDA) Natural Resources Conservation Service (NRCS) indicates that only one percent of surveyed land in Carbon County produces alfalfa or hay without using irrigation. The commercial productivity of the lands around the immediate Medicine Bow area is very low, and soils in the region generally do not have significant commercial or recreational value.

The secondary NAAQS and WAAQS have been established to protect public health and welfare from any adverse effects of criteria pollutants, including protection from damage to crops and vegetation. The modeling analyses for NO₂, SO₂, and PM₁₀ indicate that the ambient air quality impacts are below the respective secondary NAAQS/WAAQS. Based on the modeling analyses and literature review submitted in the application, it is expected that the operation of the proposed plant will not adversely impact soils and vegetation in the near vicinity.

Impacts to Visibility

Impacts resulting from operation of the proposed plant to visibility were assessed for the nearest Class I areas, as described in the following section (Far-Field Modeling).

FAR-FIELD MODELING ANALYSIS

Congress has designated particular areas for the highest level of air-quality protection. These areas, known as “Class I” areas, include larger national parks and wilderness areas that were in existence in 1977. A total of 158 areas were classified by Congress as “mandatory” (Federal) Class I areas that cannot be redesignated to a level with a lesser degree of protection. The Federal Land Managers (FLMs) are given, through the PSD title of the Clean Air Act, a role in the protection of Class I areas from air quality impairment due to man-made air pollution.

A workgroup consisting of representatives from the three FLMs that manage the 158 Federal Class I areas has developed a guidance document for assessing the impact of PSD sources on those Class I areas. This workgroup, called the *Federal Land Managers' Air Quality Related Values Work Group* (FLAG), released their *FLAG Phase I Report* in December of 2000. The analyses for the project described here made use of the recommended procedures from the FLAG report.

The MBFP IGL Plant would be located within 300 kilometers (km) of several mandatory Class I areas, including Mount Zirkel and Rawah Wilderness Areas (WA) in Colorado and Bridger WA in Wyoming. Savage Run WA is an area which has been designated Class I by the State of Wyoming. Figure 11 shows the relative locations of Class I areas within 300 km of the proposed plant. The applicant submitted a Class I area significant impact analysis, as well as analyses of the impacts to visibility and nitrogen/sulfur deposition from the proposed project at the Class I areas shown in Figure 11.

Model Justification

Predicted impacts from the proposed project were determined with the EPA’s CALPUFF modeling system, which is the EPA-preferred model for long-range transport. As described in the EPA Guideline on Air Quality Models (GAQM, Appendix W of 40 CFR Part 51), long-range transport is defined as source-receptor distances of 50 km to several hundred km (“far-field”). Because all modeled areas are located more than 50 km from the proposed sources, the CALPUFF modeling system was appropriate for use.

The CALPUFF modeling system consists of a meteorological data pre-processor (CALMET), an air dispersion model (CALPUFF), and various post-processor programs (POSTUTIL, CALPOST, etc.). The CALPUFF model was developed as a non-steady-state air quality modeling system for assessing the effects of time- and space-varying meteorological conditions on pollutant transport, transformation, and removal.

Updated versions of the CALPUFF modeling system are made available on the website of the model developers, the Atmospheric Studies Group (ASG) of TRC Companies, Inc. For the project described here, the current “Official EPA-Approved” version of the system was used. Version numbers and release dates of the primary models included in the EPA-Approved version of the modeling system that was used for this project are listed below:

- CALMET – Version 5.8 (June 23, 2007)
- CALPUFF – Version 5.8 (June 23, 2007)
- CALPOST – Version 5.6394 (June 22, 2007)
- POSTUTIL – Version 1.56 (June 27, 2007)

Figure 11 – Location of Proposed Project vs. Class I Areas

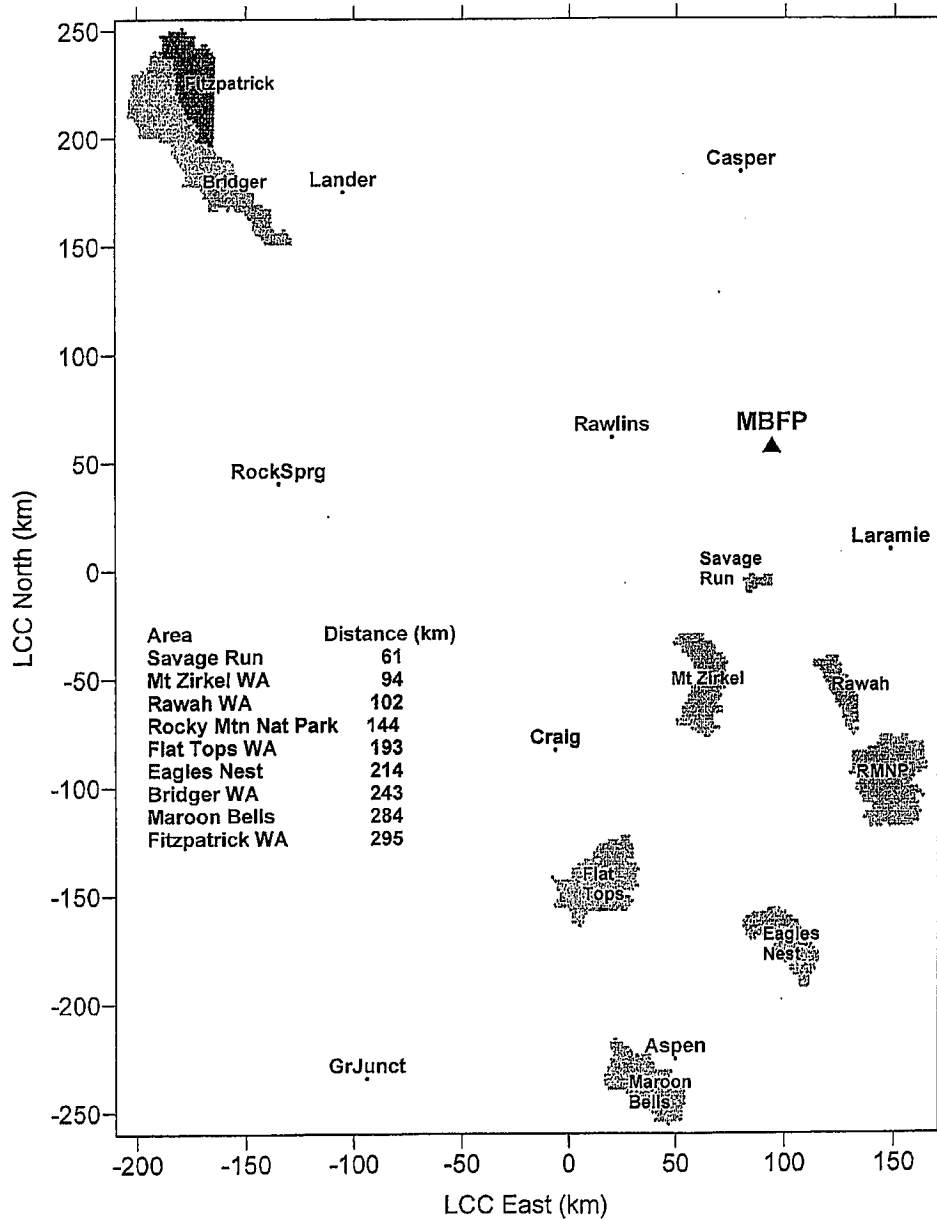

Short descriptions of the various models and pre- and post-processors that comprise the CALPUFF modeling system are provided below.

CALMET Model

CALMET is a diagnostic wind model that develops hourly wind and temperature fields in a three-dimensional, gridded modeling domain. Meteorological inputs to CALMET can include surface and upper-air observations from multiple meteorological monitoring stations. Additionally, the CALMET model can utilize gridded analysis fields from various mesoscale models such as MM5 to better represent regional wind flows and slope/valley circulations. Associated two-dimensional fields such as land use and surface roughness are included in the input to the CALMET model. The CALMET model allows the user to “weight” various terrain influence parameters in the vertical and horizontal directions by defining the radius of influence for surface and upper-air stations.

CALPUFF Model

CALPUFF is a multi-layer, non-steady state, Lagrangian puff dispersion model. CALPUFF can use the three-dimensional wind fields developed by the CALMET model (refined mode), or data from a single surface and upper-air station in a format consistent with the meteorological file used to drive the ISC steady-state dispersion model (screening mode). All far-field modeling assessments, including the significance analysis and acid deposition and visibility modeling analyses, were completed using the CALPUFF model in a refined mode.

POSTUTIL Model

POSTUTIL is a post-processing program that processes CALPUFF concentrations and wet/dry flux files.

The POSTUTIL model operates on one or more output data files from CALPUFF to sum, scale, repartition, and/or compute species derived from those that are modeled, and outputs selected species to a file for further post-processing. For this application, POSTUTIL was used to post-process the predicted hourly wet and dry deposition fluxes from the proposed project to derive total nitrogen (N) and sulfur (S) deposition

CALPOST Model

CALPOST is a post-processing program that is designed to read the CALPUFF or POSTUTIL binary-formatted output files, and produce time-averaged concentrations and deposition fluxes. In addition to using CALPOST to post-process the deposition fluxes of total nitrogen (N) and total sulfur (S), the applicant used CALPOST to determine the significant impact (criteria pollutant) and visibility impacts from the proposed project.

Modeling Domain and Map Projection

Due to the size of the modeling domain, the curvature of the earth must be taken into account when calculating distances. To account for the earth's curvature in the modeling domain, the grid cells were identified using a Lambert Conformal Conic (LCC) map projection. The locations of sources, meteorological stations, and modeling receptors used in the CALMET/CALPUFF analyses were converted to a LCC projection. The applicant used a CALMET/CALPUFF modeling domain and map projection that were developed through guidance from the Division and the FLM. Key parameters for the map projection are listed below:

- Latitude of Projection Origin: 41.25°N
- Longitude of Projection Origin: 107.44°W
- Standard Parallel 1: 39.57°N
- Standard Parallel 2: 42.94°N

Discrete receptors for CALPUFF modeling of Class I areas were taken from a database developed by the National Park Service (NPS). Coordinates for these receptors, expressed in latitude/longitude in the NPS database, were converted to LCC coordinates using the map projection parameters listed above. Terrain elevations for the discrete receptors were also provided in the NPS database. Savage Run was represented by the applicant with 30 receptors placed at a spacing of 1-2 km.

Geophysical Data

Land use and terrain data for the modeling domain were obtained from the USGS, and input to the MAKEGEO pre-processor to prepare the geophysical data needed by CALMET. Land use data were obtained in Composite Theme Grid (CTG) format, and the Level I USGS land use categories were mapped into the 14 primary CALMET land use categories. Surface properties such as albedo, Bowen ratio, roughness length, and leaf area index were computed for each grid cell in the domain from the land use values. A value that is representative of “shrub and brush rangeland” (the predominant land use category for the domain) was used for the IMISS parameter, which is used to substitute for missing USGS land use data. The terrain and land use patterns that were used to represent the modeling domain are depicted in the figures below.

Figure 12 – Land Use for CALMET/CALPUFF Domain

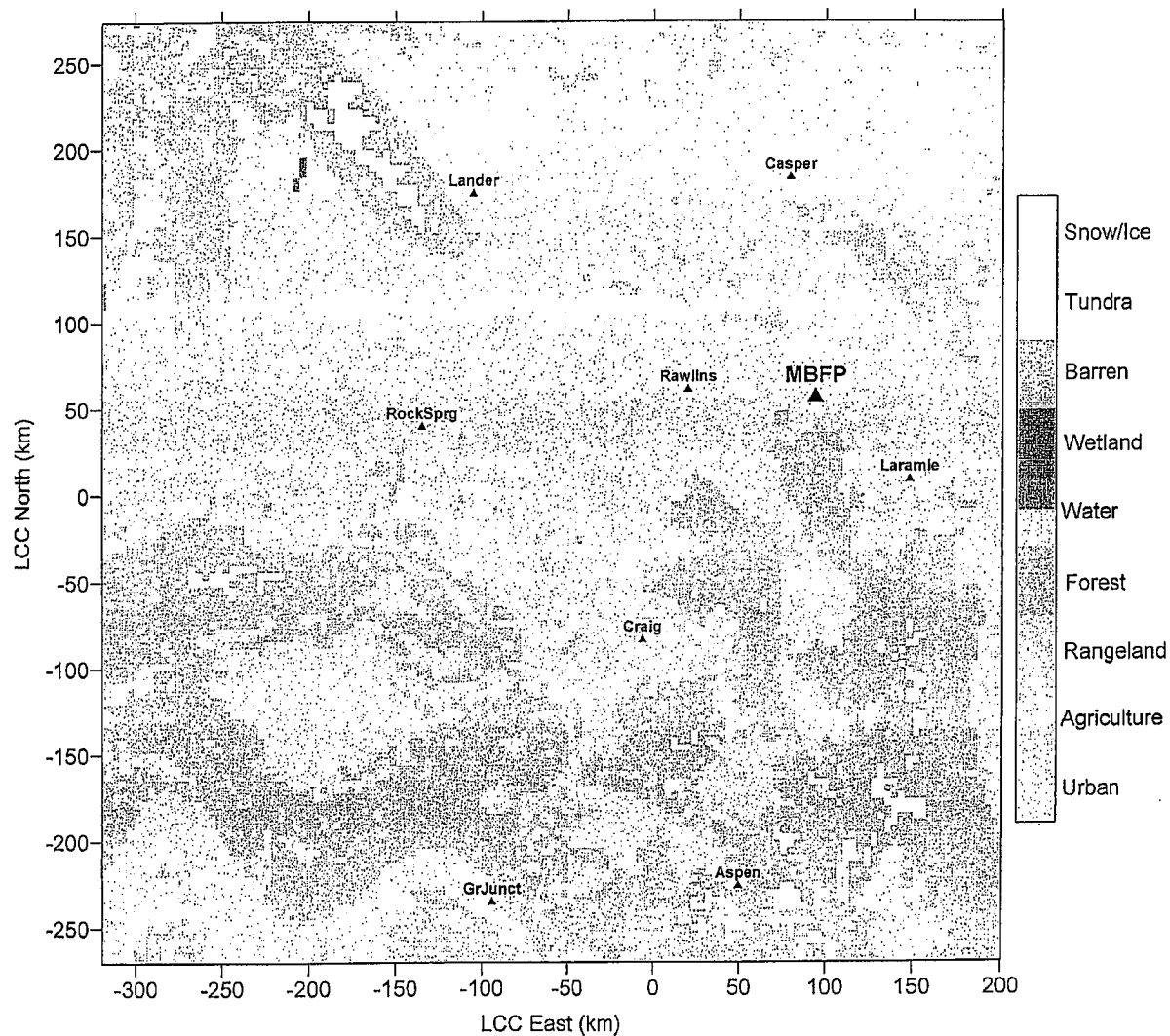
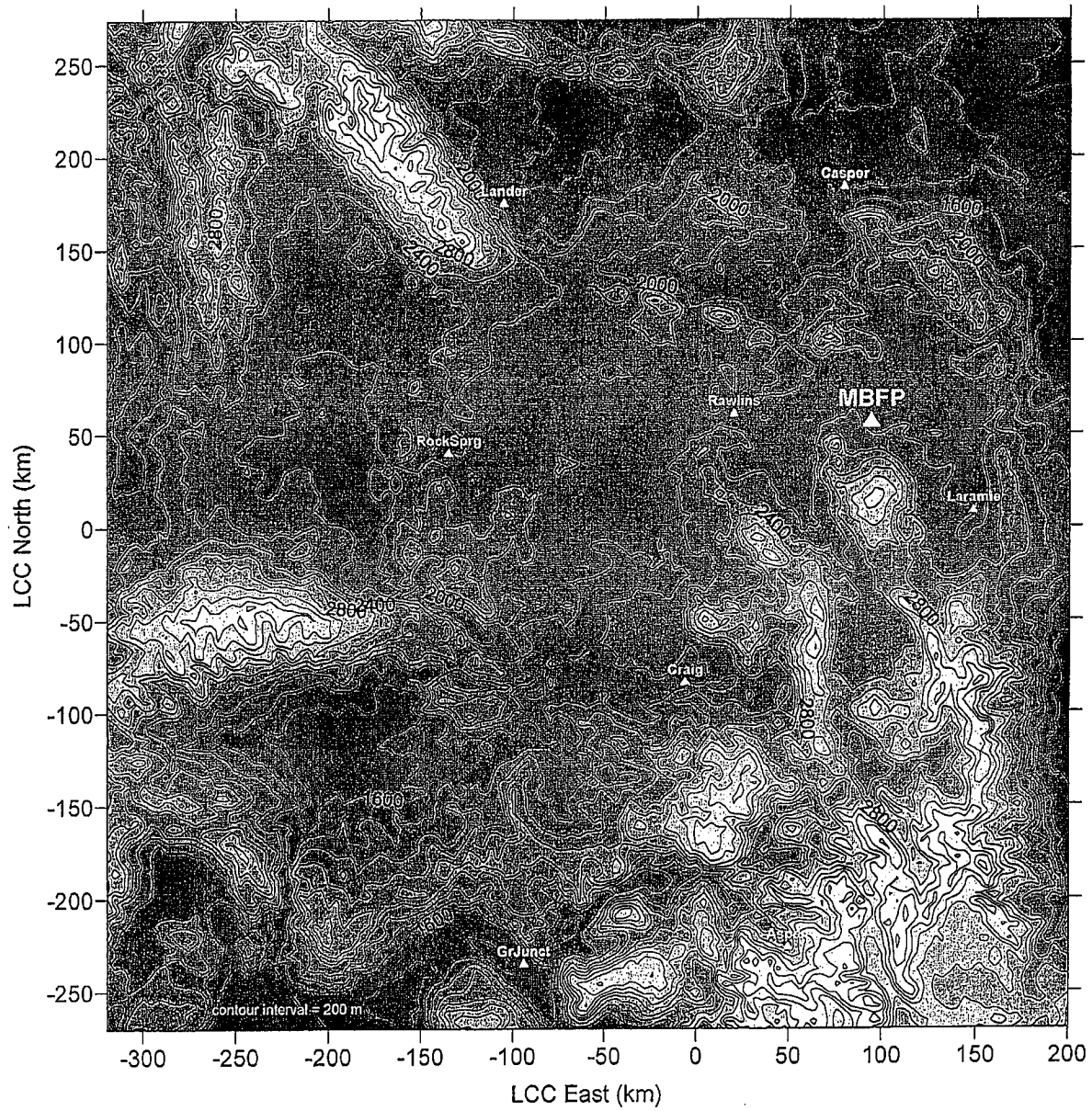

Figure 13 – Terrain for the CALMET/CALPUFF Domain



Meteorological Data

Three years of meteorological data (2001, 2002, and 2003) were used as input to CALPUFF. The modeling domain consisted of 131 (east-west) by 137 (north-south) 4 km x 4 km grid cells covering the source region, as well as the Class I areas of interest with a sufficient buffer zone for potential recirculation or flow reversal effects. The horizontal extent of the domain was 524 km x 548 km.

Based on EPA guidance on far-field CALPUFF modeling that is contained in the GAQM, the use of at least three years of prognostic mesoscale meteorological data is encouraged. For this analysis, the applicant obtained three years of mesoscale (MM5) data for the years 2001 through 2003 from the Colorado Department of Public Health and Environment (CDPHE). These data, with 36-km resolution, were developed for the Western Regional Air Partnership (WRAP) and were used by the CDPHE for Best Available Retrofit Technology (BART) modeling.

Hourly surface and precipitation data and twice-daily upper-air soundings for incorporation into the CALMET windfields were provided to the applicant by the Division. These data had been developed for previous CALMET analyses that were approved by the Division. Figure 14 shows the modeling domain and the locations of the observational data within the modeling domain that were input to CALMET.

The technical options within CALMET were generally set to default values, but several of the input settings for CALMET are left to the model user to define so that the windfield can be tailored to the particular area that is being modeled. Several of the key settings that were used for the windfields are listed in the table below.

The geophysical, MM5, surface, upper-air, and precipitation data were processed and input to CALMET to generate the CALMET.DAT files that are needed to drive the CALPUFF model. The resulting CALMET.DAT files include (among other parameters), gridded fields of U-V-W wind components, mixing heights, stability categories, micro-meteorological parameters, and precipitation data.

CALPUFF Inputs

Stack parameters and emissions for the sources modeled within CALPUFF for the proposed facility are shown in the tables below. These sources and emissions were used to model the significant impact (criteria pollutant), visibility impacts, and deposition impacts.

Several sources proposed for the facility were not included in the CALPUFF modeling. The HP and LP flares were not included because they would only be significant sources of visibility-reducing or criteria pollutants during cold starts or malfunctions. The same applies to the Gasifier Preheaters, Black-Start Generators, CO₂ Vent Stack, and Firewater Pump. Start-up conditions were conservatively considered for the turbines by assuming that one of the three units was in start-up mode for six hours during each 24-hour period. Short-term emissions were used to model long-term impacts, which results in a conservative estimate of annual parameters such as deposition.

The speciation of particulate matter followed the NPS recommendations for natural gas fired combustion turbines, as found on their Nature & Science website. Based on the NPS scheme, emissions were input to CALPUFF for elemental carbon (EC), organic carbon (SOA), and sulfates.

Figure 14 – Observations Input to CALMET

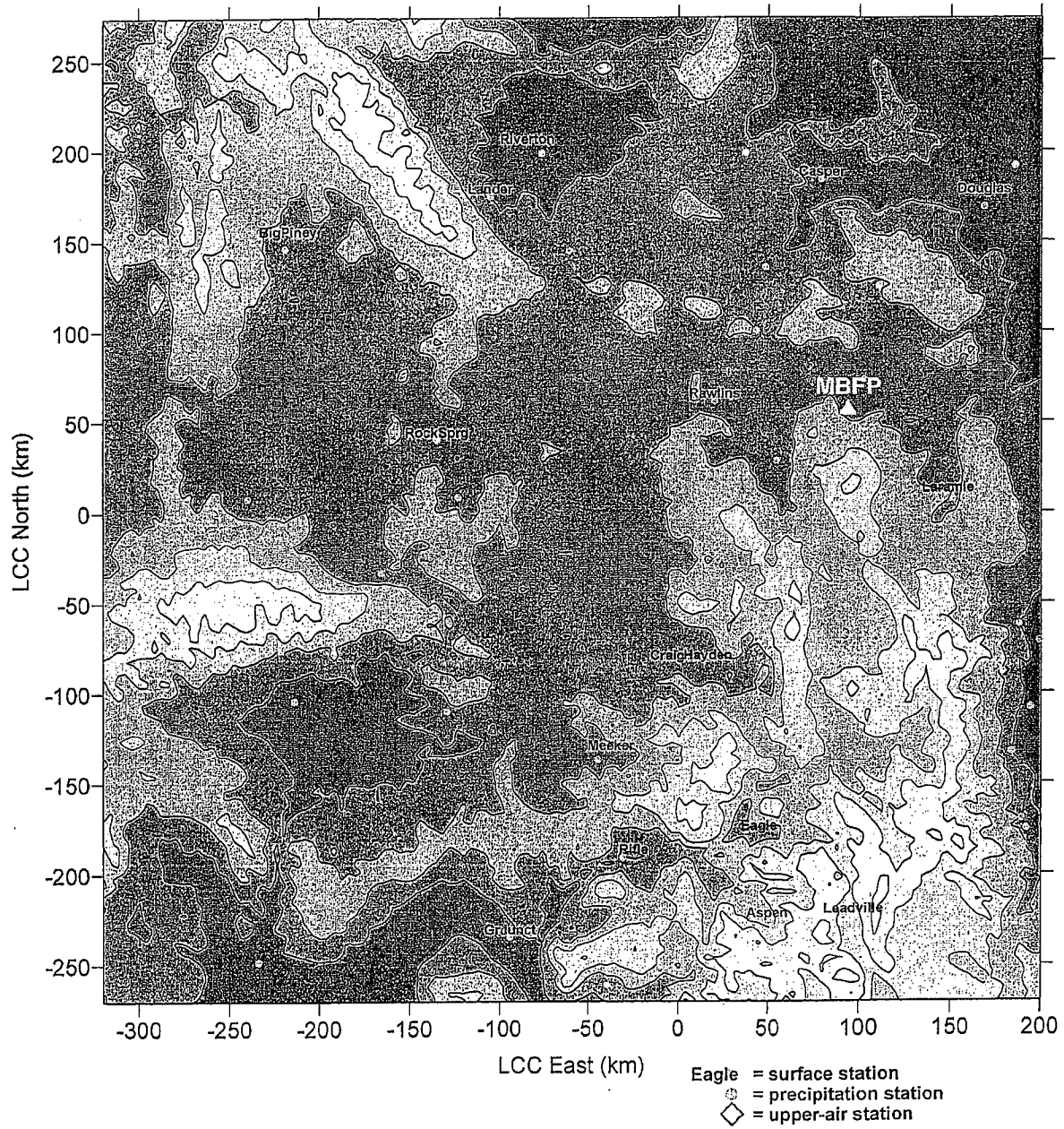

Table XXVI Key CALMET Settings		
Parameter	Setting	Description
NOOBS	0	Use surface and upper-air stations
RMIN2	-1	Extrapolate all surface stations
I PROG	14	Use MM5 as initial windfield
RMAX1	30	Maximum radius of influence for surface observations (km)
RMAX2	50	Maximum radius of influence for upper-air observations (km)
TERRAD	15	Radius of influence of terrain features (km)
R1	5	Distance at which surface observation and MM5 data equally weighted (km)
R2	25	Distance at which upper-air observation and MM5 data equally weighted (km)
NZ	10	Number of vertical layers (0, 20, 40, 100, 200, 350, 500, 750, 1000, 2000, 3500 m)
ZIMAX	3500	Maximum overland mixing height (m)

Table XXVII - Stack Parameters for Sources Modeled in CALPUFF

Source ID	Source Description	UTM East (m)	UTM North (m)	LCC E (km)	LCC N (km)	Base Elev. (m)	Stack Height (m)	Temp. (K)	Exit Velocity (m/s)	Stack Diam. (m)
CTG1	Turbine and HRSG Train 1	391190	4624310	94.011	57.795	2121	45.73	366.5	7.65	5.79
CTG2	Turbine and HRSG Train 2	391190	4624232	94.014	57.717	2121	45.73	366.5	7.65	5.79
CTG3	Turbine and HRSG Train 3	391190	4624180	94.015	57.665	2120	45.73	366.5	7.65	5.79
AB	Auxiliary Boiler	391086	4624006	93.916	57.488	2125	15.24	422.1	1.6	0.91
REGH	Catalyst Regenerator	391329	4624468	94.146	57.957	2114	15.24	422.1	1.6	0.91
REAH	Reactivation Heater	391330	4624486	94.146	57.975	2113	15.24	422.1	1.6	0.91
HGT	HGT Reactor Charge Heater	391329	4624448	94.146	57.937	2114	15.24	422.1	1.6	0.91

Table XXVIII - Base Emissions for IGL Sources (lb/hr)

Source ID	Source Description	SO ₂	NO _x	Total PM ₁₀	SO ₄	Total SOA
CTG1	Turbine and HRSG Train 1	2.67	18.61	10.0	1.34	6.2
CTG2	Turbine and HRSG Train 2	2.67	18.61	10.0	1.34	6.2
CTG3	Turbine and HRSG Train 3	2.67	33.35	10.0	1.34	6.2
AB	Auxiliary Boiler	0.04	3.24	0.49	0.02	0.35
REGH	Catalyst Regenerator	0.01	1.06	0.16	0.01	0.11
REAH	Reactivation Heater	0.01	0.61	0.09	0.004	0.06
HGT	HGT Reactor Charge Heater	0.001	0.11	0.02	0.001	0.01

Notes:

24-hour NO_x emissions for turbines (CTG1-3) are based on normal operation for two turbines and 18 hours under normal conditions + 6-hours of cold start-up (77.56 lb/hr) for one turbine (CTG3).

Table XXIX - Emission Rates Input to CALPUFF (lb/hr)

Source ID	Source Description	SO ₂	SO ₄	NO _x	Total PM ₁₀ - INCPM	PM0005	PM0010	PM0015	PM0020	PM0025	PM0100	EC
CTG1	Turbine and HRSG Train 1	1.78	1.34	18.61	10.00	0.92	1.54	1.42	0.92	0.68	0.68	2.50
CTG2	Turbine and HRSG Train 2	1.78	1.34	18.61	10.00	0.92	1.54	1.42	0.92	0.68	0.68	2.50
CTG3	Turbine and HRSG Train 3	1.78	1.34	33.35	10.00	0.92	1.54	1.42	0.92	0.68	0.68	2.50
AB	Auxiliary Boiler	0.03	0.02	3.24	0.49	0.05	0.09	0.08	0.05	0.04	0.04	0.12
REGH	Catalyst Regenerator	0.01	0.01	1.06	0.16	0.02	0.03	0.03	0.02	0.01	0.01	0.04
REAH	Reactivation Heater	0.005	0.004	0.61	0.09	0.01	0.02	0.01	0.01	0.01	0.01	0.02
HGT	HGT Reactor Charge Heater	0.001	0.001	0.11	0.02	0.002	0.004	0.003	0.002	0.002	0.002	0.01

Notes:

NPS Particulate Matter Speciation - Natural Gas Fired Combustion Turbines
 (<http://www.nature.nps.gov/air/Permits/ect/GasFiredCT.cfm>)

1. 25% of PM assumed to be filterable = elemental carbon (EC)
2. 1/3 of SO₂, adjusted for MW (96/64) = SO₄; 2/3 of initial SO₂ is input as SO₂
3. Total secondary organic aerosol (SOA) = condensible (75% of total PM₁₀) minus SO₄
4. SOA split: PM0005 (15%), PM0010 (25%), PM0015 (23%), PM0020 (15%), PM0025 (11%), and PM0100 (11%)

Hourly ozone data was input to CALPUFF to allow for chemical transformations. The ozone data were taken from the following sites:

Wyoming

- Centennial
- Pinedale

Colorado

- Gothic
- Rocky Mountain National Park
- Highland Reservoir
- U.S. Air Force Academy
- Fort Collins

For periods of missing ozone data, the model relied on a default value of 44 parts per billion (ppb). A constant, domain-wide background ammonia value of 2.0 ppb was input to the model.

Class I Area Significant Impact Analysis

Guidance published in the Federal Register (Vol. 61, No. 142, July 1996) by the U.S. EPA established a method to determine whether a new source has an insignificant ambient impact on a Class I area. This guidance introduced a set of Class I area Significant Impact Levels (SILs) to be used as the metric for assessing the ambient impacts at Class I areas from potentially insignificant sources. The Class I SILs are based on a percentage of the Class I increments for each respective averaging period. In the proposed rules, a new source or proposed modification which can be shown, using air quality models, to have ambient impacts below the Class I SILs for a given pollutant and averaging period would not be required to conduct a cumulative Class I increment consumption analysis for that pollutant.

The proposed EPA Class I SILs for NO₂, SO₂, and PM₁₀ used in this analysis are provided below.

Table XXX		
EPA-Proposed Class I Area Modeling Significance Levels		
Pollutant	Averaging Period	Class I Significant Impact Level (µg/m ³)
NO ₂	Annual	0.1
SO ₂	3-Hour	1.0
SO ₂	24-Hour	0.2
SO ₂	Annual	0.1
PM ₁₀	24-Hour	0.3
PM ₁₀	Annual	0.2

NO₂ = nitrogen dioxide
 PM₁₀ = particulate matter less than 10 microns
 SO₂ = sulfur dioxide

In the Class I area significance analysis, the Division's modeling demonstrated that maximum modeled concentrations from the proposed project were well below all respective Class I SILs for each pollutant at each Class I area that was analyzed, as shown in the table near the end of this section of the analysis. Emissions of nitrogen oxides (NO_x) were conservatively assumed to convert completely to nitrogen dioxide (NO₂) for comparison to the Class I SIL for NO₂.

Class I Area Visibility Analysis

The modeled change in visible light extinction (visibility) from the proposed facility was based on the CALPUFF-predicted concentrations of primary and secondary pollutants. Secondary pollutants in this case include nitrates and sulfates.

CALPOST Method 2 was used to arrive at results for the visibility analysis. CALPOST Method 2 uses hourly relative humidity values from the surface observations that are input to CALMET, and is the CALPOST method recommended by the FLM in the FLAG report. In CALPUFF and CALPOST, relative humidity data are used as a surrogate for cloud water and water vapor to account for the formation and hygroscopic growth of secondary particles. Specifically, the relative humidity data are used in CALPUFF visibility modeling in two ways: 1) In the CALPUFF chemical transformation module that forms sulfate and nitrate, and 2) to derive the relative humidity adjustment function [f(RH)] that is applied to ammonium sulfate and ammonium nitrate concentrations to estimate hygroscopic particle growth.

Background light extinction ($b_{ext,bkgd}$) is used to determine the percent light extinction due to the emission source in question. As prescribed in the FLAG report, the background must represent "natural background", i.e. background due only to natural aerosols in the atmosphere. Natural background is determined with this equation:

$$b_{ext,bkgd} = b_{hygroscopic} \times f(RH) + b_{NonHygroscopic} + Rayleigh$$

Values for $b_{hygroscopic}$, $b_{NonHygroscopic}$, and Rayleigh light scattering components are provided in Appendix 2.B of the FLAG Phase I report. The values for $b_{hygroscopic}$ (0.6 Mm⁻¹), $b_{NonHygroscopic}$ (4.5 Mm⁻¹), and Rayleigh scattering (10 Mm⁻¹) are identical for all Western Class I areas. The background extinction values are not provided for Savage Run WA, but it was assumed that the background extinction provided in the FLAG document for other Western Areas also applied to Savage Run.

The model-predicted visibility impacts were based on the maximum 24-hour average concentrations for the following pollutants that reduce visibility: sulfate, nitrate, organic carbon (SOA), and elemental carbon (EC). The nitrate and sulfate transformation rates were computed internally by the CALPUFF model using the MESOPUFF II chemistry scheme, which assumes that all nitrate and sulfate fully convert to ammonium sulfate [(NH₄)₂SO₄] and ammonium nitrate [(NH₄)NO₃]. The 24-hour light extinction ($b_{ext,source}$), expressed in inverse Megameters (Mm⁻¹) was determined by the CALPOST model using the following equation:

$$b_{ext,source} = [(1.375*SO_4 + 1.29*NO_3)*f(RH)]*3 + PMF*1.0 + PMC*0.6 + OC*4 + EC*10$$

Where:

1.375	=	ratio of molecular weights for ammonium sulfate to sulfate
SO ₄	=	modeled mass of sulfate
1.29	=	ratio of molecular weights for ammonium nitrate to nitrate
NO ₃	=	modeled mass of nitrate
f(RH)	=	relative humidity function
3	=	light scattering efficiency for nitrates and sulfates (m ² /gram)
1.0	=	light scattering efficiency for fine PM _{2.5} (m ² /gram)
0.6	=	light scattering efficiency for coarse PM ₁₀ -PM _{2.5} (m ² /gram)
4	=	light scattering efficiency for organic carbon (m ² /gram)
10	=	light scattering efficiency for elemental carbon (m ² /gram)

The 24-hour average source and background extinction, both expressed in Mm⁻¹, were used to estimate the corresponding 24-hour average change in light extinction by the following equation:

$$\Delta b_{ext} \% = (b_{ext,source} / b_{ext,bkgd}) * 100$$

Where: $\Delta b_{ext} \%$ is the incremental change in visibility, expressed in percent (%)

Based on the CALPUFF modeling analysis using 2001-2003 meteorology and using CALPOST Method 2, the results indicate that there are zero days with a modeled change in visibility of 5% or more at any Class I area, as shown in the summary table below.

Class I Area Acid Deposition Analysis

Emissions of nitrogen- and sulfur-based pollutants have the potential to convert to nitrate and sulfate compounds in the atmosphere, and can be deposited as nitric and sulfuric acids into sensitive lakes and other water bodies. This effect can increase the acidity of the water bodies. All of the effects of acid deposition are not well known, but large amounts of acidic deposition can significantly affect soils, vegetation, lake chemistry and the aquatic habitats of sensitive species.

The CALPUFF model was used to estimate the wet and dry deposition fluxes of nitrate and sulfate species from the proposed project emissions, and those impacts were compared to threshold sensitivity deposition values provided by the FLM. Total nitrogen (N) deposition rates were calculated based on the wet and dry deposition rates of nitrogen oxides (NO_x), nitric acid (HNO₃), ammonium nitrate [(NH₄)NO₃], and ammonium sulfate [(NH₄)₂SO₄]. Total sulfur (S) deposition rates were calculated based on the wet and dry deposition rates of sulfur dioxide (SO₂) and sulfate (SO₄).

The model-predicted total S and total N deposition rates were compared to the Deposition Analysis Threshold (DAT) values for total S and total N, which are 0.005 kilograms per hectare per year (kg/ha/yr). These DAT values were established by the NPS and the U.S. Fish and Wildlife Service for the Western United States.

A summary of the maximum modeled annual total N and S impacts from all years of meteorology used in this analysis indicate that the model-predicted deposition rates were below the DAT of 0.005 kg/hectare/year for all Class I areas of interest for all three years that were modeled. The modeled results of the deposition analysis are presented in the summary table below.

Table XXXI - Results of CALPUFF Analysis												
Area	Method 2 Visibility			Criteria Pollutants						Deposition		
	# Days with Extinction Change		Max. % Change	3-Hour SO ₂ µg/m ³	24-Hour SO ₂ µg/m ³	Annual SO ₂ µg/m ³	24-Hour PM ₁₀ µg/m ³	Annual PM ₁₀ µg/m ³	Annual NO _x µg/m ³	Total N kg/ha/yr	Total S kg/ha/yr	
	>5%	>10%										
Bridger WA, WY	0	0	0.3	0.002	0.001	9.149E-06	0.003	8.74E-05	9.01E-06	0.00004	0.00001	
Eagle Nest WA, CO	0	0	0.5	0.002	0.001	1.028E-05	0.006	9.09E-05	3.03E-05	0.00007	0.00002	
Fitzpatrick WA, WY	0	0	0.2	0.001	0.0003	4.857E-06	0.002	4.94E-05	3.01E-06	0.00002	0.00001	
Flat Tops WA, CO	0	0	0.8	0.005	0.001	1.541E-05	0.009	1.09E-04	6.73E-05	0.00009	0.00002	
Maroon Bells WA, CO	0	0	0.3	0.001	0.0004	3.911E-06	0.003	3.97E-05	7.17E-06	0.00006	0.00001	
Mount Zirkel WA, CO	0	0	1.8	0.015	0.004	8.954E-05	0.022	6.06E-04	6.59E-04	0.00066	0.00016	
Rawah WA, CO	0	0	3.1	0.016	0.006	8.483E-05	0.034	6.81E-04	4.77E-04	0.00042	0.00012	
Rocky Mtn National Park, CO	0	0	1.7	0.007	0.004	5.355E-05	0.023	5.02E-04	2.06E-04	0.00035	0.00010	
Savage Run WA, WY	0	0	3.3	0.046	0.009	1.69E-04	0.057	1.20E-03	1.38E-03	0.00092	0.00021	
Class I Threshold Values	0	0	5	1	0.2	0.1	0.3	0.2	0.1	0.005	0.005	

Note: Listed results represent the highest values modeled for the three-year period of meteorology (2001-2003).

PROPOSED PERMIT CONDITIONS:

The Division proposes to issue an air quality permit to Medicine Bow Fuel & Power, LLC for the construction of the Medicine Bow IGL Plant with the following conditions:

1. That authorized representatives of the Division of Air Quality be given permission to enter and inspect any property, premise or place on or at which an air pollution source is located or is being constructed or installed for the purpose of investigating actual or potential sources of air pollution and for determining compliance or non-compliance with any rules, standards, permits or orders.
2. That all substantive commitments and descriptions set forth in the application for this permit, unless superseded by a specific condition of this permit, are incorporated herein by this reference and are enforceable as conditions of this permit.
3. That Medicine Bow Fuel & Power, LLC shall obtain an operating permit in accordance with Chapter 6, Section 3 of the WAQSR.
4. That all notifications, reports and correspondences associated with this permit shall be submitted to the Stationary Source Compliance Program Manager, Air Quality Division, 122 West 25th Street, Cheyenne, WY 82002 and a copy shall be submitted to the District Engineer, Air Quality Division, 152 North Durbin Street, Suite 100, Casper, WY 82601.
5. That written notification of the anticipated date of initial startup, in accordance with Chapter 6, Section 2(i) of the WAQSR, is required not more than 60 days or less than 30 days prior to such date. Notification of the actual date of startup is required 15 days after startup.
6. That the date of commencement of construction shall be reported to the Administrator within 30 days of commencement. In accordance with Chapter 6, Section 2(h) of the WAQSR, approval to construct or modify shall become invalid if construction is not commenced within 24 months after receipt of such approval or if construction is discontinued for a period of 24 months or more. The Administrator may extend the period based on satisfactory justification of the requested extension.
7. That performance tests be conducted, in accordance with Chapter 6, Section 2(j) of the WAQSR, within 30 days of achieving a maximum design rate but not later than 90 days following initial start-up, and a written report of the results be submitted. The operator shall provide 15 days prior notice of the test date. If a maximum design rate is not achieved within 90 days of start-up, the Administrator may require testing be done at the rate achieved and again when a maximum rate is achieved.
8. That Medicine Bow Fuel & Power, LLC shall retain, at the Medicine Bow IGL Plant, records of the daily inspections, monthly observations, preventative maintenance records, Method 22 observations, and support information as required by this permit for a period of at least five (5) years from the date such records are generated and the records shall be made available to the Division upon request.

Medicine Bow IGL Plant

9. Initial performance testing, as required by Condition 7 of this permit shall be conducted on the following sources:

i. Combustion Turbines (CT-1, CT-2, and CT-3):

NO_x Emissions: Testing is to be performed on a 30-day rolling average using a certified CEM and the requirements of Subpart KKKK, 40 CFR part 60.

CO Emissions: Testing is to be performed on a 30-day rolling average using a certified CEM.

SO₂ Emissions: Compliance tests shall consist of three (3) 1-hour tests following EPA Reference Methods 1-4 and 6.

VOC Emissions: Compliance tests shall consist of three (3) 1-hour tests following EPA Reference Methods 1-4 and 25.

PM/PM₁₀ Emissions: Compliance tests shall consist of three (3) 1-hour tests following EPA Reference Methods 1-4 and 5.

Opacity: Opacity testing shall consist of three (3) 6-minute averages of the opacity as determined by Method 9 of 40 CFR part 60, Appendix A.

Mercury Emissions: Compliance test shall consist of three (3) 1-hour tests following EPA Reference Methods 1-4 and 29 or an equivalent EPA reference method upon Division approval.

ii. Auxiliary Boiler (AB):

NO_x Emissions: Compliance tests shall consist of three (3) 1-hour tests following EPA Reference Methods 1-4 and 7E.

CO Emissions: Compliance tests shall consist of three (3) 1-hour tests following EPA Reference Methods 1-4 and 10.

iii. Catalyst Regenerator (B-1), Reactivation Heater (B-2), HGT Reactor Charge Heater (B-3):

NO_x Emissions: Compliance tests shall consist of three (3) 1-hour tests following EPA Reference Methods 1-4 and 7E.

CO Emissions: Compliance tests shall consist of three (3) 1-hour tests following EPA Reference Methods 1-4 and 10.

- iv: Gasifier Preheaters (GP-1, GP-2, GP-3, GP-4, and GP-5):

NO_x and CO Emissions: Compliance testing for the first gasifier preheater tested shall consist of three (3) 1-hour tests following EPA Reference Methods 1-4, 7E and 10. Testing of subsequent gasifier preheaters shall consist of one (1) twenty-one (21) minute test following EPA Reference Methods 3, 7E, 10, and 19.

- v. Black Start Generators (Gen-1, Gen-2, and Gen-3):

NO_x, CO and VOC Emissions: Black Start Generators shall be tested in accordance with the requirements of Subpart JJJJ, 40 CFR part 60.

- vi. Fire Water Pump Engine (FW-Pump):

NO_x and CO Emissions: The Fire Water Pump Engine shall be tested in accordance with the requirements of Subpart IIII, 40 CFR part 60.

A test protocol shall be submitted for review and approval prior to testing. Notification of the test date shall be provided to the Division fifteen (15) days prior to testing. Results shall be submitted to this Division within 45 days of completion.

10. Emissions from the turbines (CT-1, CT-2, and CT-3) shall be limited to the following, and shall apply at all times:

Pollutant		lb/hr	tpy
NO _x	4 ppm _v @ 15% O ₂ (30-day rolling)	11.6 (30-day rolling)	50.6
CO	6 ppm _v @ 15% O ₂ (30-day rolling)	10.6 (30-day rolling)	46.2
SO ₂	--	2.5	10.8
VOC	1.4 ppm _v @ 15% O ₂	1.5	6.6
PM/PM ₁₀ (Filterable)	--	10.0	43.8
Hg	0.02 µg/Nm ³	--	4.33×10 ⁻⁵ (0.087 lb/yr)

11. That the opacity from the combustion turbines (CT-1, CT-2, and CT-3) shall be limited to 20 percent opacity as determined by Method 9 of 40 CFR part 60, Appendix A.

12. Medicine Bow Fuel & Power, LLC shall use the following in-stack continuous emission monitoring (CEM) equipment on the combustion turbines (CT-1, CT-2, and CT-3) to demonstrate continuous compliance with the emission limits set forth in this permit:
- i. Medicine Bow Fuel & Power, LLC shall install, calibrate, operate, and maintain a monitoring system, and record the output, for measuring NO_x emissions discharged to the atmosphere in ppm_v and lb/hr. The NO_x monitoring system shall consist of the following:
 - a. A continuous emission NO_x monitor located in the combustion turbine exhaust stack.
 - b. A continuous flow monitoring system for measuring the flow of exhaust gases discharged into the atmosphere.
 - c. An in-stack oxygen or carbon dioxide monitor for measuring oxygen or carbon dioxide content of the flue gas at the location NO_x emissions are monitored.
 - ii. Medicine Bow Fuel & Power, LLC shall install, calibrate, operate, and maintain a monitoring system, and record the output, for measuring CO emissions discharged to the atmosphere in ppm_v and lb/hr. The CO monitoring system shall consist of the following:
 - a. A continuous emission CO monitor located in the combustion turbine exhaust stack.
 - b. A continuous flow monitoring system for measuring the flow of exhaust gases discharged into the atmosphere.
 - c. An in-stack oxygen or carbon dioxide monitor for measuring oxygen or carbon dioxide content of the flue gas at the location CO emissions are monitored.
 - iii. Each continuous monitor system listed in this condition shall comply with the following:
 - a. 40 CFR part 60 Subpart KKKK – *Standards of Performance for Stationary Combustion Turbines*.
 - b. Monitoring requirements of Chapter 5, Section 2(j) of the WAQSR including the following:
 1. 40 CFR part 60, Appendix B, Performance Specification 2 for NO_x, Performance Specification 4 for CO, and Performance Specification 3 for O₂ and CO₂. The monitoring systems must demonstrate linearity in accordance with Division requirements and be certified in both concentration (ppm_v) and units of the standard (lb/hr).
 2. Quality Assurance requirements of Appendix F, 40 CFR part 60.

3. Medicine Bow Fuel & Power, LLC shall develop and submit for the Division's approval a Quality Assurance plan for the monitoring systems listed in this condition within 90 days of initial start-up.

13. Following the initial performance tests, as required by Condition 7 of this permit, compliance with the limits set forth in this permit shall be determined with data from the continuous monitoring systems required by Condition 12 of this permit as follows:
 - i. Exceedance of the limits shall be defined as follows:
 - a. Any 30-day rolling average calculated using valid data (output concentration and average hourly volumetric flowrate) from the CEM equipment required in Condition 12 which exceeds the ppm_v or lb/hr limits established for NO_x and CO in this permit. Valid data shall meet the requirements of WAQSR, Chapter 5, Section 2(j). The 30-day average emission rate shall be calculated at the end of each operating day as the arithmetic average of hourly emissions with valid data during the previous 30-day period.
 - ii. Medicine Bow Fuel & Power, LLC shall comply with all reporting and record keeping requirements as specified in Chapter 5, Section 2(g). Excess NO_x and CO emissions shall be reported in units of ppm_v and lb/hr.

14. Emissions from the auxiliary boiler and heaters shall be limited to the following, and shall apply at all times:

ID	Source	NO _x			CO		
		lb/MMBtu	lb/hr	tpy	lb/MMBtu	lb/hr	tpy
AB	Auxiliary Boiler	0.05	3.2	14.2	0.08	5.4	23.8
B-1	Catalyst Regenerator	0.05	1.1	4.6	0.08	1.8	7.8
B-2	Reactivation Heater	0.05	0.6	2.7	0.08	1.0	4.5
B-3	HGT Reactor Charge Heater	0.05	0.1	0.5	0.08	0.2	0.8
GP-1 – GP-5	Gasifier Preheaters	0.05	1.0	0.3	0.08	1.7	0.4

- 15a. That annually, or as otherwise specified by the Administrator, the Auxiliary Boiler (AB), Catalyst Regenerator (B-1), Reactivation Heater (B-2), and HGT Reactor Charge Heater (B-3) shall be tested to verify compliance with the NO_x and CO limits set forth in this permit. The first annual test is required the following calendar year after completion of the initial performance test. Testing for NO_x and CO shall be conducted following EPA reference Methods. Notification of the test date shall be provided to the Division fifteen (15) days prior to testing. Results of the tests shall be submitted to the Division within 45 days of completing the tests.

15b. The Air Quality Division shall be notified within 24 hours of any emission unit where the testing/monitoring required by 15(a) of this condition shows operation outside the permitted emission limits. By no later than 7 calendar days of such testing/monitoring event, the owner or operator shall repair and retest/monitor the affected emission unit to demonstrate that the emission unit has been returned to operation within the permitted emission limits. Compliance with this permit condition regarding repair and retesting/monitoring shall not be deemed to limit the authority of the Air Quality Division to cite the owner or operator for an exceedance of the permitted emission limits for any testing/monitoring required by 15(a) of this condition which shows noncompliance.

16. That emissions from the Black Start Generators shall be limited to the following:

ID	Source	NO _x			CO			VOC		
		g/hp-hr	lb/hr	tpy	g/hp-hr	lb/hr	tpy	g/hp-hr	lb/hr	tpy
Gen-1-Gen-3	Black Start Generators	1.0	6.4	0.8	2.4	15.5	1.9	0.9	5.7	0.7

17. That emissions from the Fire Water Pump Engine shall be limited to the following:

ID	Source	NO _x			CO		
		g/hp-hr	lb/hr	tpy	g/hp-hr	lb/hr	tpy
FW-Pump	Fire Water Pump Engine	4.75	6.0	1.5	0.3	0.4	0.1

18. That each Black Start Generator shall be limited to 250 hours of operation per year, and the Fire Water Pump shall be limited to 500 hours of operation per year. Medicine Bow Fuel & Power shall install, operate and maintain a non-resettable hour meter to determine the hours of operation of the generators. Records of the hours of operation shall be kept and maintained and made available to the Division upon request.

19. All other sources not covered by NSPS/NESHAP regulations are subject to a 20 percent opacity limit as determined by Method 9 of 40 CFR part 60, Appendix A.

20. During periods of startup, Medicine Bow Fuel & Power, LLC shall adhere to their procedures in their Startup/Shutdown Emission Minimization Plan, attached as Appendix B. This plan may be modified as deemed necessary by Medicine Bow Fuel & Power, LLC without amending the permit, but revisions to the plan shall be approved by the Division prior to implementation.

21. That Medicine Bow Fuel & Power, LLC shall comply with the applicable requirements of 40 CFR part 60, Subpart Dc for the auxiliary boiler.

22. That Medicine Bow Fuel & Power, LLC shall comply with the applicable requirements of 40 CFR part 60, Subpart Kb for the methanol, product gasoline, and heavy gasoline tanks.

23. That Medicine Bow Fuel & Power, LLC shall comply with the applicable requirements of 40 CFR part 60, Subpart Y for the coal preparation facilities.

24. That Medicine Bow Fuel & Power, LLC shall comply with the applicable requirements of 40 CFR part 60, Subpart IIII for the firewater pump engine.

25. That Medicine Bow Fuel & Power, LLC shall comply with the applicable requirements of 40 CFR part 60, Subpart JJJJ for the black start generators.
26. That Medicine Bow Fuel & Power, LLC shall comply with the applicable requirements of 40 CFR part 60, Subpart KKKK for the combustion turbines.
27. That Medicine Bow Fuel & Power, LLC shall comply with the applicable requirements of 40 CFR part 60, Subpart VVa for the IGL Plant.
28. That Medicine Bow Fuel & Power, LLC shall comply with the applicable requirements of Chapter 5, Section 3, Subpart DDDDD.
29. That Medicine Bow Fuel & Power, LLC shall comply with the applicable requirements of 40 CFR part 63, Subpart ZZZZ.
30. That Medicine Bow Fuel & Power, LLC shall comply with the applicable requirements of 40 CFR part 63, Subpart H.
31. That Medicine Bow Fuel & Power, LLC shall comply with the applicable requirements of 40 CFR part 63, Subpart EEEE.

Saddleback Hills Mine

32. That performance tests shall be conducted on the passive enclosure dust control systems (PECS) and atomizer/fogger systems to determine compliance with Condition 29(a). Method 22 of 40 CFR, Part 60, Appendix A shall be used to determine fugitive particulate emissions. Performance tests shall be at least 30 minutes in duration, with observations taken from each side of the enclosure. Notification of the test date shall be provided to the Division fifteen (15) days prior to testing. Results shall be submitted to this Division within 45 days of completion.
33. That the following requirements shall be met for all passive enclosure control systems (PECS) and atomizer/foggers systems at the mine:
 - a. The PECS and atomizer/foggers systems shall be operated and maintained so the system enclosure exhibits no visible emissions as determined by Method 22 of Appendix A, 40 CFR part 60.
 - b. That the atomizer/fogger systems and associated monitoring equipment shall be operated during all times that the respective coal preparation facilities are in operation.
 - c. Medicine Bow Fuel & Power, LLC shall conduct, at minimum, daily visual observations of the passive enclosure control systems (PECS) and atomizer/fogger systems to determine the presence of visible emissions. Records shall be kept documenting whether visual emissions are noted and the corrective action taken. These records shall be maintained for a period of five (5) years and shall be made available to the Division upon request.

- d. Medicine Bow Fuel & Power, LLC shall institute a monthly preventative maintenance plan for the atomizer/fogger systems.
34. That the coal preparation facilities are subject to 40 CFR part 60, Subpart Y. Subpart Y limits opacity from any coal processing and conveying equipment, including coal crushers and breakers, coal storage systems, and coal transfer and loading systems to less than 20 percent.
35. That Medicine Bow Fuel & Power, LLC shall submit a Chapter 6, Section 2 permit application, within 60 days of the promulgation of the revisions to Subpart Y, if the revisions to Subpart Y are inconsistent with the conditions of this permit.
36. The maximum coal production by calendar year at the Saddleback Hills Mine shall not exceed a total production rate of 3.2 million tons as described in the mine plan contained in the application. Medicine Bow Fuel & Power, LLC shall keep and maintain records of annual coal production for the Saddleback Hills Mine.
37. That the dead sealed stockpile shall not exceed 300,000 tons of coal in size. Medicine Bow Fuel & Power, LLC shall keep and maintain records of the size of the stockpile, amount of sealant applied to the storage pile, and dates of when the storage pile is accessed and restored.
38. That the underground mine stockpile shall not exceed a total size of 300,000 tons of coal. Medicine Bow Fuel & Power, LLC shall keep and maintain records of the size of the storage pile and coal throughput of the pile.
39. That the underground mine stockpile shall be treated with water, to the extent necessary, to minimize fugitive emissions. Medicine Bow Fuel & Power, LLC shall keep and maintain records of water treatment on the stockpile.
40. That all unpaved portions of haul roads, access roads, and work areas shall be treated with water and/or chemical suppressants on a schedule sufficient to control fugitive dust from vehicular traffic and wind erosion.

Appendix A
Modeling Information

Outside Point Sources Included in Modeling

Source ID	UTM East (m)	UTM North (m)	Base Elevation (m)	Stack Height (m)	Temp. (K)	Exit Velocity (m/s)	Stack Diam. (m)	CO Emission Rate (g/s)	NOx Emission Rate (g/s)
Colorado Interstate Gas - Laramie CS									
SRC36454	421705	4587401	2225	13.87	672.04	12.19	1.07	--	15.09
SRC36455	421705	4587401	2225	13.87	672.04	12.19	0.91	2.83	6.13
SRC36456	421705	4587401	2225	13.87	672.04	12.19	1.07	--	15.09
SRC36457	421705	4587401	2225	13.87	672.04	12.19	1.07	1.32	10.38
SRC36458	421705	4587401	2225	8.23	842.04	78.64	0.24	0.378	3.26
SRC36459	421705	4587401	2225	8.23	842.04	78.64	0.24	0.378	3.26
SRC36462	421705	4587401	2225	12.19	685.93	41.76	1.04	0.662	0.618
SRC36463	421705	4587401	2225	6.4	449.82	6.12	0.46	--	0.154
Kinder Morgan - Oil Springs CS									
SRC37392	395305	4649701	2042	7.92	596.48	24.05	0.43	0.106	0.975
SRC37393	395305	4649701	2042	7.92	596.48	24.05	0.43	0.106	0.975
Southern Star - Arlington CS									
SRC37771	399740	4606350	2328	10.97	922.04	50.51	1.01	0.518	0.71
Anadraroko E&P - Hanna Draw									
SRC36900	375779	4651513	1987	11	730.4	71.6	0.25	0.167	0.503
SRC36901	375779	4651524	1987	11	730.4	71.6	0.25	0.167	0.503
SRC36902	375779	4651536	1987	11	762	38.6	0.25	0.642	0.319
SRC36903	375779	4651547	1987	11	762	38.6	0.25	0.642	0.319

Facility: MBFP		Flares Modeled as Point Sources	
Project:		[when emissions are from multiple gases]	
<p>NOTES: 1) If the flare idle mode is to be modeled, treat as an ordinary point source since the heat release rate and the radiative heat loss are small. 2) The effective stack height need not be used in the model as the conservative approach would be to ignore the increased stack height. 3) Enter all input values only in the yellow cells. Results are in bold red.</p>			
		Flare	
		Flare1	
		HF Flare - cold startup	
		ambient temperature (F)	50 assumed
		stack temperature (F)	1832 -- exit (post combustion) temperature
		ambient temperature (K)	283
		stack temperature (K)	1273
		volumetric flow rate (acfm)	399,113 flow to flare, at actual pre-combustion conditions
		volumetric flow rate (scfm)	967,006 flow to flare, at STP
		heating value (BTU/ft ³)	101 BTU/scf
		heat release rate (BTU/hr)	5.986E+09
		radiative heat loss (%) ¹	55
		net heat release rate (BTU/hr)	2.649E+09
		net heat release rate (MWsec)	7.761E+08
		optional --> actual stack height (ft)	150.0
		effective stack height (ft)	283.9
		actual stack exit velocity (fps)	65.62
		actual stack exit velocity (m/sec)	20.00
		effective stack diameter (ft)	44.75
			86.55 meters
			13.64 meters

-- Values for model input (NOTE: flow rate not a model input)

¹ Default value is 55% (SCREEN3). This is conservative.

NOTE: 1 BTU = 1055 Joule = 0.001055 MJ = 252 calories = 0.252 kcal

Facility: Project:		Flares Modeled as Point Sources (when emissions are from multiple gases)	
<p>NOTES: 1) If the flare (idle mode is to be modeled, treat as an ordinary point source since the heat release rate and the radiative heat loss are small. 2) The effective stack height need not be used in the model as the conservative approach would be to ignore the increased stack height. 3) Enter all input values only in the yellow cells. Results are in bold red.</p>			
Flare	Flare2		
EP #	LP Flare		
Description	50		assumed
ambient temperature (°F)	1832		** exit (post combustion) temperature
stack temperature (°F)	283		
ambient temperature (°K)	1273		
volumetric flow rate (acfm)	2,479		flow to flare, at actual pre-combustion conditions
volumetric flow rate (scfm)	3,758		flow to flare, at STP
heating value (BTU/ft ³)	256		BTU/scf
heat release rate (BTU/hr)	5.784E+07		
radiative heat loss (%) ^a	55		
net heat release rate (BTU/hr)	2.594E+07		
net heat release rate (J/sec)	7.609E+06		
optional -> actual stack height (ft)	241.1		
effective stack height (ft)	255.8		** 78.0 m
actual stack exit velocity (fps)	66		**
actual stack exit velocity (m/sec)	20.00		
effective stack diameter (ft)	4.43		** 1.35 m

** Values for model input (NOTE: flow rate not a model input)

^a Default value is 55% (SCREEN3). This is conservative.

Appendix B
Startup/Shutdown Emission Minimization Plan

DRAFT (Rev 0)
Startup/Shutdown Emission Minimization Plan
Medicine Bow Fuel & Power

40 CFR §60.11 (d): At all times, including periods of startup, shutdown, and malfunction, owners and operators shall, to the extent practicable, maintain and operate any affected facility including associated air pollution control equipment in a manner consistent with good air pollution control practice for minimizing emissions. Determination of whether acceptable operating and maintenance procedures are being used will be based on information available to the Administrator which may include, but is not limited to, monitoring results, opacity observations, review of operating and maintenance procedures, and inspection of the source.

The goal of this Plan is to provide guidelines and suggestions for steps that will minimize air emissions during startup and shutdown periods, in accordance with Clean Air Act permits and regulations, including the provisions from 40 CFR 60 as cited above.

Specific startup and shutdown operating procedures for all process units in the Plant shall incorporate the elements of this Plan to the greatest extent possible.

Flaring Associated with Startup – General Comments

- Commission all downstream equipment and prepare them for operation prior to gasifier startup. This will include preparation of the:
 1. Low Temperature Gas Cleanup (LTGC),
 2. Sour Water Stripper,
 3. Acid Gas Removal (AGR),
 4. Sulfur Recovery Unit (SRU) - Claus Plant,
 5. CO₂ compression, and
 6. Methanol synthesis loop.
- Preparation will include completion of commissioning activities and final signoff, establishment of normal operating levels for fluids, preheating of required components, and start of circulating pumps as necessary.

Flaring Associated with Startup – Activities Following Gasifier Startup

Once a gasifier is started up certain conditions must be met prior to introducing syngas to subsequent stages. These conditions include:

- Gasifier
 - One gasifier will be started at a time. Subsequent gasifiers will not be started until the downstream equipment is ready to receive the increase in syngas volume.
 - After light off a leak check of gasifier piping and components is required.
 - A low pressure and normal operating pressure check are required.
 - Raw syngas will be diverted to flare until after checks are complete. At this stage pressure can be bled into downstream piping to equalize

DRAFT (Rev 0)
Startup/Shutdown Emission Minimization Plan
Medicine Bow Fuel & Power

2

pressures and then the control valve can be fully opened and placed in automatic control.

- The amount of syngas sent downstream will be determined by the startup and status of downstream units.
- Start-up flaring will be at a reduced rate due to a planned slow ramp up of the plant.
- **LTGC**
 - Leak checks are required after pressurization, but not to delay input to the AGR system.
 - This stage includes several steam generators needed to ensure the syngas temperature is in spec for downstream components. Failure to cool down the syngas can result in a high temperature scenario requiring flare to avoid damage to downstream equipment and catalysts.
 - The syngas temperature must be monitored as the system heats up to prevent a high temperature trip. Temperature setpoints to be defined by AGR vendor and by catalyst vendors for COS and Sour Shift catalysts.
- **Sour Water Stripper**
 - The sour water unit will send low pressure sour gas to the Claus plant for conversion of ammonia and H₂S to N₂, H₂O, and SO₂. Base case is to vent this stream during startup until the SRU is started up.
- **AGR**
 - The AGR will be slowly ramped up at an estimated 10% of design syngas flow per hour.
 - Syngas temperature must be maintained below AGR vendor specifications.
 - The clean high pressure syngas must be vented to flare until the total sulfur in the syngas comes into the specification of less than 0.5 ppmv.
 - Start-up flaring will be at a reduced rate due to slow ramp up of plant.
- **Claus Plant**
 - When the acid gas reaches approximately 40% H₂S content it can be sent from the AGR to the SRU. Prior to this we will assume the acid gas is flared.
 - Start-up flaring will be at a reduced rate due to slow ramp up of plant.
- **Methanol Synthesis**
 - No syngas can be sent to the Methanol synthesis loop until sulfur is in spec. Syngas sulfur content must be less than 0.5 ppmv prior to sending to methanol synthesis.

DRAFT (Rev 0)
Startup/Shutdown Emission Minimization Plan
Medicine Bow Fuel & Power

3

- o If CO₂ is out of spec (>2% vol) for several hours it will result in high water content in the methanol which is not acceptable.
- o **Syngas flow rate must be at least 50% of design flow rate prior to being sent to methanol synthesis to prevent compressor surge. This rate will be reviewed and verified during compressor design and surge protection design.**
- o After the Methanol step the effluents are primarily low sulfur fuel gases sent to the power block and liquid methanol sent to storage or MTG. No further flaring events as part of startup are expected.

Venting Associated with Startup

- CO₂ Capture
 - o CO₂ produced from AGR will need to be vented until sufficient flow is produced to start the compressors. This flow rate is expected to be 25% of design flow rate assuming two compressor trains and a 50% turndown capacity. *This will require confirmation from compressor vendor during FEED engineering.*
 - o Start-up venting will be at a reduced rate due to slow ramp up of plant.
 - o If during startup export of CO₂ is not feasible then CO₂ will continue to be vented.
- Gasifier heaters
 - o Initially all five heaters will be online. Heaters will be started shortly after the refractory is installed to cure the refractory. After refractory cure, the heaters will need to remain in operation to prevent moisture accumulation; otherwise another multiday heater dryout session will be required prior to startup.
 - o Medicine Bow will attempt to startup as soon as possible after refractory cure is complete to minimize heater operations. This is the basis of the current plan to commission units from the end of the process to the beginning to ensure that as soon as the gasifiers are commissioned, the plant will be ready to startup and receive syngas. This plan is dependent on the construction and commissioning schedule and a situation may develop where light off is delayed after cure is complete. The time of this delay will determine if the heaters will remain on or be shutdown.
 - o As each gasifier is prepared for startup the heaters will be turned off and removed. After full startup is complete, only one heater will be in operation on the spare gasifier.
- MTG heaters
 - o These heaters will be brought on line when the unit is prepared to receive methanol and be operated per design.

DRAFT (Rev 0)
Startup/Shutdown Emission Minimization Plan
Medicine Bow Fuel & Power

4

- Power block
 - The ASUs, which are the major power load for the plant, will be started several days in advance of the gasifier light-off to establish required temperatures in the cold box to generate purified oxygen. Two turbines with heat recovery steam turbine power will be required to start up both ASUs. If the steam turbine is not available, then all three gas turbines at reduced load will be required to startup the ASUs.
 - During plant startup most process units will begin to draw power in preparation for gasifier light off. The main exceptions are the CO₂ Compressors, Methanol Synthesis compressor, and MTG compressor units. All three gas turbines with heat recovery steam power are required to support the plant as it is prepared for full start-up.
- Fugitive emissions
 - Fugitive emissions will not start until Methanol and gasoline are synthesized
 - Tank emissions will be at a reduced rate initially as storage tanks are filled.
- Aux boiler
 - The boiler will be in operation during startup. At a minimum it will be turned down and floated on the system if the heat recovery steam generators are able to support plant steam requirements. *If more steam is required as defined in the FEED, then the aux boiler may be operated at its maximum rate.* After syngas is routed to methanol and the startup steam loads are reduced and process steam is available, the auxiliary boiler can be reduced to minimum.
- Flare pilots
 - Pilots will be lit as part of preparation for gasifier light off.