



URS Corporation  
8181 East Tufts Avenue  
Denver, CO 80237  
Tel: 303.694.2770  
Fax: 303.694.3946

Offices Worldwide

December 31, 2007

Chad Schlichtemeier  
Wyoming Department of Environmental Quality  
Air Quality Division / NSR Program Manager  
Herschler Building  
122 West 25<sup>th</sup> Street  
Cheyenne, WY 82002



**Subject: Transmittal for Medicine Bow Fuel & Power LLC  
Revised PSD Air Quality Permit Application (AP-5873) for Medicine Bow  
Industrial Gasification and Liquefaction Plant**

Dear Mr. Schlichtemeier:

Enclosed please find eight hardcopies and one electronic copy of a revised Prevention of Significant Deterioration (PSD) permit application for the proposed underground coal mine and industrial gasification & liquefaction (IGL) facility, to be owned and operated by Medicine Bow Fuel & Power LLC (MBFP) and located near Medicine Bow, WY.

As discussed in our meeting on November 29, 2007, several key aspects of the proposed facility have changed. This amended PSD permit application provides comprehensively revised information based on the new process. The remainder of this transmittal letter provides a summary of the process design change, effects on potential emission rates, and issues relating to air quality modeling.

**Process Design Change**

Under the previous design, the proposed facility produced commercial diesel fuel and naphtha using the Rentech Fischer-Tropsch (FT) conversion process. The process design has been revised to produce commercial gasoline and other products. The facility continues to include the underground Saddleback Hills Mine, which provides coal feedstock to the IGL facility with no change in production rate, and will be sited in the same location as previously proposed.

The process will employ General Electric's (GE) gasification technology for quench gasification, UOP's SELEXOL<sup>®</sup> acid gas removal process, and a Sulfur Recovery Unit (SRU), as previously proposed. However, gasoline production will be accomplished through the use of Davy Process Technology's methanol synthesis process, followed by ExxonMobil's methanol-to-gasoline (MTG) process. A complete process description for the facility, including the

methanol synthesis and MTG process units, is included in Section 2 of this revised PSD application, along with an updated process flow diagram.

The following changes to emission sources result from the revised process design.

- Three (3) process heaters and an auxiliary boiler replace six (6) previously proposed process heaters.
- Gasoline and methanol storage tanks replace previously proposed diesel fuel and naphtha storage tanks.
- The sulfur recovery unit (SRU) incinerator has been removed; tail gas is now recycled back into the process to produce increased sulfur product.
- A low pressure (LP) flare has been added to receive low pressure vents in cases of startup, shutdown, and malfunction (SSM).
- The originally proposed emergency flare (Flare 1) has been renamed as a high pressure (HP) flare to receive high pressure vent streams in cases of SSM.
- Volatile organic compound (VOC) and hazardous air pollutant (HAP) process equipment leaks are more significant due to increased VOC/HAP concentrations and volatility in several process streams.

Another change relates to the type of fuel gas produced within the IGL facility. Previously, excess syngas (primarily hydrogen and carbon monoxide) produced within the process was used to fuel the combustion turbines and other combustion equipment at the facility (with supplementary natural gas, as needed). Plant-produced fuels will now consist of a fuel gas mixture containing fuel gas, LPG, and supplemental natural gas. During normal operations, the combustion turbines, process heaters, auxiliary boiler, and most other combustion units will combust the fuel gas mixture. As was true of the previous process, natural gas will be fired exclusively during startup of each combustion unit.

#### **Change in Potential Emission Rates**

The facility wide emission summary is presented somewhat differently in Appendix B to the permit application document than it was previously. As requested by the Wyoming Department of Air Quality, normal annual emissions (with no SSM) are presented; these are shown on the first page of the emission calculation spreadsheets. The second emission summary page within Appendix B provides full-year emissions from a cold startup year, such as the initial year of operations. On that summary page, a partial year of startup emissions and a partial year of normal operating emissions are totaled at the bottom of the page. The numbers of hours that each emission source operates under each scenario are clearly shown.

Table 1 below presents a summary of proposed potential-to-emit (PTE) emission rates with this revised application and a comparison to proposed PTE rates from the previous process for a normal year of operation (no cold startups).

**Table 1. Proposed PTE Rates for IGL Facility (Normal Annual Operation)**

	Revised PTE (Dec 2007) [tpy]	Previous PTE (June 2007) <sup>1</sup> [tpy]	Emission Change [tpy]
NO <sub>x</sub>	233.8	242.1 <sup>1</sup>	-8.3
CO	146.8	140.2 <sup>1</sup>	+6.6
VOC	198.3	114.2 <sup>1</sup>	+84.1
SO <sub>2</sub>	32.5	42.4 <sup>1</sup>	-9.9
PM <sub>10</sub>	192.3	216.0 <sup>1</sup>	-23.7
HAPs	29.2	4.2	+25.0

Notes:

1. PTE Emissions as submitted in the November 17, 2007 response to comments.

The most significant emission related change is the increase in VOC and HAP emissions. Based on HAP emissions of 29.2 tpy, the IGL facility will be a major source of HAPs. The largest contributors to HAP and VOC emissions are the gasoline storage tanks and equipment leaks from the methanol synthesis and MTG processes. Emissions of nitrogen oxides (NO<sub>x</sub>), sulfur dioxide (SO<sub>2</sub>), and particulate matter (PM<sub>10</sub>) are reduced by the proposed process change. Carbon monoxide (CO) emissions increase slightly.

**Air Quality Impacts/Changes to Modeling Analysis**

Due to the significant increase in HAP emissions, the revised permit application includes new HAP risk modeling. The HAP modeling report is included in Appendix H.

VOC emissions are rarely modeled for PSD permit applications. Consequently, no VOC impact analysis was included in the original permit application and no additional VOC modeling is included in this revised permit application.

With regard to criteria pollutant modeling, MBFP believes that no additional modeling is required. Emissions of NO<sub>x</sub>, SO<sub>2</sub>, and PM<sub>10</sub> have decreased due to the process change. Furthermore, these decreases occurred at similar source types in similar locations.

In contrast, CO emissions have increased by 6.6 tpy (a percentage increase of less than 5 percent). This change is not likely to significantly change air quality impacts. Near-field maximum predicted CO concentrations were less than 13 percent of the National Ambient Air Quality Standards (NAAQS) and Wyoming Ambient Air Quality Standards (WAAQS) for both the 1-hour and 8-hour averages. With regard to far-field modeling, CO was not modeled because this pollutant has no impact on visibility or acid deposition. A more robust analysis of potential air quality impacts related to the process change is included in Appendix I.

**Conclusion**

The revised process design change is a significant change from the originally proposed facility. We have prepared a comprehensively revised PSD application due to the extent of the design changes, with significant changes to process- and emission-related sections of the application. We would be happy to meet with you and your staff to discuss the proposed facility design,

Chad Schlichtemeier  
December 31, 2007  
Page 4

changes to emission calculations, and the air quality impact analyses, at your earliest convenience. MBFP would like to receive a PSD permit by April 2008; a meeting within the next week would be greatly appreciated to determine if any additional information will be required.

Please contact me via phone at (303) 740-3824 or email to Susan\_Bassett@URSCorp.com if you need additional information or copies of the revised application.

Sincerely,



Susan Bassett  
URS Denver Air Quality Team Leader

Enclosures Revised PSD Permit Applications (8 copies)  
CD with electronic version of application

DEQ 000082

**PREVENTION OF SIGNIFICANT  
DETERIORATION PERMIT APPLICATION**

**Medicine Bow Fuel & Power LLC  
Industrial Gasification & Liquefaction  
(IGL) Plant**

**Carbon County, Wyoming**

**December 31, 2007 Amended Permit Application**

**DEQ 000083**

# TABLE OF CONTENTS

---

<b>Section 1</b>	<b>Introduction.....</b>	<b>1-1</b>
1.1	General Facility Description.....	1-1
1.2	Facility Location.....	1-2
1.3	Prevention of Significant Deterioration Applicability.....	1-2
1.4	Standard Industrial Classification.....	1-7
<b>Section 2</b>	<b>Process Description.....</b>	<b>2-1</b>
2.1	Coal Mining.....	2-1
2.2	Gasoline Production.....	2-1
2.2.1	Coal Preparation (1100).....	2-1
2.2.2	Gasification (1200).....	2-2
2.2.3	Syngas Conditioning (1300).....	2-2
2.2.4	SELEXOL <sup>®</sup> Acid Gas Removal (2100).....	2-6
2.2.5	Methanol Synthesis (4500).....	2-7
2.2.6	Methanol to Gasoline (5500).....	2-7
2.3	CO <sub>2</sub> Recovery (2200) and Production.....	2-9
2.4	Sulfur Recovery (3100) and Production.....	2-10
2.5	Ancillary Operations.....	2-11
2.5.1	Power Generation (7100).....	2-11
2.5.2	Air Separation Unit (6100).....	2-11
2.5.3	Intermediate and Product Storage (8100-8200).....	2-11
2.5.4	Slag Handling and Water Cleanup (1200).....	2-12
2.5.5	Water Treatment (1300 and 7100).....	2-12
2.5.6	Flares (8900).....	2-13
2.5.7	Other Utilities (8300).....	2-13
2.6	Startup Activities.....	2-13
<b>Section 3</b>	<b>Emission Estimates.....</b>	<b>3-1</b>
3.1	Saddleback Hills Mine.....	3-1
3.2	The Plant.....	3-2
3.2.1	Emission Sources.....	3-2
3.2.2	Normal Operations.....	3-3
3.2.3	Cold Start/Initial Year Operations.....	3-4
3.2.4	Malfunctions and Other Events.....	3-5
3.2.5	Emissions of PSD-Regulated Pollutants.....	3-6
3.2.6	Source-Specific Calculation Methods.....	3-6
<b>Section 4</b>	<b>Best Available Control Technology.....</b>	<b>4-1</b>
4.1	BACT Review Process.....	4-1
4.2	BACT Summary.....	4-3
4.3	Combustion Turbine Control Technology Review.....	4-4
4.3.1	Nitrogen Oxides BACT Analysis for the Combustion Turbines.....	4-4

# TABLE OF CONTENTS

4.3.2	Sulfur Dioxide BACT Analysis for the Combustion Turbines .....	4-8
4.3.3	Volatile Organic Compound BACT Analysis for the Combustion Turbines.....	4-12
4.3.4	Particulate Emissions BACT Analysis for the Combustion Turbines .....	4-14
4.3.5	Startup Emissions BACT Analysis for the Combustion Turbines .....	4-16
4.4	Fired Heater and Boiler Control Technology Review .....	4-16
4.4.1	NO <sub>x</sub> BACT Analysis for the Fired Heaters and Boiler.....	4-16
4.4.2	CO and VOC BACT Analysis for the Fired Heaters and Boiler.....	4-19
4.4.3	SO <sub>2</sub> BACT Analysis for the Fired Heaters and Boiler .....	4-21
4.4.4	Particulate Emissions BACT Analysis for the Fired Heaters and Boiler.....	4-22
4.4.5	Startup Emissions BACT Analysis for the Fired Heaters and Boiler.....	4-23
4.5	Storage Tank Control Technology Review.....	4-23
4.6	Material Handling Control Technology Review.....	4-26
4.7	Process Fugitive Emissions Control Technology Review .....	4-27
4.8	Sulfur Recovery Unit (SRU) Control Technology Review .....	4-27
4.9	Carbon Dioxide Vent Stack (Startup Operations Only).....	4-28
4.10	Gasifier Preheating Control Technology Review (Startup Operations Only).....	4-29
4.11	Black-Start Generator Control Technology Review (Startup Operations Only).....	4-30
4.12	Firewater Pump Control Technology Review (Backup Operations Only) .....	4-31
4.13	Mercury Emission Reduction .....	4-31
4.14	Mine Long-Term Coal Storage.....	4-32
<b>Section 5</b>	<b>Regulatory Review .....</b>	<b>5-1</b>
5.1	Wyoming Air Quality Regulations .....	5-1
5.1.1	Chapter 2 Ambient Standards .....	5-1
5.1.2	Chapter 3 General Emission Standards.....	5-2
5.1.3	Chapter 6 Permitting Requirements.....	5-4
5.1.4	Chapter 7 Monitoring Regulations.....	5-5
5.2	Federal Regulations .....	5-5
5.2.1	New Source Performance Standards (NSPS) .....	5-5
5.2.2	National Emissions Standards for Hazardous Air Pollutants (NESHAP) .....	5-7
5.2.3	Chemical Accident Prevention Provisions.....	5-8
<b>Section 6</b>	<b>Near Field Air Quality Impact Analysis .....</b>	<b>6-1</b>
6.1	Background.....	6-1

# TABLE OF CONTENTS

---

6.2	Description of Proposed Project .....	6-2
6.2.1	Site Location .....	6-2
6.2.2	Source Emissions and Parameters .....	6-4
6.3	Standards and Criteria Levels .....	6-8
6.4	Near-Field Modeling Method .....	6-9
6.4.1	Near-Field Modeling.....	6-9
6.4.2	Model Selection and Setup .....	6-9
6.4.3	Data Bases for Air Quality Assessment.....	6-11
6.4.4	Meteorological Data.....	6-12
6.4.5	Receptor Grid.....	6-18
6.5	Growth Analysis .....	6-18
6.6	Modeling Results .....	6-22
6.6.1	SO <sub>2</sub> Modeling Demonstration.....	6-22
6.6.2	PM/PM <sub>10</sub> Modeling Demonstration.....	6-23
6.6.3	CO Modeling Demonstration.....	6-23
6.6.4	NO <sub>x</sub> Modeling Demonstration.....	6-24
6.6.5	Discussion of Results.....	6-25
<b>Section 7</b>	<b>Far Field Air Quality Impact Analysis .....</b>	<b>7-1</b>
7.1	Background.....	7-1
7.2	Description of Proposed Project .....	7-2
7.2.1	Site Location .....	7-2
7.2.2	Source Emissions .....	7-2
7.2.3	Sources Included In CALPUFF Modeling .....	7-2
7.2.4	Reference Reports.....	7-7
7.3	Long-Range Transport Modeling Method .....	7-9
7.3.1	Long-Range Transport Modeling .....	7-9
7.3.2	Model Selection and Setup .....	7-9
7.3.3	Domain.....	7-10
7.3.4	LULC and TERREL Processing.....	7-11
7.3.5	Hourly Surface and Precipitation Data .....	7-12
7.3.6	Upper Air Sounding Data .....	7-12
7.3.7	MM5 Data.....	7-12
7.3.8	CALMET .....	7-12
7.3.9	PSD Class I Increment Significance Analysis.....	7-17
7.3.10	Class I Area Visibility Reduction Analysis .....	7-18
7.3.11	Total Nitrogen and Sulfur Deposition Analyses .....	7-18
7.4	Modeling Results .....	7-19
7.4.1	Calpuff Modeling Results.....	7-19
7.4.2	Soil and Vegetation Analysis.....	7-19
7.5	Conclusion .....	7-23



# TABLE OF CONTENTS

---

## List of Tables

Table 1.1	Annual Criteria Pollutant Emissions (tpy)
Table 1.2	Annual HAPs Emissions (tpy)
Table 3.1	Mine Development Particulate Emissions
Table 3.2	Emission Units and Fugitive Sources
Table 3.3	Emissions Resulting from Normal Operations (tpy)
Table 3.4	Annual Emissions Resulting from Cold Startup (tpy)
Table 3.5	Emissions Resulting from Malfunctions and Other Events
Table 3.6	Typical Fuel Gas Mixture Composition
Table 4.1	BACT Applicability
Table 4.2	Summary of BACT Applied to the MBFP Project
Table 4.3	Storage Tanks Summary
Table 4.4	Gasifier Preheater BACT Analysis Summary
Table 4.5	Black Start Generator BACT Analysis Summary
Table 4.6	Emergency Firewater Pump BACT Analysis Summary
Table 5.1	Ambient Air Quality Standards
Table 5.2	Subpart Kb Tanks List
Table 6.1	Annual Modeled Emission Levels
Table 6.2	Modeled Project Source Parameters
Table 6.3	PSD Class II Increments
Table 6.4	Significant Impact Levels (SILs)
Table 6.5	Data Completeness Evaluation, Rawlins NWS Hourly Surface Meteorological Data
Table 6.6	Normalized Frequency Distribution of Wind Speed and Direction of Rawlins Hourly Surface Meteorological Data (2000, 2001, 2003, 2004, and 2005)
Table 6.7	Nearby Site-Specific Meteorological Data Completeness Capture
Table 6.8	Normalized Frequency Distribution of Wind Speed and Direction of On-Site Meteorological Data (2000, 2001, 2003, 2004, and 2005)
Table 6.9	Medicine Bow - Maximum Predicted SO <sub>2</sub> Concentrations from the Proposed Project for Comparison with the SILs
Table 6.10	Maximum Predicted PM/PM <sub>10</sub> Concentrations from the Proposed Project for Comparison with the SILs
Table 6.11	Maximum Predicted CO Concentrations from the Proposed Project for Comparison With the SILs

# TABLE OF CONTENTS

---

Table 6.12	Maximum Predicted NO <sub>x</sub> Concentrations from the Proposed Project for Comparison with the SILs
Table 7.1	Class-I Areas and Sensitive Class II Areas Within 300 km
Table 7.2	Maximum Emission Rate from All Sources
Table 7.3	24 hour Averaged Emission Inventory for CALPUFF (3-hour and 24-hour SO <sub>2</sub> , and 24-hour PM <sub>10</sub> and Visibility)
Table 7.4	Annual Averaged Emission Inventory for CALPUFF (Annual NO <sub>x</sub> , SO <sub>2</sub> , and PM <sub>10</sub> and Deposition)
Table 7.5	Size Distribution of Secondary Organic Aerosols (SOA)
Table 7.6	Source Location and Parameter
Table 7.7	CALMET Model Options
Table 7.8	CALPUFF Model Options
Table 7.9	2001 CALPUFF Modeling Results
Table 7-10	2002 CALPUFF Modeling Results
Table 7-11	2003 CALPUFF Modeling Results

## List of Figures

Figure 1.1	Site Location Map
Figure 1.2	Mine South Portal Site Layout
Figure 1.3	Mine East Portal / Plant Layout
Figure 1.4	Process Equipment Layout
Figure 2.1	Coal Mine Process Flow Diagram
Figure 2.2	Plant Process Flow Diagram
Figure 6.1	Medicine Bow Project Site Area, View from South Side
Figure 6.2	Medicine Bow Project Site Area, View Over Coal Hills Toward Elk Mountain
Figure 6.3	Good Engineering Practice (GEP) Stack Height Assessment, Building and Source Location Depiction
Figure 6.4	Wind Rose, Five Year Period
Figure 6.5	Surrounding Terrain as used in AERMAP
Figure 6.6	Modeled Receptor Grid
Figure 6.7	NO <sub>x</sub> Impact Area
Figure 6.8	PM <sub>10</sub> 24-hour Impact Area
Figure 6.9	SO <sub>2</sub> 24-hour Impact Area

# TABLE OF CONTENTS

---

- Figure 7.1 Relative Location of Modeling Domain, MM5 Domain, Class I and Sensitive Class II areas, and Source based on UTM Coordinates
- Figure 7.2 Modeling Domain with Receptors of Class I and Sensitive Class II Areas, Precipitation Data Monitoring Station, Ozone Monitoring Station, Surface Meteorological Data Monitoring Station, and Project Location

## List of Appendices

- Appendix A Wyoming Permit Application Form
- Appendix B Emission Calculations
- Appendix C Manufacturer Specifications
- Appendix D Major Equipment List and SCCs
- Appendix E BACT Review of Recent NOx Limits for Combined Cycle Combustion Turbines Fueled With Other Gaseous Fuels
- Appendix F Coal Storage BACT Analysis
- Appendix G Mercury Removal Cost Analysis
- Appendix H December 2007 HAP Modeling Results
- Appendix I Analysis of Criteria Pollutant Modeling Sufficiency
- Appendix J June 2007 Modeling Files
- Appendix K Responses to WDEQ July 17, 2007 Modeling Comments
- Appendix L NRCS Irrigated and Nonirrigated Yields by Map Unit for Carbon County, Wyoming
- Appendix M NRCS Acreage and Proportionate Extent of the Soils for Carbon County, Wyoming
- Appendix N NRCS Rangeland Productivity and Plant Composition
- Appendix O Mesoscale Model Simulations in Quasi-Forecast Mode of the Great Western Storm of 16-20 March 2003

## Acronyms

---

agl	Above grade level
AGR	Acid gas removal
AP-42	EPA AP-42 Emission Factors
AQRV	Air Quality Related Value
ASU	Air Separation Unit
AVO	Audio/visual/olfactory
BACT	Best Available Control Technology
BOL	Beginning of Life
BPD	Barrels per day
bpip	Building Profile Input Program
Btu	British thermal unit
CAA	Clean Air Act
CaCO <sub>3</sub>	Calcium carbonate
CAM	Compliance Assurance Monitoring
CDPHE	Colorado Department of Public Health and Environment
CFR	Code of Federal Regulations
Cl <sub>2</sub>	Chlorine
CO	Carbon monoxide
CO <sub>2</sub>	Carbon dioxide
COS	Carbonyl sulfide
CS <sub>2</sub>	Carbon disulfide
DAT	Deposition Analysis Thresholds
DEM	Digital Elevation Model
DLN	Dry Low NO <sub>x</sub>
DME	Dimethyl ether
dscf	Dry standard cubic feet
EC	Elemental carbon
EFR	External floating roof
EOL	End of life
EPA	U.S. Environmental Protection Agency
ESP	Electrostatic precipitator
°F	Degrees Fahrenheit
F	Fluorine
FGD	Flue gas desulfurization
FGR	Flue gas recirculation
FLAG	Federal Land Managers Air Quality Related Values Working Group
ft	Feet
g	Gram
gal	Gallons
GE	General Electric Co.
GEP	Good Engineering Practice
GPM	Gallons per minute
H <sub>2</sub>	Hydrogen
H <sub>2</sub> S	Hydrogen sulfide
HAP	Hazardous air pollutant
HGT	Heavy gasoline treatment

## Acronyms

---

agl	Above grade level
AGR	Acid gas removal
AP-42	EPA AP-42 Emission Factors
AQRV	Air Quality Related Value
ASU	Air Separation Unit
AVO	Audio/visual/olfactory
BACT	Best Available Control Technology
BOL	Beginning of Life
BPD	Barrels per day
bpip	Building Profile Input Program
Btu	British thermal unit
CAA	Clean Air Act
CaCO <sub>3</sub>	Calcium carbonate
CAM	Compliance Assurance Monitoring
CDPHE	Colorado Department of Public Health and Environment
CFR	Code of Federal Regulations
Cl <sub>2</sub>	Chlorine
CO	Carbon monoxide
CO <sub>2</sub>	Carbon dioxide
COS	Carbonyl sulfide
CS <sub>2</sub>	Carbon disulfide
DAT	Deposition Analysis Thresholds
DEM	Digital Elevation Model
DLN	Dry Low NO <sub>x</sub>
DME	Dimethyl ether
dscf	Dry standard cubic feet
EC	Elemental carbon
EFR	External floating roof
EOL	End of life
EPA	U.S. Environmental Protection Agency
ESP	Electrostatic precipitator
°F	Degrees Fahrenheit
F	Fluorine
FGD	Flue gas desulfurization
FGR	Flue gas recirculation
FLAG	Federal Land Managers Air Quality Related Values Working Group
ft	Feet
g	Gram
gal	Gallons
GE	General Electric Co.
GEP	Good Engineering Practice
GPM	Gallons per minute
H <sub>2</sub>	Hydrogen
H <sub>2</sub> S	Hydrogen sulfide
HAP	Hazardous air pollutant
HGT	Heavy gasoline treatment

## Acronyms

---

HHV	Higher heating value
HNO <sub>3</sub>	Nitric acid
HP	High pressure
hp	Horsepower
hr	Hour
hr/yr	Hours per year
HRSG	Heat recovery steam generator
IFR	Internal floating roof
IGCC	Integrated gasification combined cycle
IGL	Industrial Gasification and Liquefaction
in	Inch
IWAQM	Interagency Working Group on Air Quality Modeling
km	kilometer
LAC	Level of acceptable extinction change
LAER	Lowest Achievable Emission Rate
lb	Pound
lb/yr	Pounds per year
LDAR	Leak Detection and Repair
LHV	Lower heating value
LP	Low pressure
LPG	Liquefied petroleum gas
LTGC	Low-temperature gas cleanup
LULC	Land Use Land Cover
m	Meter
µg/m <sup>3</sup>	Micrograms per cubic meter
m <sup>3</sup>	Cubic meters
MACT	Maximum Achievable Control Technology
MDEA	Methyldiethanolamine
min	Minute
MMBtu	Million British thermal units
MMscf	Million standard cubic feet
MMscfd	Million standard cubic foot per day
MMtpy	Million tons per year
mol.	Molecular
MP	Medium pressure
MPFP	Medicine Bow Fuel and Power LLC
Mscf	Thousand standard cubic feet
MTBE	Methyl tertiary butyl ether
MTG	Methanol to gasoline
MW	Megawatts
MWh	Megawatt-hours
NAAQS	National Ambient Air Quality Standards
NCDC	National Climate Data Center
neg.	Negligible
NESHAPs	National Emission Standards for Hazardous Air Pollutants
NH <sub>3</sub>	Ammonia

## Acronyms

---

NH <sub>4</sub> NO <sub>3</sub>	Ammonium nitrate
(NH <sub>4</sub> ) <sub>2</sub> SO <sub>4</sub>	Ammonium sulfate
NO <sub>2</sub>	Nitrogen dioxide
NO <sub>3</sub>	Nitrate
NO <sub>x</sub>	Nitrogen oxides
NSCR	Non-selective catalyst reduction
NSPS	New Source Performance Standard
NSR	New Source Review
NWS	National Weather Service
ODEQ	Oregon Department of Environmental Quality
PBL	Planetary boundary layer
PM	Particulate matter
PM <sub>10</sub>	Particulate matter, less than 10 microns
ppmv	Parts per million by volume
ppmw	Parts per million by weight
PSD	Prevention of Significant Deterioration
psi	Pounds per square inch
psig	Pounds per square inch gauge
PTE	Potential to Emit
RACT	Reasonably Available Control Technology
RBL	RACT/BACT/LAER Clearinghouse
RH	Relative humidity
RICE	Reciprocating internal combustion engine
RMP	Risk Management Plan
RVP	Reid vapor pressure
SCCs	Source Classification Codes
scf	Standard cubic feet
SCFH	Standard cubic foot per hour
scm	Standard cubic meters
SCR	Selective Catalytic Reduction
SIC	Standard Industrial Classification
SILs	Significant Impact Levels
SIP	State Implementation Plan
SNCR	Selective Non-Catalytic Reduction
SO <sub>2</sub>	Sulfur dioxide
SO <sub>4</sub>	Sulfate
SOA	Secondary Organic Aerosol
SOCMI	Synthetic Organic Chemical Manufacturing Industry
SO <sub>x</sub>	Sulfur oxides
SRU	Sulfur Recovery Unit
SSM	Startup, shutdown, or malfunction
TANKS	U.S. Environmental Protection Agency Tanks Version 4.0
TBD	To be determined
TPD	Tons per day
tpy	Tons per year
UOP	UOP, LLC

## Acronyms

---

USGS	U.S. Geological Survey
USNPS	US National Park Service
UTM	Universal Transverse Mercator
VOC	Volatile organic compound
vol%	Volume percent
WAQS&R	Wyoming Air Quality Standards and Regulations
WDEQ	Wyoming Department of Environmental Quality
WRAP	Western Regional Air Partnership
wt%	Weight percent
yr	Year



## 1.1 GENERAL FACILITY DESCRIPTION

Medicine Bow Fuel & Power LLC (MBFP) is proposing to construct an underground coal mine (Mine) and industrial gasification & liquefaction (IGL) plant (Plant) that will produce transportation fuels and other products near Medicine Bow, Wyoming in Carbon County. The Mine will process approximately 8,000 tons per day (TPD) of coal (on a dry basis) to produce a variety of liquid and gaseous fuels. The Mine will be a 3.2 million ton per year (MMtpy) adjacent underground coal mine known as the Saddleback Hills Mine that will supply the coal needed for the Plant.

The Plant will utilize coal, which will be gasified to produce synthesis gas (syngas) and produce various products. In order to achieve this outcome, the Plant will use several different technologies, including: General Electric's (GE) gasification technology for the quench gasification process, UOP LLC's (UOP) SELEXOL<sup>®</sup> acid gas removal process, and Davy Process Technology's (Davy) methanol synthesis process followed by the Exxon-Mobil methanol-to-gasoline (MTG) process.

Saleable products produced at the Plant during normal operation are anticipated to include approximately:

- 18,500 barrels per day (BPD) of regular gasoline to be transferred via pipeline to a nearby refinery
- 42 TPD of sulfur
- 198 million standard cubic feet per day (MMscfd) of carbon dioxide (CO<sub>2</sub>)
- 712 TPD of coarse slag

In addition to the salable products listed above, Plant operation will result in the production of the following fuels to be used onsite for power generation and process heating:

- Approximately 253 million British thermal units (MMBtu/hr) of fuel gas
- Approximately 400 to 500 MMBtu/hr of liquefied petroleum gas (LPG)

Efficient use of these fuels will provide much of the energy input needed to fuel an electric generation plant that will produce approximately 400 megawatts (MW) of electricity. The Plant will either import natural gas or divert syngas as necessary to support plant power needs not met by fuel gas, LPG, and process steam and is not expected to export power to the electrical grid. Three combustion turbines will be equipped with the best available pollution control technologies, which include low-NO<sub>x</sub> burners, diluent injection, selective catalytic reduction (SCR), and oxidation catalyst to keep criteria pollutant emissions low.

Emission reduction technologies will be incorporated throughout the Plant. These controls are discussed in more detail in Sections 2 and 4. In addition, all roads and parking areas within the Plant fence will be either gravel or paved to control fugitive dust emissions.

This amended Prevention of Significant Deterioration (PSD) permit application contains fully updated information based on replacement of the previously planned Fischer-Tropsch and UOP upgrading processes with the Davy methanol synthesis unit and Exxon-Mobil MTG processes. This process change affects many process streams and emission calculations. Consequently, a

complete amended permit application is being submitted. This permit application contains information describing the Mine and Plant, facility emissions, applicable regulations, best available control technology (BACT) determinations, and air quality impact analyses. Wyoming Air Quality Permit Application Forms are included in Appendix A.

## 1.2 FACILITY LOCATION

The Mine and Plant (collectively, the MBFP Facility) will be located approximately 7.5 miles north of Interstate 80, exit 260 (Elk Mountain) on County Road #3 in Section 29 of Township 21 north and Range 79 west in Carbon County, south-central Wyoming. Figure 1.1 shows the general location of the facility. The MBFP Facility encompasses two separate areas. The Mine's South Portal is shown in Figure 1.2. The Mine's East Portal, near where the Plant will be located, is shown in Figure 1.3. Figure 1.4 shows the Plant process equipment layout.

## 1.3 PREVENTION OF SIGNIFICANT DETERIORATION APPLICABILITY

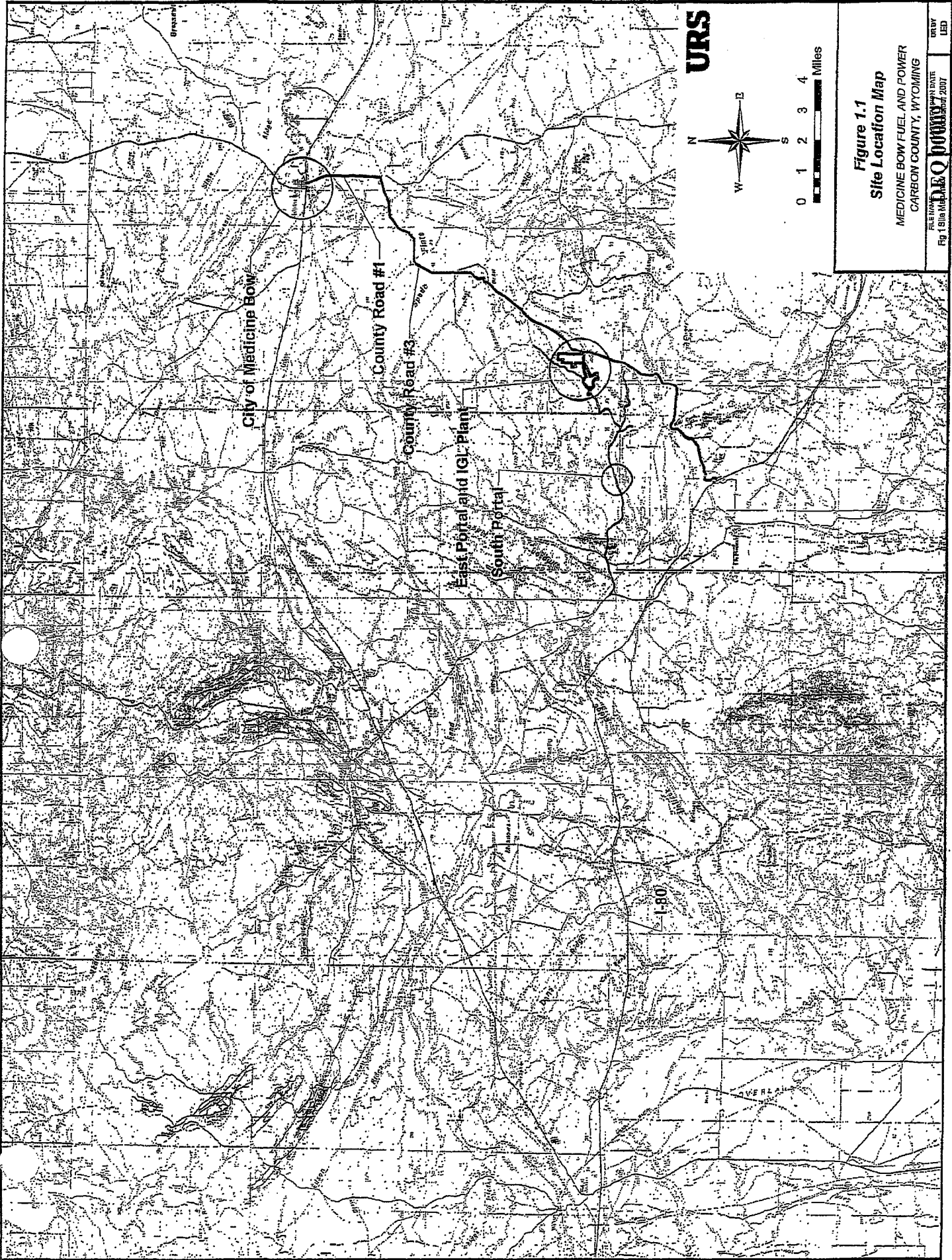
The Clean Air Act (CAA) defines 28 major source categories that have a 100 ton per year (tpy) threshold for determining prevention of significant deterioration (PSD) major source status. This facility falls within the major source category of "Fuel Conversion Plant," and therefore is subject to the 100 tpy major source threshold. Annual emissions of criteria pollutant emissions are shown in Table 1.1 for normal operations without startup, shutdown, and malfunction (SSM) events. Estimates of the following pollutants are included: NO<sub>x</sub> (nitrogen oxides, including nitrogen dioxide [NO<sub>2</sub>]), carbon monoxide (CO), volatile organic compounds (VOC), and particulate matter with a diameter of less than 10 microns (PM<sub>10</sub>). Emission calculation methods are summarized in Section 3 and detailed emission calculations are included in Appendix B.

Table 1.1 – Annual Criteria Pollutant Emissions (tpy)

NO <sub>x</sub>	CO	VOC	SO <sub>2</sub>	PM <sub>10</sub>
233.80	146.80	198.33	32.46	192.34

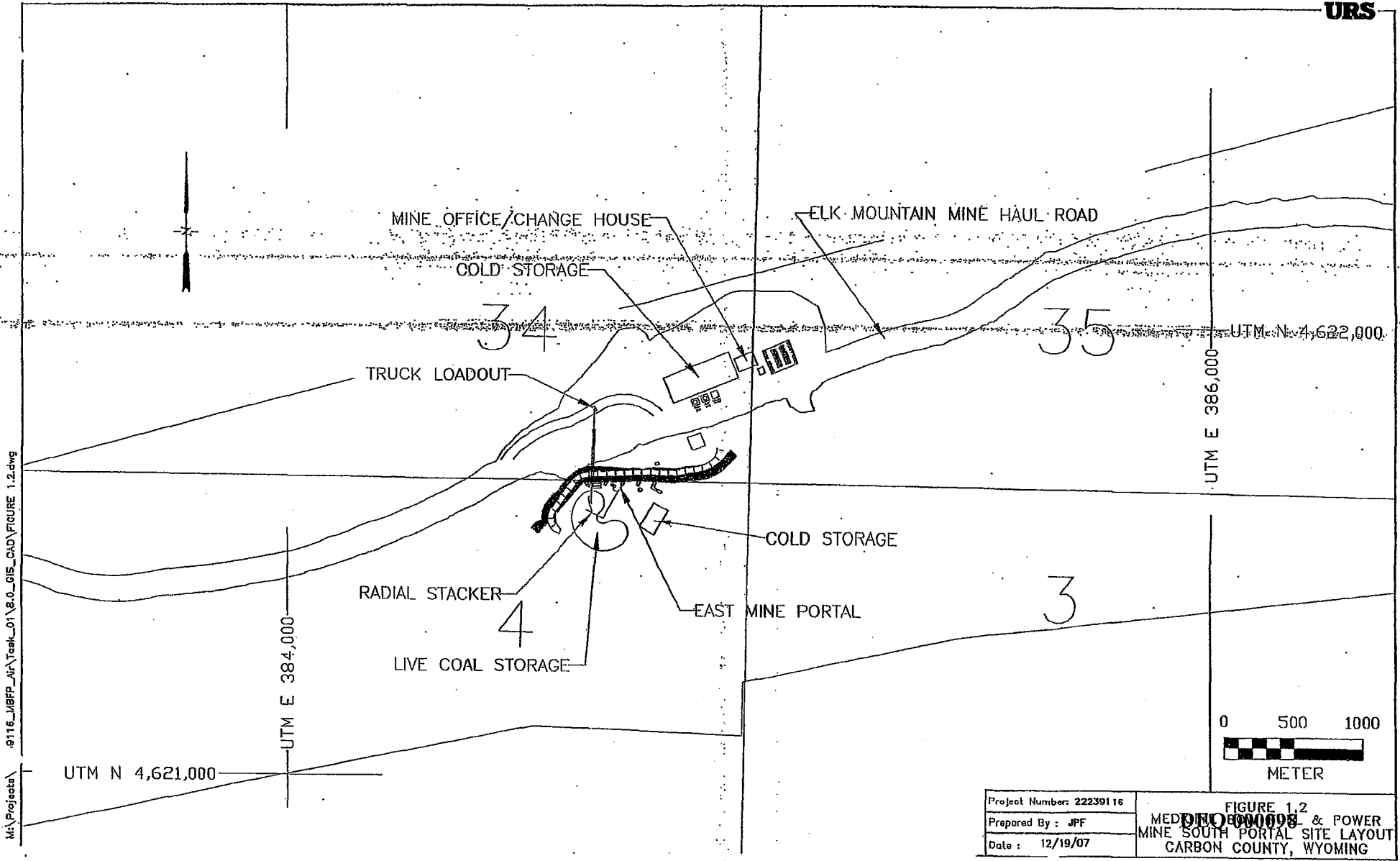
Based on criteria pollutant emissions, this facility is considered to be a major source for the PSD Program (40 CFR §51.165) and the Title V Operating Permit Program (40 CFR Part 70).

Annual emissions of hazardous air pollutant (HAP) emissions from normal operations are shown in Table 1.2. HAPs with emissions greater than 0.01 tpy are included in the table. Because potential emissions of total HAPs exceed 25 tpy, the facility is a major source of HAPs and is subject to some National Emission Standards for Hazardous Air Pollutants (NESHAP) in 40 CFR Parts 61 and 63.



**Figure 1.1**  
**Site Location Map**  
 MEDICINE BOW FUEL AND POWER  
 CARBON COUNTY, WYOMING

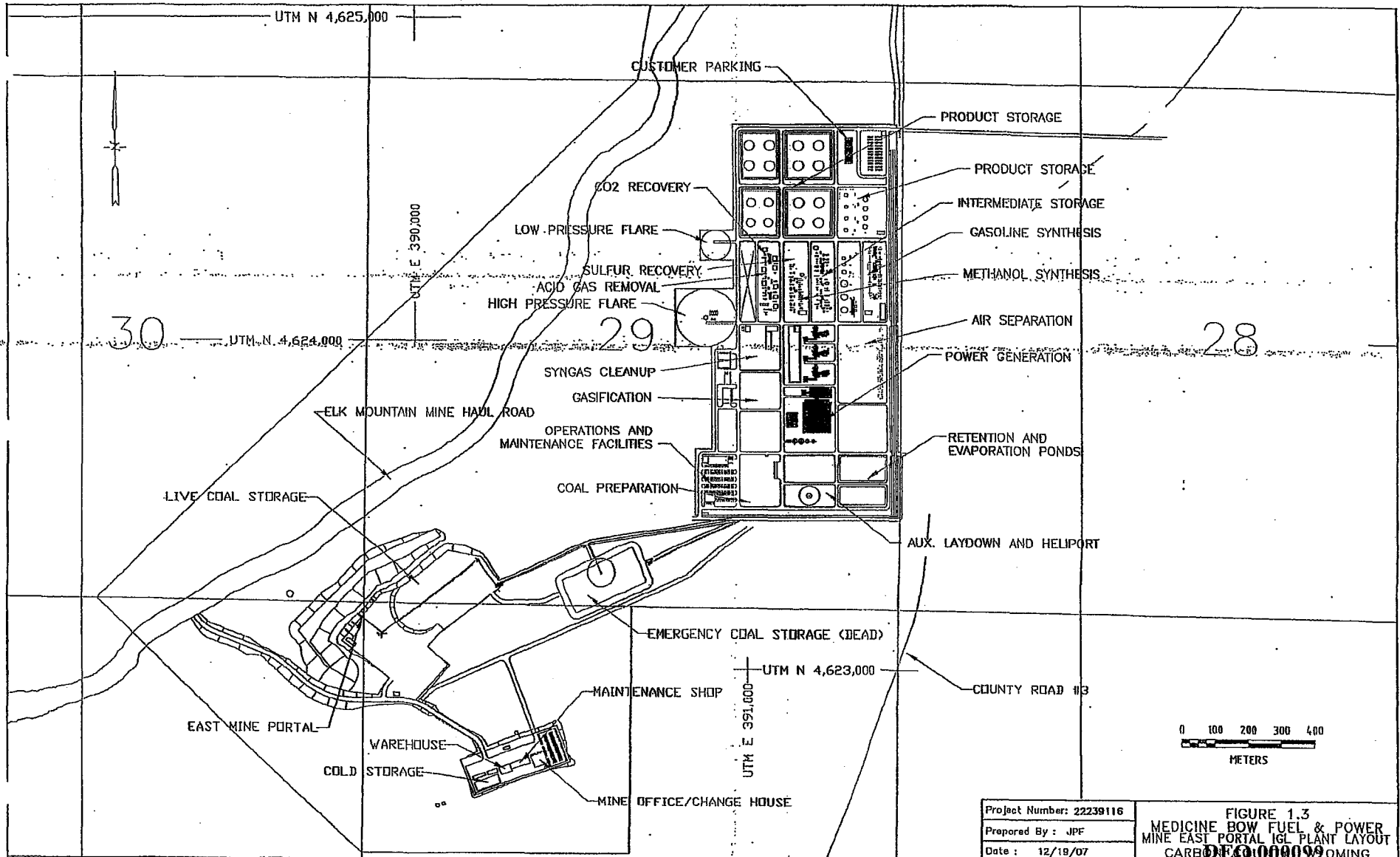
FILE NAME: **DEVELOPMENT**  
 PRINT DATE: **11/15/2007**  
 DRAWN BY: **LED**



M:\Projects\9116\_MBFP\_MrTask\_01\6.0\_GIS\_CAD\FIGURE 1.2.dwg

Project Number:	22239116
Prepared By:	JPF
Date:	12/19/07

FIGURE 1.2  
 MEDICAL & POWER  
 MINE SOUTH PORTAL SITE LAYOUT  
 CARBON COUNTY, WYOMING



Project Number: 22239116  
 Prepared By: JPF  
 Date: 12/19/07

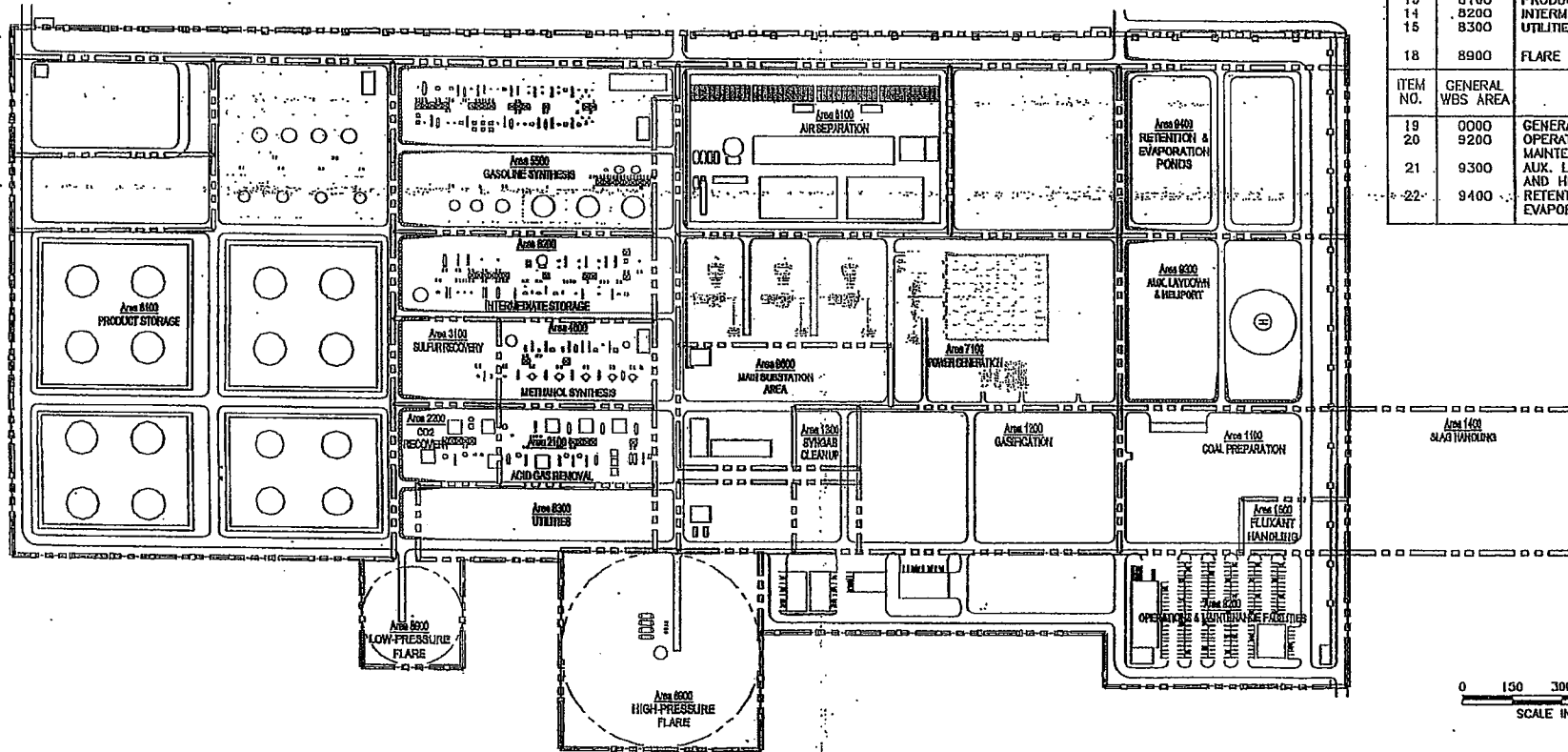
**FIGURE 1.3**  
**MEDICINE BOW FUEL & POWER**  
**MINE EAST PORTAL IGL PLANT LAYOUT**  
 CARBON DIOXIDE REMOVAL

M:\Projects\22239116\_MBFF\_Air\Task\_01\8.0\_GIS\_CAD\FIGURE 1.4.dwg

URS

DEQ 000100

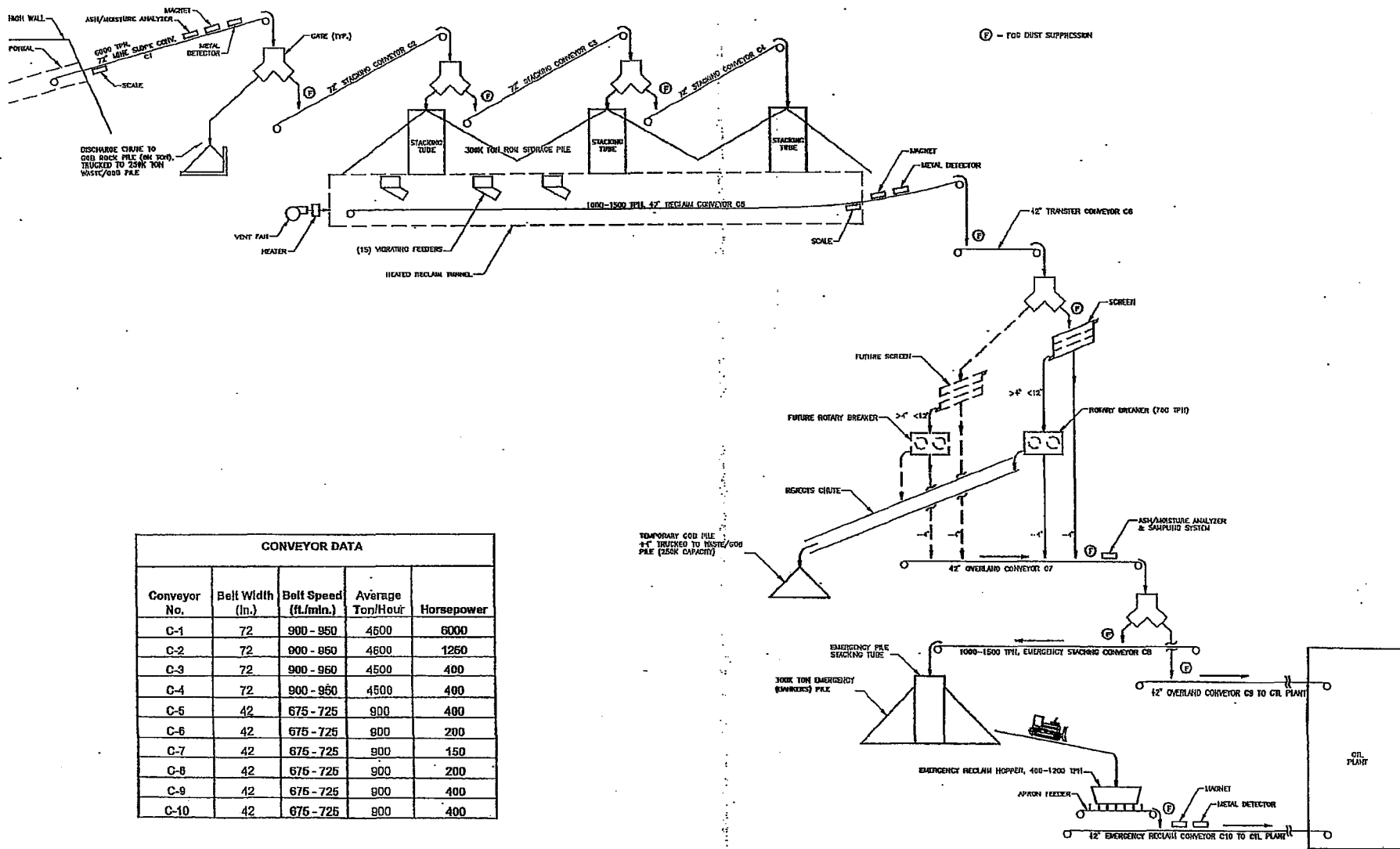
ITEM NO.	UNIT WBS AREA	DESCRIPTION
1	1100	COAL PREPARATION
2	1200	GASIFICATION
3	1300	SYNGAS CLEANUP
4	1400	SLAG HANDLING
5	1500	FLUXANT HANDLING
6	2100	ACID GAS REMOVAL
7	2200	CO <sub>2</sub> RECOVERY
8	3100	SULFUR RECOVERY
9	4600	METHANOL SYNTHESIS
10	5500	GASOLINE SYNTHESIS
11	6100	AIR SEPARATION
12	7100	POWER GENERATION
13	8100	PRODUCT STORAGE
14	8200	INTERMEDIATE STORAGE
15	8300	UTILITIES
18	8900	FLARE
ITEM NO.	GENERAL WBS AREA	DESCRIPTION
19	0000	GENERAL OPERATIONS AND MAINTENANCE FACILITIES
20	9200	AUX. LAYDOWN AREA AND HELIPORT
21	9300	AUX. LAYDOWN AREA AND HELIPORT
22	9400	RETENTION AND EVAPORATION PONDS



Job No. : 22239116  
 Prepared By : SJL  
 Date : 12/18/07

FIGURE 1.4  
 MEDICINE BOW FUEL & POWER  
 PROCESS EQUIPMENT LAYOUT  
 DRAWING INDEX / WBS INDEX

M:\Projects\22239116\_MBF\_P\_Air\_Task\_01\8.0\_GIS\_CAD\FIGURE 2.2.dwg



CONVEYOR DATA				
Conveyor No.	Belt Width (In.)	Belt Speed (ft./min.)	Average Ton/Hour	Horsepower
C-1	72	900 - 950	4500	6000
C-2	72	900 - 950	4500	1250
C-3	72	900 - 950	4500	400
C-4	72	900 - 950	4500	400
C-5	42	675 - 725	900	400
C-6	42	675 - 725	900	200
C-7	42	675 - 725	900	150
C-8	42	675 - 725	900	200
C-9	42	675 - 725	900	400
C-10	42	675 - 725	900	400

<p>SOURCE OF DRAWING</p>  <p><b>ROBERTS &amp; SCHAEFER</b> Company ENGINEERS AND CONTRACTORS CHICAGO - SALT LAKE CITY</p>	<p>Job No. : 22239116</p>
	<p>Prepared by : SJL</p>
	<p>Date : 12/19/07</p>

FIGURE 2.2  
MEDICINE BOW FUEL & POWER  
COAL MINE PROCESS FLOW DIAGRAM  
CARBON COUNTY, WYOMING

Table 1.2 – Annual HAP Emissions (tpy)

Pollutant	Emissions (tpy)
Acetaldehyde	0.38
Acrolein	0.06
Benzene	11.08
Carbonyl Sulfide	0.26
Ethyl Benzene	0.34
Formaldehyde	0.71
Hexane	0.73
Methanol	12.79
Naphthalene	0.01
PAH	0.02
Propylene Oxide	0.28
Toluene	1.81
Xylene	0.77
Other HAPs*	0.01
<b>Total HAPs</b>	<b>29.24</b>

\*Other individual HAPs are less than 0.01 tpy each.

#### 1.4 STANDARD INDUSTRIAL CLASSIFICATION

Two Standard Industrial Classification (SIC) Codes describe the activities associated with the MBFP Facility. These include:

1. 1222 Bituminous Coal Underground Mining
2. 1311 Crude Petroleum and Natural Gas (production of gas and hydrocarbon liquids through gasification)

Because the primary purpose, and source of revenue of the facility is to produce gasoline fuel, the main SIC code will be 1311.



This section describes the coal mining and industrial production processes. Because coal mining is common in the area, the coal mining description is relatively short. Due to its relative newness and complexity, the Plant is described in much more detail; Figure 2.1 illustrates the process.

## 2.1 COAL MINING

The Mine will produce approximately 3.2 MMtpy of coal using underground continuous and longwall mining techniques. Longwall mining machines consist of multiple coal shearers mounted on a series of self-advancing hydraulic ceiling supports. Longwall mining machines are about 800 feet in width and 5 to 10 feet tall. Longwall miners extract "panels", rectangular blocks of coal, as wide as the mining machinery and as long as 12,000 feet. The shearers cut coal from a wall face, which falls onto a conveyor belt for removal. As a longwall miner advances along a panel, the roof behind the miner's path is allowed to collapse.

The mined coal will exit the mine via the East Portal. The coal will be conveyed and stored in a 300,000-ton live storage area before being conveyed to the Plant. Coal handling conveyors will be fully enclosed, and all transfer points are fogged to reduce emissions. An additional 300,000-ton emergency coal stockpile will be constructed. This emergency coal stockpile is considered dead storage and will not be added to or used unless the coal supply for the live storage is interrupted. Once the emergency stockpile is constructed, it will be compacted and sealed to prevent wind erosion and spontaneous combustion.

Figure 2.2 shows the above-ground coal handling process for stacking the coal and transferring it to the Plant.

## 2.2 GASOLINE PRODUCTION

Figure 2.1 contains a block flow diagram illustrating the Plant production process and associated support activities. Major processes required to produce gasoline are described in this section. Additional production steps for removing CO<sub>2</sub> and sulfur products are described in Sections 2.3 and 2.4, respectively. Ancillary operations, such as power generation, wastewater treatment, and other activities are described in Section 2.5.

### 2.2.1 Coal Preparation (1100)

The Plant process begins with coal feed preparation, shown on the left side of the process block flow diagram in Figure 2.2. Raw feed coal (run of mine) from the coal storage area is routed via an enclosed conveyor to the coal crusher. The crushed coal is screened to a maximum size of 1 inch, with oversized coal recycled back to the crusher. All transfer points are fogged to reduce emissions. The crushed and screened coal is conveyed and stored in three bins and is gravity flowed to the coal-grinding mill.

The coal is crushed with water and an additive to create a slurry, which will be pumped into the gasifier under high pressure. The coal preparation process is divided into three separate trains, each with the capacity to supply 40% of the total plant requirements. The slurry produced by any of the trains can be pumped to any of the five (5) downstream gasification trains. The coal preparation section provides a total of 8,700 tons per day (TPD) of coal to the gasifiers (wet basis); this is equivalent to 8,000 TPD of coal on a dry basis.

Drainage, wash down, and leaks in the grinding area are collected in a below-grade concrete sump. An agitator keeps the solids in suspension for pumping. Any accumulated water/solids mixture is pumped to the slurry tank.

### **2.2.2 Gasification (1200)**

The Plant will utilize five (5) gasifier trains. Each gasifier train will be sized to handle one-fourth of the Plant's total capacity. In normal operation, four gasifier trains will be in operation with the fifth in hot standby. The gasifiers are fueled by a coal/water slurry, calcium carbonate ( $\text{CaCO}_3$ ), and 98 percent pure oxygen from the air separation unit (ASU).

The gasification reaction is conducted at a pressure of 1,000 psig and generates a temperature of approximately 2,500 degrees Fahrenheit ( $^{\circ}\text{F}$ ). The combustion chamber is lined with refractory bricks, which maintain the outer shell of the gasifier in a temperature range of 545 $^{\circ}\text{F}$  to 600 $^{\circ}\text{F}$ . Each gasifier is equipped with a dedicated preheater (Gasifier Preheaters 1 through 5). During the initial gasifier startup, and during any subsequent startup following refractory replacement, the gasifier preheater combusts natural gas and slowly heats the refractory to achieve the minimum temperature needed for combustion chamber operation. Each preheater has a firing rate of 21 MMBtu/hr and is fueled with natural gas.

Combustion products of the gasification reaction consist of raw syngas, together with small amounts of a number of impurities (including chlorides, sulfides, nitrogen, argon, and methane), liquid slag, and fine solid particles. These combustion products exit the combustion chamber and flow to a quench chamber where the combustion products are cooled and most of the particle fines are removed from the syngas. The molten slag solidifies and settles to the bottom of the chamber. If necessary, calcium carbonate can be added to the coal slurry as a fluxant to facilitate free flow of the molten slag in the gasifier. Solidified coarse slag is removed from the gasifier through a lock hopper system connected to the bottom of the quench chamber, and this stream sweeps the solidified slag through a slag crusher. The crushed slag is then recycled and reused or disposed. Approximately 980 TPD of slag will be produced and approximately 712 TPD of slag will be available for sale; the remainder is recycled to the slurry because of its Btu content. The syngas exits the gasifier through a side connection.

During any startup, shutdown, or malfunction (SSM) event, the syngas will be sent to the high-pressure flare. The syngas feed to the flare is expected to have a heat rate of approximately 2,000 Btu/lb.

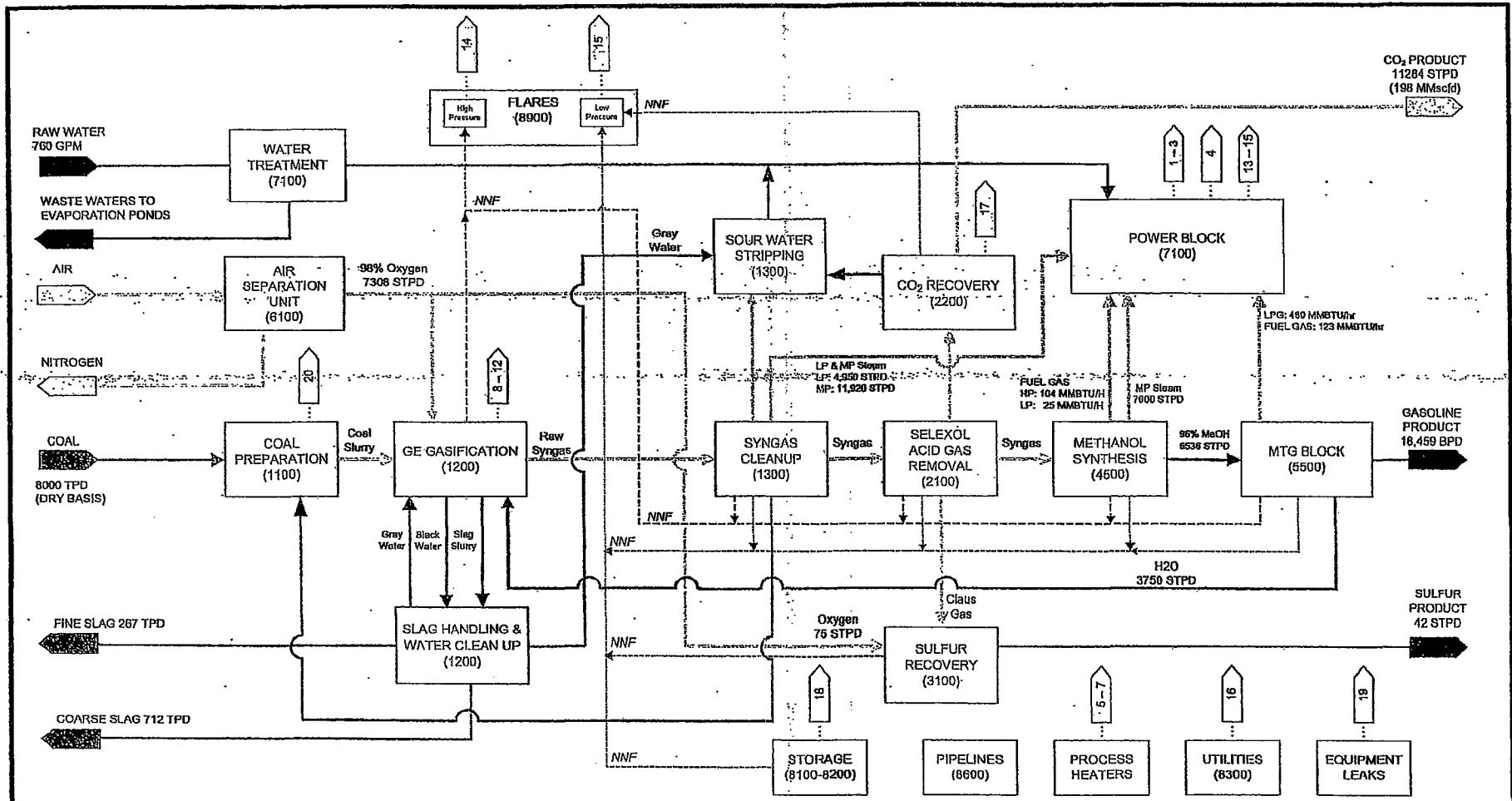
### **2.2.3 Syngas Conditioning (1300)**

Syngas conditioning includes two main treatment processes:

- Scrubbing to remove particulate from the syngas
- Low-temperature gas cleanup (LTGC)

#### **2.2.3.1 Syngas Scrubbing**

The Plant includes five (5) syngas conditioning trains, each sized for one-fourth of plant capacity. Each syngas conditioning train is integrated with a specific gasifier, with four (4) such



CO<sub>2</sub> PRODUCT  
11284 STPD  
(198 MMscfd)

GASOLINE PRODUCT  
18,459 BPD

SULFUR PRODUCT  
42 STPD

**ACRONYMS**  
 BPD Barrels per day  
 HGT Heavy gasoline treatment  
 MMscfd Million standard cubic feet per day  
 MTG Methanol to gasoline  
 NNF Normally flow  
 STPD Standard tons per day

**LEGEND**  
 [Symbol] Gas  
 [Symbol] Liquid  
 [Symbol] Solid  
 [Symbol] Energy (Steam or Fuel)  
 [Symbol] High Pressure Vent Stream  
 [Symbol] Low Pressure Vent Stream  
 [Symbol] Stack or Fugitive Emission

ID No.	Description	ID No.	Description
1-3	Combustion Turbines (3)	14	High Pressure Flare
4	Auxiliary Boiler	15	Low Pressure Flare
5	Catalyst Regenerator Heater	16	Flowmeter Pump
6	Reactivation Heater	17	CO <sub>2</sub> Vent
7	HGT Reactor Charge Heater	18	Storage Tanks
8-12	Gasifier Preheaters (5)	19	Equipment Leaks
13-15	Black Start Generators (3)	20	Coal Storage

**Figure 2.1**  
 Medicine Bow Fuel & Power  
 Plant Process Block Flow Diagram

SCALE:	JOB NO.:	DWG. NO.:	REV.:
		850-00018	
			SHEET

**URS** URS Corporation

DEQ 000105

trains operating and the fifth acting as a spare during normal operations. This description refers to one syngas conditioning train only.

Raw syngas leaves the gasifier and is mixed with process condensate in the process line to prevent the buildup of solids and thoroughly wet the entrained solids to facilitate their removal in the syngas scrubber.

The syngas scrubber is a tower that contains a water sump in the bottom and four trays in the top. Wet syngas enters the scrubber below the first tray and flows downward into the water sump, which removes most of the solids in the gas, and then flows upward through the four trays. Process condensate is supplied to the top tray and flows downward, counter-currently washing the remaining solids from the syngas. From the scrubber trays, a de-mister removes any entrained water droplets, such that an essentially particulate-free syngas exits from the top of the syngas scrubber.

### 2.2.3.2 Low-Temperature Gas Cleanup

The low-temperature gas cleanup (LTGC) Unit is a single system sized for 100 percent of plant capacity. The two main purposes of this system are to:

- Cool the raw syngas while producing steam; and
- Provide other gas cleanup functions, including carbonyl sulfide (COS) hydrolysis and water gas shift.

The LTGC unit receives syngas from the four (4) operating syngas scrubber trains. The syngas is then cooled in a series of two exchangers [the Syngas Interchanger against reheating treated syngas from the SELEXOL<sup>®</sup> unit and the low pressure (LP) steam generator which produces LP steam]. The resulting partly condensed syngas is separated, and the condensate is pumped into the return condensate stream.

After the separation, the syngas is heated to 400°F with medium pressure (MP) steam and split into two streams. The syngas either enters a water shift reactor which converts CO and H<sub>2</sub>O to CO<sub>2</sub> and H<sub>2</sub> and hydrolyzes COS or enters a reactor where COS is hydrolyzed to hydrogen sulfide (H<sub>2</sub>S) and CO<sub>2</sub>. The flows are balanced to adjust the H<sub>2</sub> to CO ratio of the syngas for optimal methanol synthesis. The two streams are then cooled in a series of two exchangers before entering knock-out drums. Syngas in the overhead vapor streams is routed to the SELEXOL<sup>®</sup> Acid Gas Removal Unit as a shifted and unshifted syngas stream.

The condensate from the LTGC area flows to a stripper, which also receives the condensate streams from the gasification system. The stripper removes almost all of the ammonia (NH<sub>3</sub>), H<sub>2</sub>S, and COS from the condensate, along with some dissolved hydrogen (H<sub>2</sub>) and CO. The stripper overhead gas is blended with sour flash gases from the flash separators and compressed before going to the SELEXOL<sup>®</sup> Unit, so that the H<sub>2</sub> and CO can be recovered from the sour gas. The stripper bottoms water is returned to the syngas scrubber.

**2.2.4 SELEXOL® Acid Gas Removal (2100)**

The SELEXOL® process, licensed by UOP, has been selected as the acid gas removal technology. Two SELEXOL® process trains will provide the following functions for the shifted and unshifted streams:

- Removal of sulfur compounds (H<sub>2</sub>S and COS) from the syngas to a level acceptable to the downstream Methanol Synthesis Unit,
- Recovery of most of the CO<sub>2</sub> in the syngas for further purification, and
- Recovery of a concentrated H<sub>2</sub>S/COS stream to be sent to the Sulfur Recovery Unit (SRU).

The quenched sour syngas from the Syngas Conditioning Unit enters a mercury removal bed, and then is mixed with recycled stripped gas and flows to the SELEXOL® Feed/Product Exchanger to cool the feed gas against treated syngas and enhance the efficiency of absorption. The cooled feed gas flows through two successive absorbers; the first absorber removes H<sub>2</sub>S and the second absorber removes CO<sub>2</sub>. In each absorber, the syngas enters at the bottom of a packed bed and flows upward through the bed where it contacts cool solvent entering the top of the tower. In these absorbers, H<sub>2</sub>S, COS, CO<sub>2</sub>, and other gases such as H<sub>2</sub>, are transferred from the gas phase to the liquid phase. The treated gas passes through de-entrainment devices at the top of the absorbers, as well as three water wash trays to minimize solvent carry-over. The treated syngas exits the top of the CO<sub>2</sub> absorber and is sent to the downstream Methanol Synthesis Unit.

Treated syngas leaving the SELEXOL® Unit is expected to contain less than 0.1 parts per million by volume (ppmv) total sulfur. Further sulfur reduction through the use of sulfur beds is required to protect the catalyst in the downstream Methanol Synthesis Unit from poisoning and the risk of sulfur spikes that could be caused by SELEXOL® Unit upsets. Each of the parallel beds is sized for full plant capacity. For best performance, the syngas is heated to 400°F before entering the guard bed.

The syngas from the guard beds is then sent to a compressor, where the syngas pressure is increased to the levels required in the Methanol Synthesis Unit. The syngas is then sent to the Methanol Synthesis Unit.

The SELEXOL® solvent from the H<sub>2</sub>S Absorber is regenerated by stripping out less soluble gases, such as CO<sub>2</sub>, H<sub>2</sub>, and CO. The partially regenerated SELEXOL® solvent then flows to an H<sub>2</sub>S stripper, where the remaining H<sub>2</sub>S, CO<sub>2</sub>, N<sub>2</sub>, and other compounds are transferred from the liquid phase to the gas phase by contact with steam. The steam and liberated gases exit the stripper, and then flow upward through a demister and into the trayed section of the column. In the trayed section, the rising gas is contacted with counter-current flowing reflux water to cool and partially condense the hot overhead vapor, as well as reduce solvent entrainment. The overhead stream passes through a de-entrainment device and exits the top of the column. The overhead gas then passes through a condenser in order to condense and recover a portion of the overhead steam. The liquid and vapor phases are separated; the H<sub>2</sub>S-rich acid gas exits the unit battery limits and is sent to the SRU, and the liquid is returned to the trayed section of the H<sub>2</sub>S stripper.

**2.2.5 Methanol Synthesis (4500)**

Methanol is produced from synthesis gas using a highly selective copper-based catalyst. These reactions are exothermic and occur at a temperature suitable for generating medium pressure steam. Efficient use of waste heat from the methanol synthesis process is important for overall plant economics.

The Plant will use the licensed Davy Process Technologies methanol synthesis process. Major components of this process include:

- Syngas compression
- Syngas purification
- Methanol conversion

Particulate- and acid gas-free syngas is compressed and preheated before entering the Syngas Purification Vessel, which removes any remaining low levels of impurities that could potentially poison the methanol synthesis catalyst.

Feed gas from the Syngas Purification Vessel enters the first Methanol Converters, where it flows over methanol synthesis catalyst. On leaving the reactor, the gas mixture is cooled and methanol and water condense out. The remaining gas is compressed and mixed with incoming compressed syngas and recycled through the methanol converters. A small purge is taken from recirculated gas to control the level of inerts in the loop. Part or all of this gas undergoes hydrogen recovery, while the remainder is used as high-pressure fuel gas. The crude methanol is reduced in pressure to flash off the dissolved gases, mainly CO<sub>2</sub>. The off gases are sent to the power block as fuel gas. During normal operation, the crude methanol flows to the MTG unit. However, if the MTG unit is offline, methanol production can continue and be sent to intermediate storage.

**2.2.6 Methanol to Gasoline (5500)**

The Exxon-Mobil MTG process will convert methanol exiting the Methanol Synthesis Unit to approximately 18,500 BPD of high-octane gasoline. Hydrocarbons produced during the process are mainly in the gasoline boiling range (C<sub>5</sub>+ to 412°F) with a lesser amount in the C<sub>1</sub>-C<sub>4</sub> range. The process also produces a small amount of carbon oxides, a very small amount of oxygenates and coke, and a very large quantity of water. The following discussion summarizes the MTG process.

The chemistry of methanol conversion is complex. First, methanol is partially dehydrated using an alumina catalyst to an equilibrium mixture of methanol, dimethyl ether (DME), and water. Then, methanol and DME undergo a series of dehydration reactions in the MTG reactors forming light alkenes. Light alkenes oligomerize (i.e., undergoing chain growth by joining two or more alkene molecules together) and cyclise to give the final products.

One hydrocarbon produced of particular note is durene (1, 2, 4, 5-tetramethyl benzene), which is produced in greater amounts than is suitable for gasoline (unless the high-durene gasoline is blended with gasoline containing lower durene concentrations). The MTG process contains a step (Heavy Gasoline Treatment) to reduce the durene to suitable levels.

The MTG catalyst deactivates slowly due to coke deposits. Coke must be removed periodically by in situ combustion with air to restore catalyst activity. For this reason, five (5) parallel MTG reactors are provided. At any given time, one reactor will be off-line (either in regeneration or on stand-by) and the other reactors will be on-line (converting DME reactor effluent to hydrocarbons and water.)

The effluent from the MTG reactors is combined, cooled, and separated into three phases: gas, liquid water, and liquid hydrocarbon.

- **Gas Phase:** Most of the gas phase is recycled to the MTG reactor inlet. The remaining gas is purged to the plant's fuel gas system.
- **Liquid Water Phase:** The large volume of liquid water produced by the reactions contains about 0.1 weight-percent (wt%) oxygenates (alcohols, ketones, and acids).
- **Liquid Hydrocarbon Phase:** The liquid hydrocarbon phase from the MTG reactor is called raw MTG gasoline.

Raw MTG gasoline contains 3-6 wt% durene (1, 2, 4, 5-tetramethyl benzene) while commercial gasoline specifications typically require less than 2.0 wt% durene. A Heavy Gasoline Treatment (HGT) unit is provided to reduce the durene content to 2.0 wt%. The HGT unit fractionates raw MTG gasoline into two parts. One part is a small volume, heavy fraction with a high durene concentration; the other part is a large volume, light fraction.

The heavy fraction is heated using the HGT Reactor Charge Heater and hydrotreated in a fixed-bed reactor (the HGT reactor) to reduce its durene concentration. The hydrotreated heavy fraction is combined with the untreated light fraction to produce finished MTG gasoline meeting the durene specification.

#### **2.2.6.1 MTG Regeneration System**

During the conversion reaction in an MTG Reactor, coke forms slowly on the catalyst and reduces its activity. To restore catalyst activity, coke is periodically removed from the catalyst by controlled combustion with air, one reactor at a time.

For catalyst regeneration, one MTG Reactor is taken out of oil service and is isolated from the other reactors and hydrocarbons. After isolation, the reactor is depressurized to the HP flare. Hydrocarbon vapors are then removed from the reactor and are replaced with nitrogen. Regenerator gas consisting primarily of nitrogen is recycled and mixed with a controlled quantity of air. The hot gas flows to the MTG Reactor where coke on the catalyst is removed by controlled combustion. Regeneration flue gas leaves the reactor and is cooled and separated.

Following coke combustion, the reactor is again evacuated, purged with nitrogen, and filled with recycle gas. The reactor is brought back on-line by flowing recycle gas through the Reactivation Heater and then starting DME reactor effluent feed when the bed temperature is high enough to sustain reaction.

At an appropriate time, another MTG reactor is taken out of service for regeneration.

**2.2.6.2 MTG Water Treatment Unit**

The MTG water is processed to remove most organics and oxygenates so that it will meet GE specifications for process water recycle to the gasification unit.

The water from the MTG Unit is heated against hot stripped water in the Feed/Product Exchanger before entering the MTG Water Stripper. There, most of the oxygenates and any residual hydrocarbons are driven overhead as vapor. The stripper overhead is condensed by the air-cooled Stripper Overhead Condenser and the condensate is recovered in the Receiver. LP steam is used to drive the Stripper Reboiler. The aqueous stripper condensate, containing most of the oxygenates, is pumped from to the Power Block where it will be vaporized into one of the power plant fuel streams. Any insoluble organics are decanted in the Receiver and pumped to the slops system. Any trace non-condensables are sent to flare.

Because acetic acid and any heavier acids cannot be completely stripped from the water, provision is made for caustic injection into the stripper sump to neutralize the acids to ensure that the pH is above 5.5. The stripped, neutralized water from the bottom of the stripper is pumped by the Stripper Bottoms Pump, cooled in the Stripper Overhead Condenser against the feed water, and routed to one of the Gasification Units.

**2.2.6.3 LPG Processing Unit**

The MTG Process produces a significant LPG byproduct stream consisting of approximately 60 percent olefin and 40 percent paraffin materials. LPG average production is expected to be 27,171 lb/hr, which is approximately 3,380 BPD.

In the Plant's geographic area, LPG has no significant market value. Therefore, LPG will be used as in-plant fuel or a blending stock for RVP control. The RVP pressure specification changes month to month. Any LPG not used for RVP control will be used as fuel and can provide approximately 500 MMBtu/hr to the plant in summer. LPG fuel usage will reduce the quantity of natural gas or syngas used by the Plant.

**2.3 CO<sub>2</sub> RECOVERY (2200) AND PRODUCTION**

Under normal operations, a CO<sub>2</sub>-rich stream exits the SELEXOL<sup>®</sup> Unit. At this point in the process, the CO<sub>2</sub> contains less than 10 parts per million (ppm) total sulfur. The CO<sub>2</sub> flows into the CO<sub>2</sub> Recovery Unit, where it is compressed in one of three parallel four-stage centrifugal compressor trains and dried in a drying unit installed upstream of the third stage compressor suction. Some of the CO<sub>2</sub> is then refrigerated to provide liquid coolant to the Methanol Synthesis and SELEXOL<sup>®</sup> Units. The remaining CO<sub>2</sub> is ready for sale.

During startup, shutdown, and malfunction (SSM) events at the site, the CO<sub>2</sub> exiting the SELEXOL<sup>®</sup> Unit may be vented either because the CO<sub>2</sub> does not meet downstream specifications or because the site does not have sufficient power to start the CO<sub>2</sub> compression trains. This venting will occur through the CO<sub>2</sub> Vent Stack until the gas meets specifications and the compressors have been started, at which point no further emissions will occur from this stack.



## 2.4 SULFUR RECOVERY (3100) AND PRODUCTION

In the Sulfur Recovery Area, the H<sub>2</sub>S and COS in the acid gas from the SELEXOL<sup>®</sup> Unit is converted to elemental sulfur. After recovery of the sulfur, the non-sulfur portions of the Claus gas are treated to remove residual sulfur species.

The acid gas feed to the Sulfur Recovery Unit (SRU) is first washed with stripped sour water. The washed acid gas is then injected into a reaction furnace, where it is partially combusted with oxygen from the Air Separation Unit. The combustion products, which include sulfur, H<sub>2</sub>S, SO<sub>2</sub>, and CO<sub>2</sub>, are cooled in the waste heat boiler to produce MP steam, and then further cooled in a condenser, where elemental sulfur is condensed.

Since the reaction of H<sub>2</sub>S and SO<sub>2</sub> to produce sulfur is limited by equilibrium, the vapors from the first sulfur condenser are reheated against MP steam and reacted to form more sulfur over a special catalyst. These reaction products are once again cooled to condense more sulfur. To maximize the conversion of the sulfur species to elemental sulfur, two more subsequent stages of reheat, reaction and sulfur condensation are included. This is a three-stage Claus process, and about 42 TPD of sulfur will be produced and sold.

The raw sulfur recovered from the condensers flows as a liquid to a below-ground concrete pit. Since the raw sulfur contains dissolved H<sub>2</sub>S and other volatile sulfur species, a sulfur degassing system, including transfer pump, reaction vessel, and ejector is used to remove the volatiles. The purified sulfur is then pumped to liquid sulfur storage before being shipped as a liquid to the customer.

The unconverted gas from the last sulfur conversion stage (SRU tail gas) still contains about 5% of the sulfur in the feed acid gas, mostly COS and CS<sub>2</sub> that are difficult to convert to sulfur. To remove these sulfur species, the SRU tail gas passes through a hydrogenation reactor that reduces them to H<sub>2</sub>S. The reducing gas (hydrogen and CO) is produced by partially combusting fuel gas in the Reducing Gas Generator. The effluent from the reducing gas generator is cooled by generating LP steam, and then washed with water before proceeding to tail gas treatment.

The SRU tail gas is compressed and injected at the inlet of the SELEXOL H<sub>2</sub>S Stripper where it is combined with the SELEXOL H<sub>2</sub>S flash gas. During normal operation, the SRU tail gas will be recycled back to the SELEXOL<sup>®</sup> Unit. However, SRU tail gas will be routed to one of the flares in the event of a SELEXOL<sup>®</sup> or Claus unit upset. There are no continuous or intermittent purge gas streams from the SELEXOL<sup>®</sup> Unit.

When tail gas from the Claus units is routed to the SELEXOL<sup>®</sup> Unit, there are no vapor emissions to atmosphere from the SELEXOL<sup>®</sup> Unit. The following three vapor streams originate in the SELEXOL<sup>®</sup> Unit and flow to other plant areas:

- CO<sub>2</sub> product stream — The CO<sub>2</sub> product stream is compressed and sent to a pipeline customer. In an emergency or shutdown this stream may be vented; however, the stream is vented from the CO<sub>2</sub> recovery area, not from the SELEXOL<sup>®</sup> Unit.
- Claus gas stream — The Claus Gas is reacted to produce elemental sulfur, with any residual gas recycled to the SELEXOL<sup>®</sup> Unit. In an emergency or shutdown situation, the stack gas is vented from the sulfur plant area, not from the SELEXOL<sup>®</sup> Unit.
- Treated syngas — The treated syngas stream flows to the methanol synthesis area.

**2.5 ANCILLARY OPERATIONS****2.5.1 Power Generation (7100)**

The Power Block will consist of three parallel GE 7EA gas turbines normally fueled by a mixture of fuel gas, LPG, syngas, and natural gas that will produce approximately 185 MW in simple cycle mode at 100% firing rates at average normal operating annual ambient conditions. In addition, a heat recovery system on the gas turbine exhaust will superheat the medium pressure (MP) steam from the Methanol Synthesis area and the low pressure (LP) steam from the Syngas Conditioning area, and also produce and superheat HP steam. The superheated HP steam, MP steam and LP steam will then flow to a single, three-stage steam turbine, thereby producing approximately 215 MW of additional power, for a total nominal 400 MW.

If one of the three gas turbines is off-line, the two operating gas turbines with the heat recovery system would be capable of producing enough power to maintain the facility at full operating rates. Duct firing may be required in this scenario during summer operations. This operating flexibility is expected to considerably improve the overall availability of the Plant.

During the initial facility startup, power will be supplied by three, 1.6 MW Black Start Generators (Gen 1, 2 and 3). These generators will fire natural gas and will be operated until the Power Block can supply sufficient power.

**2.5.2 Air Separation Unit (6100)**

Two (2) identical air separation trains are provided, each of which will produce 3,700 short tons per day of 98 percent by volume (vol%) oxygen.

Atmospheric air is compressed to approximately 100 pounds per square inch absolute (psia) using an electric-driven compressor, treated to remove condensables, and fed to the air separation unit (ASU) where oxygen is separated cryogenically from atmospheric air. Following separation, the oxygen product with a purity of 98 vol% is pumped to high pressure as a cryogenic liquid and vaporized against a stream of condensing high pressure air within the ASU main heat exchanger. Almost all the gaseous oxygen product at 1,250 pounds per square inch gauge (psig) is fed as oxidant to the gasifiers. A small portion of the oxygen is let down in pressure and routed to the SRU, where it is used for sulfur production.

Since water is at a premium in the facility, ASU compressor intercooling and aftercooling is provided by a closed-loop, 66,000 gallons per minute (GPM) circulating glycol system, with heat rejection to the atmosphere by air-coolers.

A quantity of nitrogen is taken from the ASU and compressed for general plant usage, such as purging and tank inerting.

**2.5.3 Intermediate and Product Storage (8100-8200)**

Twelve (12) intermediate and product storage tanks will store large quantities of volatile materials. The largest of these storage tanks will include ten 150 ft diameter, 48 ft high, fully enclosed internal floating roof tanks. Two of these 150 ft diameter tanks will store methanol intermediate to provide some process buffering. The remaining eight of the largest tanks will store gasoline product, providing 60 days of product storage. An additional 130 ft diameter, 48

ft high tank will store heavy gasoline intermediate and a 7,000 gallon tank will store slops containing some volatile components.

Fifteen (15) additional small vessels will store the materials listed below.

- Liquid sulfur product
- Process water
- Additive
- Coolant
- Filtrate
- Glycol
- Liquid nitrogen
- Liquid oxygen
- LPG

#### **2.5.4 Slag Handling and Water Cleanup (1200)**

Slag slurry and black water from the Gasification Area enter the Slag Handling and Water Cleanup Area. The slag is dewatered using a flash system with hot water blowdown streams from the Gasifiers and Syngas Scrubber. The slag is conveyed to a stockpile where it will be loaded into trucks for offsite uses by others. There may be some slagscreening performed, as determined by customer demand. The slag is a vitreous (glass-like), high-density material and is not expected to become airborne. However, the stockpile will be kept wet as needed to prevent particulate emissions.

Gray water from the Water Cleanup system is routed to the Sour Water Stripper.

#### **2.5.5 Water Treatment (1300 and 7100)**

The Plant uses water for processing and as a heating and cooling medium in both liquid and steam phases. Raw water enters the Plant and is pumped to the Raw Water Tank located within the Power Block. From there, the raw water is filtered and processed by reverse osmosis (RO) and/or demineralizer units to produce the boiler feed water and the process water requirements of the overall facility.

The Plant is designed to be a zero-liquid process discharge facility. Water is re-used as much as possible and only a small portion of the total water with a high concentration of dissolved minerals flows to one of two evaporation ponds.

The brine concentrate from the RO system, along with gasification purge water, contain high concentrations of dissolved minerals such as sodium chloride. The combined reject water streams are sent to the steam-assisted evaporation pond within the Power Block, in which LP steam and solar energy are used to evaporate the residual water. The minerals are deposited in a layer at the bottom of the evaporation ponds, from which they may be eventually removed for off-site disposal.

Aqueous effluents (including gasification quench blowdown and steam generation blowdown) that cannot be recycled within the process areas will be sent to the Raw Water Processing Unit within the Power Block. If possible, this water will be re-used as substitute raw water feed, otherwise it will be sent to the Water Treatment Area for evaporation. The evaporation pond is sized to handle facility effluents and plant storm water runoff that has been through oil/water separation. Biological treatment of process water is not expected to be required.

### **2.5.6 Flares (8900)**

Two continuous pilot flare systems will be operated at the facility: a HP flare and a LP flare. The large HP flare will be designed to handle the largest flare loads, such as, for example, the total syngas flow from the gasifiers in the event that they must be isolated from the downstream units. The HP system will operate at a positive pressure to minimize the cost of piping and equipment. The smaller LP flare system will operate at close to atmospheric pressure and will handle smaller flare loads such as the MTG stripper vent emergency releases. Sections 3 (Emission Estimates) and 4 (BACT) include detailed information about the flares.

### **2.5.7 Other Utilities (8300)**

#### **2.5.7.1 Instrument Air / Plant Air**

Instrument air and plant air will be supplied by four (4) 50% capacity packaged units, one of which is powered by a generator in case of plant-wide power failure. No nitrogen backup for plant air is included. Each unit will supply 18,700 standard cubic feet per hour (SCFH) instrument air and 5,600 SCFH plant air. This system is included within the Power Block.

#### **2.5.7.2 Nitrogen**

Plant nitrogen for purging, tank inerting, and general plant purposes, as well as process nitrogen will be supplied from the ASU at 125 psig. A 10,000 gallon liquid nitrogen storage tank, with ambient air vaporizer, will be provided for backup supply and for startup service.

#### **2.5.7.3 Cooling**

All ambient temperature cooling is done, directly or indirectly, with air coolers.

#### **2.5.7.4 Natural Gas / Plant Fuel Gas**

Natural gas will be used for startup and as part of the fuel mix on an as-needed basis for the power generation system and process heaters.

## **2.6 STARTUP ACTIVITIES**

The first step in the startup process is to obtain the power required for energizing the critical control and safety systems. Power for initial startup of the gas turbines is provided by the three "black start" natural gas electric generators (Gen 1, Gen 2, and Gen 3), which will be used to provide power for approximately 1 week or less. Other key utility systems such as instrument

air, water supply and purification, fire water, and nitrogen will be made operational as required to start the first gas turbine. It is especially important that the flare system be ready for service before any flammable gas is present.

Once critical utilities are in service, one of the three gas turbines (Turbine 1-3) is started on pipeline quality natural gas. This will produce enough power to displace all of the black start generators, start the circulating glycol cooling system, start the auxiliary boiler circulation and gasification quench water system, and begin the startup of one of the ASUs. During normal operations, the turbine fuel will be a combination of natural gas, fuel gas, and LPG.

One of the two ASUs can be started up once adequate electric power is available. The circulating glycol cooling system must be in service before the ASU compressors can operate. From an initial warm condition, the ASU startup can take several days for cool down of the cold box equipment. When online, the ASU will initially produce enough oxygen to begin operation of two of the four (4) coal gasifiers needed for full-capacity operation. At this time, a second gas turbine is started up, also on natural gas, to provide enough power for full capacity operation of one ASU.

Before each gasifier can be started, the refractory in that gasifier must be heated. Refractory heating is accomplished using the natural gas-fired preheaters (Preheater 1-5) and takes approximately 500 hours per gasifier. Multiple gasifiers may be preheated simultaneously. In addition to completing the refractory heating, the plant quench water circulation must be in service, along with the sour water stripper and low temperature syngas cooling system before the startup of any gasifier. To start the first gasifier, the natural gas fired preheat burner is shut down, removed and replaced with the coal slurry feed injector. Coal slurry and oxygen are then fed to the injector to initiate the gasification of the coal. A second gasifier is then started up in the same manner as the first. By this time, the single ASU is operating at full rates and is producing enough oxygen to feed two (2) gasifiers. The initial raw syngas product is flared until the syngas conditioning unit is on-line, which is anticipated to take approximately 1 week during the initial startup.

Circulation of SELEXOL<sup>®</sup> solvent through the Acid Gas Removal System is commenced at this time. The refrigeration package must also be in operation to chill the solvent to operating temperature. Once the SELEXOL<sup>®</sup> unit is ready, and when the two gasifiers are in service at full operating pressure and temperature, the syngas is allowed to enter the SELEXOL<sup>®</sup> unit. The CO<sub>2</sub> recovered by the SELEXOL<sup>®</sup> unit is initially vented (CO<sub>2</sub> Stack) until the CO<sub>2</sub> meets pipeline specifications, which may take some days. The desulfurized syngas from the SELEXOL<sup>®</sup> unit is flared until the methanol synthesis unit is ready to receive feed. During the cold start there will be a brief period (anticipated to be approximately 10 hours) where off-spec gas may be flared.

After the SELEXOL<sup>®</sup> unit is in service, the gasifier system operation is adjusted if necessary to make syngas of the proper composition so that, after acid gas removal, the syngas is an acceptable feed for the Methanol Synthesis Unit.

The SRU can be started up once a sufficient flow of sulfur-rich acid gas (Claus Gas) is available from the SELEXOL<sup>®</sup> unit. Once desulfurized syngas that meets the Methanol Synthesis Unit specifications is available, the methanol synthesis unit can be started up to produce methanol which is routed to an intermediate storage tank. Once methanol of sufficient quantity is available to assure startup of the methanol to gasoline (MTG) unit, the MTG unit will convert methanol to

## **SECTION TWO**

## **Process Description**

---

hydrocarbons (primarily gasoline) and water in fixed-bed reactors. Methanol is then converted to an equilibrium mixture in the DME reactor. The effluent from the DME reactor is then combined with recycled gas and converted to gasoline and water through the MTG reactors. The MTG reactor effluent is collected and separated into three phases. (1) A portion of the gas phase is recycled with the remaining gas being sent to the plant fuel gas system. (2) The liquid water phase produces water which is recycled into the gasifier unit, and (3) The liquid hydrocarbon phase becomes raw MTG gasoline. Following hydrotreating, the facility produces finished gasoline, LPG and fuel gas of high quality.

When MP steam is available in adequate quantity from the syngas cooldown and methanol unit, the MP steam is routed through the gas turbine superheat coils, permitting the steam turbine to be started up to produce additional power. The flow to the steam turbine is augmented by LP steam from gasification low temperature syngas cooling.

**3.1 SADDLEBACK HILLS MINE**

Originally Arch of Wyoming LLC (subsidiary of Arch Coal, Inc.) permitted the Mine (underground) and the Elk Mountain (surface) Mines together under one air quality permit (Permit # CT-4136). The combined facilities were known as the Carbon Basin Mines. Arch Coal has entered into an option agreement to sell the underground coal reserve and surface real property to MBFP. Once MBFP exercises this option, Arch Coal has retained the rights to operate the Elk Mountain Mine and market the surface coal. As a result of this agreement, a determination was made by the Wyoming Department of Environmental Quality (WDEQ)/Air Quality Division (AQD) that the Saddleback Hills Mine was considered a support activity under the definition of a facility and should be included in the MBFP PSD application.

During the underground mine's development phase, approximately 2.1 million tons of coal will need to be mined over a 3-year period. The development phase constructs the underground infrastructure required to support the longwall mining system which will commence operations at approximately the time when the Plant achieves full capacity. During the development or construction phase of the mine, coal will be conveyed from the South Portal where it will be stored in a small stockpile. It is anticipated that this production will then be placed in the designated long term storage stockpile. Should there be excess production during the development phase, coal may then be loaded into trucks at the South portal and hauled to the Seminole II train loadout in Hanna, Wyoming.

During the MBFP construction phase, development will also occur at the East Portal. The following activities will occur at the East Portal.

- Construction of the East Portal entry areas that will consist of a reinforced concrete retaining wall.
- Installation of enclosed conveyors from the portal face to the coal storage facilities.
- Construction of the coal storage facilities.
- Construction of an enclosed overland conveyor from the coal storage facilities to the Plant.
- Construction of the Mine's office, maintenance shop, and warehouse facilities.

Emission sources associated with the Mine during the development phase are shown in Table 3.1.

**Table 3.1 – Mine Development Particulate Emissions**

Development Year	Coal Conveying and Loading PM <sub>10</sub> (tpy)	Coal to Seminole II PM <sub>10</sub> (tpy)
1	0.16	26.8
2	0.72	104.9
3	0.63	93.0

The above emissions were based on calculations provided in Permit Application AP 2989 for the Carbon Basin Mines. Only particulate emissions associated with the Mine were included. Detailed emission calculation spreadsheets are included in Appendix B.

## **3.2 THE PLANT**

### **3.2.1 Emission Sources**

Emissions associated with this Plant include both point source and fugitive emission sources. The three combustion turbines account for the majority of NO<sub>x</sub>, CO, SO<sub>2</sub>, and PM<sub>10</sub> emissions, while storage tanks and equipment leaks emit the most VOCs and HAPs. Table 3.2 shows significant point and fugitive sources of emission.

Manufacturer specifications for the turbines and certain other equipment are included in Appendix C. With regard to the combustion turbines, a General Electric (GE) specification sheet has been included in Appendix C; this specification does not constitute a vendor guarantee from GE. Equipment-specific guarantees could not be obtained from vendors at this time. Guarantees for some equipment will be obtained at the time purchase contracts are signed.

Due to the long lead-time needed to design this Plant, specific manufacturers and models have not yet been identified for many equipment items, and manufacturer specifications are not yet available.

A list of other major equipment is included in Appendix D, along with a list of source classification codes (SCCs) for point source equipment.



Table 3.2 – Emission Units and Fugitive Sources

Description	Identification	Size	Use
<i>Normally Operating Equipment and Fugitive Sources</i>			
Combustion Turbine 1	CT-1	66 MW	Electrical and steam generation
Combustion Turbine 2	CT-2	66 MW	Electrical and steam generation
Combustion Turbine 3	CT-3	66 MW	Electrical and steam generation
Auxiliary Boiler	AB	66 MMBtu/hr	Steam generation (normal service is standby at 25% load to prevent freeze ups if there is a Plant shutdown)
Catalyst Regenerator	B-1	21.53 MMBtu/hr	Catalyst regeneration (only during catalyst regeneration; average continuous rate is approximately 9 MMBtu/hr)
Reactivation Heater	B-2	12.45 MMBtu/hr	Reactivation heating
HGT Reactor Charge Heater	B-3	2.22 MMBtu/hr	Reactor charge heating
HP Flare (pilot only)	FL-1	0.82 MMBtu/hr	For safety and VOC control
LP Flare (pilot only)	FL-2	0.20 MMBtu/hr	For safety and VOC control
Equipment Leaks	EL	N/A	N/A
Storage Tanks	Tanks	Various	Primarily methanol and gasoline storage
Coal Storage	CS	N/A	Coal feedstock storage
<i>SSM Equipment</i>			
Gasifier Preheater 1*	GP-1	21 MMBtu/hr	Gasifier refractory preheating
Gasifier Preheater 2*	GP-2	21 MMBtu/hr	Gasifier refractory preheating
Gasifier Preheater 3*	GP-3	21 MMBtu/hr	Gasifier refractory preheating
Gasifier Preheater 4*	GP-4	21 MMBtu/hr	Gasifier refractory preheating
Gasifier Preheater 5*	GP-5	21 MMBtu/hr	Gasifier refractory preheating
Black-Start Generator 1	Gen-1	2889 hp	Electrical generation
Black-Start Generator 2	Gen-2	2889 hp	Electrical generation
Black-Start Generator 3	Gen-3	2889 hp	Electrical generation
Firewater Pump Engine	FW-Pump	575 hp	Supplies emergency firewater
CO <sub>2</sub> Vent Stack	CO <sub>2</sub> VS	N/A	For malfunctions

\* These emission units operate less than 8,760 hr/yr under normal conditions.

### 3.2.2 Normal Operations

Plant emissions are broken down into three categories (normal operation, cold startup/initial year emissions, and malfunctions). Annual emissions resulting from normal operations include emissions from equipment that operates continuously (8,760 hours per year) and equipment that operates on a regular basis. For example, the firewater pump engine may operate up to 500 hours in a typical year. Consequently, firewater pump engine emissions are included in the normal operation annual emission summary and are based on 500 hr/yr rather than 8,760 hr/yr. Note that the Auxiliary Boiler normally operates at only 25 percent load, on a hot standby basis.

Table 3.3 shows emissions resulting from normal operations and the maximum number of hours of operation per year. Detailed emission calculations are included in Appendix B.

Table 3.3 – Emissions Resulting from Normal Operations (tpy)

Source ID	Description	Operating Hours (hr)	Potential Emissions (tpy)				
			NO <sub>x</sub>	CO	VOC	SO <sub>x</sub>	PM <sub>10</sub>
CT-1	Power Generation	8,760	75.86	46.19	6.59	10.79	43.80
CT-2	Power Generation	8,760	75.86	46.19	6.59	10.79	43.80
CT-3	Power Generation	8,760	75.86	46.19	6.59	10.79	43.80
AB	Steam Generation	8,760	2.60	2.68	0.29	0.04	0.36
B-1	Catalyst Regeneration	8,000	0.82	2.30	0.15	0.02	0.21
B-2	Reactivation Heater	1,456	0.33	0.94	0.06	0.01	0.08
B-3	HGT Reactor Charge Heater	8,760	0.36	1.00	0.07	0.01	0.09
Tanks	Product Storage	8,760	0.00	0.00	102.62	0.00	0.00
EL	Equipment Leaks	8,760	0.00	0.00	71.32	0.00	0.00
CS	Coal Storage	8,760	0.00	0.00	0.00	0.00	60.18
FW-Pump	Firewater Pump Engine <sup>1</sup>	500	1.51	0.09	0.34	0.00	0.02
FL-1	HP Flare	8,760 <sup>2</sup>	0.49	0.98	2.97	0.00	0.00
FL-2	LP-Flare	8,760 <sup>2</sup>	0.12	0.25	0.74	0.00	0.00
<b>Total Emissions</b>			<b>233.80</b>	<b>146.80</b>	<b>198.33</b>	<b>32.46</b>	<b>192.34</b>

1. The Firewater Pump combusts diesel fuel.

2. Based on continuous natural gas pilot for flares.

### 3.2.3 Cold Start/Initial Year Operations

Annual emissions have also been calculated for the initial year of operations (plant cold start). The complete Plant startup period may last as long as 180 days, and will involve bringing equipment online in a particular order. Emissions during the cold startup period will differ from those during a normal operating year. Certain equipment, such as Black-Start Generators and Gasifier Preheaters, will operate during cold startup. Individual emission units will have much shorter startup time periods; these unit-specific time periods are shown in Appendix B in the cold startup emission summary spreadsheet. Since the Plant will not have produced adequate in-plant fuels and power generation will ramp up slowly, most combustion equipment will initially burn only natural gas fuel, rather than the fuel mixture of fuel gas, LPG, and natural gas. Table 3.4 shows the annual emissions resulting from Cold Startup.

Table 3.4 – Annual Emissions Resulting from Cold Startup (tpy)

Source ID	Description	Operating Hours Fuel Gas Mixture/NG	Potential Emissions (tpy)				
			NO <sub>x</sub>	CO	VOC	SO <sub>2</sub>	PM <sub>10</sub>
CT-1	Power Generation	7760 / 1000	76.68	46.61	6.64	10.89	43.80
CT-2	Power Generation	7760 / 1000	76.68	46.61	6.64	10.89	43.80
CT-3	Power Generation	7760 / 1000	76.68	46.61	6.64	10.89	43.80
Gen-1	Black-Start Generator 1	0 / 250	0.80	1.93	0.72	0.00	0.00
Gen-2	Black-Start Generator 2	0 / 250	0.80	1.93	0.72	0.00	0.00
Gen-3	Black-Start Generator 3	0 / 250	0.80	1.93	0.72	0.00	0.00
AB	Steam Generation	0 / 8,760	3.61	4.51	0.40	0.05	0.52
B-1	Catalyst Regeneration	0 / 8,760	0.82	2.30	0.15	0.02	0.21
B-2	Reactivation Heater	0 / 2216	0.39	0.84	0.05	0.01	0.08
B-3	HGT Reactor Charge Heater	0 / 8,760	0.37	0.98	0.06	0.01	0.09
GP-1	Gasifier Preheater 1	0 / 500	0.26	0.43	0.03	0.00	0.04
GP-2	Gasifier Preheater 2	0 / 500	0.26	0.43	0.03	0.00	0.04
GP-3	Gasifier Preheater 3	0 / 500	0.26	0.43	0.03	0.00	0.04
GP-4	Gasifier Preheater 4	0 / 500	0.26	0.43	0.03	0.00	0.04
GP-5	Gasifier Preheater 5	0 / 500	0.26	0.43	0.03	0.00	0.04
Tanks	Product Storage	8,760	0.00	0.00	102.62	0.00	0.00
BL	Equipment Leaks	8,760	0.00	0.00	71.32	0.00	0.00
CS	Coal Storage	8,760	0.00	0.00	0.00	0.00	60.18
FW-Pump	Firewater Pump Engine	500 <sup>1</sup>	1.51	0.09	0.34	0.00	0.02
CO <sub>2</sub> VS	CO <sub>2</sub> Vent Stack	8,760	0.00	348.16	0.02	0.00	0.00
FL-1	HP Flare	8,760 <sup>2</sup>	10.28	81.86	3.11	187.70	0.00
FL-2	LP Flare	8,760 <sup>3</sup>	0.13	0.45	0.00	36.01	0.00
Total Emissions			250.81	586.97	200.31	256.52	192.68

1. The Firewater Pump combusts diesel fuel.

2. Based on continuous natural gas pilot for flare; cold startup includes 50 hr/yr of vents to HP Flare.

3. Based on continuous natural gas pilot for flare; no vents to LP Flare are expected during cold startup.

### 3.2.4 Malfunctions and Other Events

Malfunctions and other events can cause unusual emissions during short periods of time.

Table 3.5 includes four types of malfunctions. Detailed emission calculations for malfunction events are included in Appendix B.

- CO<sub>2</sub> venting
- Venting to the HP Flare
- Venting to the LP Flare
- Gasifier Preheating

**Table 3.5 – Emissions Resulting from Malfunctions and Other Events**

Source ID	Description	Operating Hours	Potential Emissions (tons)				
			NO <sub>x</sub>	CO	VOC	SO <sub>x</sub>	PM <sub>10</sub>
CO <sub>2</sub> VS	CO <sub>2</sub> Vent Stack	50	0.00	73.30	0.01	0.00	0.00
FL-1	HP Flare	8,760	7.83	64.99	0.12	150.16	0.00
FL-2	LP Flare	8,760	0.01	0.00	0.00	14.40	0.00
GP-1	Gasifier Preheater	500	0.26	0.43	0.03	0.00	0.04

1. The hours shown are estimates of annual operating hours, except for the Gasifier Preheater, which is based on 500 hours per preheating event for one gasifier.

**3.2.5 Emissions of PSD-Regulated Pollutants**

The MTG process requires the syngas to be relatively pure in order to prevent the poisoning of the methanol synthesis catalyst. The clean syngas that is used in the MTG process is the same syngas used as fuel throughout the Plant. This cleaning is achieved by running the raw syngas from the gasifiers through a wet scrubber, which cools the raw gas and removes any particulates that are entrained in the gas stream. The raw (sour) gas then flows through the mercury vapor guard beds (mercury removal) and then through the Low Temperature Gas Cleanup process (SELEXOL<sup>®</sup> technology) where the raw syngas is further cleaned and where NH<sub>3</sub>, H<sub>2</sub>S, and COS are removed from the raw syngas. After the SELEXOL<sup>®</sup> process, the gas flows through a final sulfur guard bed to ensure the highest level of sulfur removal (<0.1 ppmv total sulfur).

Trace amounts of some contaminants may be emitted in very small quantities. During the feasibility study, certain trace contaminants were estimated and are shown below.

Contaminant	Concentration	Potential to Emit
Halogens (Cl <sub>2</sub> and F)	<0.01 ppmv	0.001 tpy
Sulfur as H <sub>2</sub> S	<0.09 ppmv	0.009 tpy

At least 90 percent of the lead in the tail gas will be removed by the activated carbon beds that remove mercury. Based on 3 million tons (8,000 TPD) of coal gasified and lead content within the coal averaging 1.93 ppmw (determined by testing), total lead exiting the gasifiers would be 5.79 tpy. Based on a conservative estimate of 90 percent removal, lead emissions from the facility are estimated to be 0.579 tpy.

**3.2.6 Source-Specific Calculation Methods**

The following sections provide additional detail about calculation methods used to estimate emissions from certain types of sources.

**3.2.6.1 Combustion Source Methods**

Most Plant combustion sources can be fueled with either a fuel gas mixture or with natural gas. The fuel gas mixture includes fuel gas and LPG that are produced within the Plant and supplementary natural gas. Mixing of the fuel gas components occurs prior to the combustion chamber of the source. The fuel gas mixture will vary between seasons and due to catalyst efficiency. Methanol production is high when the catalyst is at its beginning of life (BOL), compared to end of life (EOL). Typical molar fractions of fuel gas mixture components are shown in Table 3.6.

**Table 3.6 — Typical Fuel Gas Mixture Composition<sup>1</sup>**

Fuel Component	Winter BOL	Winter EOL	Summer BOL	Summer EOL
Natural Gas	70.30%	63.01%	58.69%	50.82%
LPG	2.99%	2.75%	7.97%	7.19%
MTG Fuel Gas	4.76%	4.37%	5.94%	5.36%
Davy PSA Purge	16.87%	25.19%	21.05%	30.89%
Davy Fuel Gas 1	2.44%	2.13%	3.05%	2.61%
Davy Fuel Gas 2	2.65%	2.55%	3.30%	3.13%
<b>Total</b>	<b>100.00%</b>	<b>100.00%</b>	<b>100.00%</b>	<b>100.00%</b>

1. Molar percentages are given. Based on three turbines operating.

Since the fuel gas mixture is plant-specific, emission factors are not available for the fuel gas mixture. However, since the fuel has a significant methane component and also includes large quantities of C3 and C4 fuels, use of natural gas emission factors is a reasonable approximation. Consequently, emission calculations for non-diesel combustion sources are based on natural gas emission factors. Even so, the differences in heating values between natural gas and the fuel gas mixture causes emissions to differ.

In some circumstances, combustion of the fuel gas mixture is impractical. This is particularly true during initial startup when the plant has not yet produced sufficient quantities of syngas and LPG. Detailed emission calculation spreadsheets (Appendix B) for the combustion turbines, auxiliary boiler, and heaters clearly indicate the number of hours during which natural gas or the fuel gas mixture is being fired.

**3.2.6.2 Storage Tanks**

Storage tank emissions were calculated using the EPA TANKS Program, version 4.09.d, based on use of internal floating roof tanks. TANKS reports for each type of tank having significant emissions are included in Appendix B.

The RVP of product gasoline stored at the site will vary depending on the time of year. Month-to-month vapor pressure variability was accounted for in the calculations. Tanks containing no volatile organic components and those with insignificant emissions are listed on the Tanks detailed calculation page within Appendix B.

**3.2.6.3 Equipment Leaks**

Equipment leak estimates were calculated using the average emission factor approach described in EPA's "Protocol for Equipment Leak Emission Estimates" (EPA-453/R-95-017). EPA-approved Synthetic Organic Chemical Manufacturing Industry (SOCMI) factors were used for the calculations. Although use of the Refinery emission factors was considered, use of the Refinery factors was deemed inappropriate for the following reasons.

- The Plant process is a chemical synthesis process rather than a refinery process.
- SOCMI factors are recommended for use in all industries, except refineries.
- Even within refineries, SOCMI factors are recommended for chemical processes, such as production of methyl tertiary butyl ether (MTBE).
- The refinery emission factor equation usage guidelines specifically disallow corrections for methane concentrations exceeding 10 wt% and some process streams at the Plant will contain more than 10 wt% methane.

Process streams within the Plant were grouped according to composition and service type (gas, light liquid, heavy liquid) and the number of potential equipment leak components was estimated for each process stream group. All streams were assumed to contain fluids for 8,760 hr/yr. Within Appendix B, detailed equipment leak calculations show controlled and uncontrolled emissions. Controlled emissions were calculated using control effectiveness factors for valves in gas or light liquid service and pump seals in light liquid service. The control effectiveness factors are based on implementation of a monthly Leak Detection and Repair (LDAR) program and assume a leak definition of 10,000 ppm. As discussed in the BACT analysis, the Plant will implement an LDAR program.

**3.2.6.4 Flares**

Flaring emission calculations are based on procedures included in "TCEQ Guidance Document for Flares and Vapor Oxidizers" (RG-109, October 2000). This document provides emission factors for NO<sub>x</sub> and CO and advises use of 98% destruction efficiency for VOCs / HAPs and H<sub>2</sub>S.

The HP and LP Flares will be operated with continuous pilots. Consequently, normal operations include combustion emissions based on the design heat input for each flare and assume natural gas firing. Emissions from normal operation at both flares represent pilot gas combustion only, because no process streams will be routinely directed to either flare.

Emissions from large malfunction events were estimated for the HP and LP Flares, due to the possible significant nature of a malfunction event affecting these flares. Malfunction-related emissions from the HP Flare are based on directing all syngas to the flare, which is the largest stream, by volume, that could potentially be directed to the HP Flare. Malfunction-related events affecting the LP Flare for a potential worst-case (high flow rate, high H<sub>2</sub>S content) vent stream that could be directed to the LP Flare.

## SECTION FOUR

## Best Available Control Technology

The proposed Plant is one of the 28 named source categories in 40 CFR §52.21(b)(1) and is classified as a new major source of regulated emissions under the PSD New Source Review (NSR) program. An analysis of the Best Available Control Technology (BACT) is required for sources with potential emissions greater than the PSD established significance thresholds. The BACT analysis evaluates the technical feasibility and cost-effectiveness of emission control options to determine the applicable control technology and emission limits.

BACT is determined on a case-by-case basis taking into consideration technical practicability and economic reasonableness. For PSD BACT requirements, energy and environmental impacts should also be considered. Control technology alternatives are identified for each new or modified source of pollutants based on knowledge of the applicant's particular industry and previous regulatory decisions for other identical or similar sources.

The proposed Plant will be located in Carbon County, Wyoming. Carbon County is currently designated attainment or unclassifiable for all national ambient air quality standards. Table 4.1 evaluates the applicability of BACT requirements.

Table 4.1 – BACT Applicability

Pollutant	Significance Threshold (tpy)	Estimated Facility Potential to Emit (tpy)	BACT Applicable
CO	100	146.80	Yes
NO <sub>x</sub>	100	233.80	Yes
SO <sub>2</sub>	100	32.46	No <sup>1</sup>
PM <sub>10</sub>	100	192.34	Yes
VOC	100	198.33	Yes

1. Although federal PSD regulations do not require BACT for sources with less than 100 tpy of potential emissions, WDEQ requires BACT reviews for minor sources.

### 4.1 BACT REVIEW PROCESS

In a December 1, 1987 memorandum from the EPA Assistant Administrator for Air and Radiation, the agency provided guidance on the "top-down" methodology for determining BACT. The "top-down" process involves the identification of all potentially applicable emission control technologies according to control effectiveness. Evaluation begins with the top or most stringent emission control alternative. If the most stringent control technology is shown to be technically or economically infeasible, or if environmental impacts are severe enough to preclude its use, then it is eliminated from consideration and the next most stringent control technology is similarly evaluated. This process continues until the BACT option under consideration cannot be eliminated. The top control alternative not eliminated is determined to be BACT. This process involves the following five steps from "New Source Review Workshop Manual," DRAFT October 1990, EPA Office of Air Quality Planning and Standards.

- Step 1: Identify all available control technologies with practical potential for application to the specific emission unit for the regulated pollutant under evaluation;
- Step 2: Eliminate all technically infeasible control technologies;
- Step 3: Rank remaining control technologies by control effectiveness and tabulate a control hierarchy;
- Step 4: Evaluate most effective controls and document results; and
- Step 5: Select BACT, which will be the most effective practical option not rejected based on economic, environmental, and/or energy impacts.

Formal use of these steps is not always necessary. However, the BACT requirements have consistently been interpreted to contain two core components that must be met in any determination. First, the BACT analysis must consider the most stringent available technologies (those with the potential to provide the maximum reductions). Second, a determination to use a technology with a lesser potential control efficiency must be supported by an objective analysis of the associated energy, environmental, and economic impacts. Additionally, the minimum control efficiency evaluated in the BACT analysis must at least achieve emission rates equivalent to applicable New Source Performance Standards (NSPS) or other applicable state or federal rules.

The process of identifying potential control technologies involves researching many resources, including a review of existing and historical technologies that have been proposed or implemented for other projects and a survey of available literature. Evaluating the applicability of each control option entails an assessment of feasibility and cost-effectiveness. This process determines the potential applicability of a control technology by considering its commercial availability (as evidenced by past or expected near-term deployment on the same or similar types of emission units). An available technology is one that is deemed commercially available because it has progressed through the following development steps: concept stage; research and patenting; bench scale/laboratory testing; pilot scale testing; licensing and commercial demonstration; and commercial sales.

The evaluation process also considers the project specific physical and chemical characteristics of the gas stream to be controlled. A control method applicable to one emission unit may not be applicable to a similar unit because of differences in the physical and chemical characteristics of gas streams to be controlled.

The following BACT analysis for the proposed Plant was conducted in a manner consistent with the top-down approach. As part of this analysis, control options for potential reductions were identified by researching the EPA Reasonably Available Control Technology (RACT)/BACT/Lowest Achievable Emission Rate (LAER) Clearinghouse (RBLC) database and by drawing upon engineering, integrated gasification combined cycle (IGCC) process, and industrial gasification permitting experience, and by surveying available literature. IGCC facilities employ several processes similar to the proposed Plant. Potential controls identified were then evaluated as necessary on a technical, economic, environmental, and energy basis.



**4.2 BACT SUMMARY**

Table 4.2 summarizes BACT proposed for this project:

**Table 4.2 - Summary of BACT Applied to the Plant**

Source	Proposed BACT Method
Combustion Turbine/HRSG/Steam Turbine Combined Cycle Trains (3x3x1)	NO <sub>x</sub> SCR with NO <sub>x</sub> control to 6 ppmvd NO <sub>x</sub> (corrected to 15% O <sub>2</sub> ) in the HRSG exhaust when firing fuel gas mixture or natural gas CO: Catalytic Oxidation control to 6 ppmvd CO (corrected to 15% O <sub>2</sub> ) in the HRSG exhaust when firing fuel gas mixture or natural gas VOC: Collateral control from Catalytic Oxidation control to 1.4 ppmvw CO (corrected to 15% O <sub>2</sub> ) in the HRSG exhaust when firing fuel gas mixture or natural gas PM/PM10: Good combustion practices SO <sub>2</sub> : SRU system designed to reduce fuel sulfur concentrations to 0.1 ppmvd and combustion of low sulfur natural gas as supplementary fuel
Auxiliary Boiler and Process Heaters	NO <sub>x</sub> : Low NO <sub>x</sub> burners CO, VOC, PM/PM10: Good combustion practices SO <sub>2</sub> : SRU system designed to reduce fuel sulfur concentrations to 0.1 ppmvd and combustion of low sulfur natural gas as supplementary fuel
Storage Tanks	Gasoline, Methanol, Heavy Gasoline, and Slop Storage tanks will have internal floating roofs; all other tanks will have fixed roofs
Coal Handling	Dust suppression (fogging) used in combination with fully enclosed conveyors and passive engineering design at transfer points
Equipment Fugitives	VOC: Leak Detection and Repair (LDAR) program
Sulfur Recovery Unit (flare and thermal oxidizer)	Re-route tail gas to upstream point in SELEXOL <sup>®</sup> Unit
Carbon Dioxide Vent	Startup, shutdown, upset conditions only (<50 hours/year), optimized process design
Gasifier Preheaters	Low sulfur fuel (natural gas), good combustion practices, restricted operation (initial startup and new refractory only, < 500 hours/year per gasifier)
Black-Start Generators	Low sulfur fuel (natural gas), good combustion practices, restricted operation (initial startup only, <250 hours/year)
Firewater Pump	Restricted operation (<500 hours/year), ultra-low-sulfur diesel fuel (15 ppm sulfur), good combustion practices

### 4.3 COMBUSTION TURBINE CONTROL TECHNOLOGY REVIEW

The following is the BACT analysis for the proposed combustion turbines. Each of the three proposed combustion turbines will be a GE 7EA model turbine with a nominal capacity of 66 MW at average ambient conditions. Each combustion turbine will have a heat recovery steam generator (HRSG), and all three will utilize one steam turbine generator, in a 3 x 3 x 1, combined cycle configuration. The primary fuel will be a fuel gas mixture comprised of imported natural gas plus process generated fuels including: LPG from the MTG process, and fuel gas from both the Davy and MTG synthesis processes. By volume, the combustible portion of this natural gas based fuel mixture will consist primarily of methane (61.4%), hydrogen (15.3%), and butane (5.1%). Each combustion turbine will also be capable of firing natural gas, for startup, fuel enrichment, and backup purposes. Finally, under certain market conditions, each combustion turbine may also be fired with a syngas-based fuel mixture. By volume, the combustible portion of this syngas-based fuel mixture will consist primarily of hydrogen (46.1%) and CO (44.5%) with a small amount of hydrocarbons.

#### 4.3.1 Nitrogen Oxides BACT Analysis for the Combustion Turbines

NO<sub>x</sub> is formed during combustion primarily by the reaction of combustion air nitrogen and oxygen within the high temperature combustion zone (thermal NO<sub>x</sub>), or by the oxidation of nitrogen in the fuel (fuel NO<sub>x</sub>). Because the tail gas contains negligible amounts of fuel-bound nitrogen, essentially all combustion turbine NO<sub>x</sub> emissions originate as thermal NO<sub>x</sub>.

The rate of thermal NO<sub>x</sub> formation in the combustion turbines is primarily a function of the fuel residence time, availability of oxygen, and peak flame temperature. Several NO<sub>x</sub> control technologies are available to reduce the impacts of these variables during the combustion process, including diluent injection and dry low NO<sub>x</sub> burner technology. Post-combustion control technologies have also been used in some processes to remove NO<sub>x</sub> from the exhaust gas stream.

#### *Identify Control Technologies*

The following NO<sub>x</sub> control technologies were evaluated for the proposed combustion turbines:

##### Combustion Process Controls

- Diluent Injection
- Dry Low NO<sub>x</sub> Burners
- Low NO<sub>x</sub> Burners
- Flue Gas Recirculation

##### Post-Combustion Controls

- EMx<sup>TM</sup>
- Selective Non-Catalytic Reduction (SNCR)
- Selective Catalytic Reduction (SCR)

**Evaluate Technical Feasibility****Diluent Injection**

Higher combustion temperatures may increase thermodynamic efficiency, but may also increase the formation of thermal  $\text{NO}_x$ . A diluent, such as water, steam, or nitrogen can be added to the fuel gas mixture to effectively reduce the combustion temperature and formation of thermal  $\text{NO}_x$ . The fuel gas mixture combusted in the combustion turbines contains small amounts of  $\text{N}_2$  and  $\text{CO}_2$ , both of which act as a diluent. However, additional dilution would be necessary to achieve meaningful  $\text{NO}_x$  reductions. Diluent injection is a technically feasible control technology for the proposed combustion turbines while firing the fuel gas mixture.  $\text{N}_2$  produced in the ASU could be introduced to the turbine burners in this instance to reduce combustion temperatures. In addition, when the turbines are firing natural gas only, nitrogen from the ASU could be introduced as a diluent also. There may be brief periods of time when the turbines are first started (on natural gas) when no diluent from the ASU is available. This is expected to be a very short time period as the ASU is one of the first units started during the startup sequence.

**Dry Low  $\text{NO}_x$  Burners**

Dry Low  $\text{NO}_x$  (DLN) burner technology has successfully been demonstrated to reduce thermal  $\text{NO}_x$  formation from combustion turbines firing natural gas. This technology utilizes a burner design that controls the stoichiometry and temperature of combustion by regulating the distribution and pre-mixing of fuel and air, which minimizes localized fuel-rich pockets that produce elevated combustion temperatures and higher  $\text{NO}_x$  emissions.

Available DLN burner technologies for combustion turbines are designed for natural gas (methane-based) fuels, but are not applicable to combustion turbines utilizing a fuel gas mixture, which has a different heating value, gas composition, and flammability characteristics. Research is ongoing to develop DLN technologies for tail gas (or fuel gas mixtures) and syngas-fueled combustion turbines, but no designs are currently available. In particular, the turbine vendor has stated that DLN is not feasible for fuels that contain less than 85% by volume methane or that contain substantial amounts of hydrogen. The fuel gas mixture that will be utilized in the turbines contains too little methane (61.4%) and too much hydrogen (15.3%). Therefore, DLN burner technology is not technically feasible for the Plant turbines due to potential explosion hazards in the combustion section associated with the high content of hydrogen in the fuel gas mixture.

**Low  $\text{NO}_x$  Burners**

Low  $\text{NO}_x$  burners are widely used to reduce  $\text{NO}_x$  emissions. A conventional low  $\text{NO}_x$  burner is designed to control fuel and air mixing at each burner in order to create larger and more branched flames. This reduces peak flame temperature and results in less  $\text{NO}_x$  formation. In addition, the improved flame structure reduces the amount of oxygen available in the hottest part of the flame and improves burner efficiency. In contrast to DLN burners, low  $\text{NO}_x$  burners can be used with a variety of gaseous fuels. Low  $\text{NO}_x$  burner technology is technically feasible for Plant turbines.

**Flue Gas Recirculation**

Flue gas recirculation is being researched by combustion turbine manufacturers, but is not currently an available control technology. While the technology may be a future option to

reduce NO<sub>x</sub> emissions, significant development work is required to complete maturation and integration of the concept into a power plant system, including validating all emissions characteristics and overall plant performance and operability. Additionally, current research efforts have focused on pre-mixed natural gas combustion, and results would need to be expanded to assess fuel gas mixture applications. Thus, flue gas recirculation is not technically feasible for the proposed combustion turbines.

**EMx™**

EMx™ (formerly known as SCONOX) is a control technology that utilizes a single catalyst to minimize CO, VOC, and NO<sub>x</sub> emissions. All installations of the technology have been on small natural gas facilities. EMx™ has not been applied to large-scale fuel gas mixture/syngas combustion turbines, which creates concerns regarding the timing, feasibility of scaling up to a larger unit and use of different fuel, cost-effectiveness of necessary design improvements, and potential catalyst fouling. Therefore, EMx™ is not technically feasible.

**Selective Non-Catalytic Reduction (SNCR)**

SNCR is a post-combustion NO<sub>x</sub> control technology in which a reagent (ammonia or urea) is injected in the exhaust gas to react with NO<sub>x</sub> to form nitrogen and water without the use of a catalyst. The success of this process in reducing NO<sub>x</sub> emissions is highly dependent on the ability to uniformly mix the reagent into the flue gas, which must occur in a very narrow high temperature range. The consequences of operating outside the optimum temperature range are severe. Above the upper end of the temperature range, the reagent will be converted to NO<sub>x</sub>. Below the lower end of the temperature range, the reagent will not react with the NO<sub>x</sub>, resulting in excess ammonia emissions. SNCR technology is occasionally used in conventional coal-fired heaters or boilers, but it has never been applied to natural gas combined cycle or syngas/fuel gas mixture units because no locations exist in the heat recovery steam generator with the optimal temperature and residence time that are necessary to accommodate the technology. Therefore, SNCR is not technically feasible.

**Selective Catalytic Reduction (SCR)**

SCR technology has never been attempted at an IGCC plant using coal-derived syngas. BACT analyses for previously permitted IGCC plants have determined SCR is not technically feasible due to concerns regarding a back pressure energy penalty, catalyst performance, and potential operational impacts to downstream equipment from the sulfur content in the fuel. Several analyses noted the unavailability of meaningful performance guarantees from SCR suppliers. In other cases, the application of SCR to the IGCC process was not deemed cost effective due to increased operation and maintenance costs and the costs associated with reducing syngas sulfur to levels that are assumed to be adequate to minimize operational impacts.

MBFP's initial evaluation of the application of SCR to the Plant indicates that due to the extremely high sulfur removal necessary for the MTG process, catalyst fouling and other operational concerns due to sulfur in the fuel would be alleviated. The gas fed to the Methanol Synthesis Unit requires less than 30 ppb sulfur. All fuel gas used throughout the plant is first desulfurized in the acid gas removal (AGR) unit and sulfur beds, and therefore contains less than 30 ppb sulfur (expressed as H<sub>2</sub>S). In summary, under the proposed fuel gas mixture-firing scenario, SCR is believed to be technically feasible.

During most startup operations, the combustion turbines will be fired with fuel gas mixture. However, for the initial startup and some cold startup scenarios, natural gas will be used to fire the combustion turbines. SCR is not technically feasible during the initial startup operations due to the low temperature where the SCR would be applied. Whether firing natural gas or the fuel gas mixture, the SCR will be utilized as soon as the exhaust temperature reaches the operational range of the SCR.

### **Rank Control Technologies**

Low NO<sub>x</sub> burners, SCR, and diluent injection are the NO<sub>x</sub> control technologies that are technically feasible for the proposed combustion turbines during normal operations when firing either the fuel gas mixture or natural gas.

### **Evaluate Control Options**

The use of low NO<sub>x</sub> burners and SCR was identified as the only technically feasible NO<sub>x</sub> control technology for the proposed combustion turbines during normal operations. The low NO<sub>x</sub> burners are expected to achieve 25 ppm NO<sub>x</sub> in turbine exhaust. The use of SCR will further reduce NO<sub>x</sub> emissions to 6 ppmvd (at 15% O<sub>2</sub>) when firing syngas (fuel gas mixture). The nominal gross output for the 3 x 3 x 1 generator/HRSG/ steam turbine configuration is 400 MW. Therefore, the equivalent potential NO<sub>x</sub> emission rate is approximately 0.135 lb/MWh, significantly lower than the applicable NSPS Subpart Da or KKKK limit of 1.0 and 3.6 lb/MWh respectively.

The use of low NO<sub>x</sub> burners and diluent injection combined with SCR was identified as the only technically feasible combination of NO<sub>x</sub> control technologies for the proposed combustion turbines during natural gas firing operations. These combined technologies will reduce NO<sub>x</sub> emissions to 6 ppmvd (at 15% O<sub>2</sub>).

With one exception, the proposed NO<sub>x</sub> BACT limit of 6 ppmvd (corrected to 15% O<sub>2</sub>) is well below emission limits found on the RACT/BACT/LAER Clearinghouse for similar turbines firing either syngas or tail gas. Appendix E provides a summary of emission control determinations for these turbines. For completeness, all RACT/BACT/LAER emission control determinations for process type 15.250 (explained in Appendix E) are included. The most stringent NO<sub>x</sub> BACT limit for a combined cycle combustion turbine firing syngas or tail gas is 1.9 ppmvd (corrected to 15% O<sub>2</sub> and based on an annual average) for the Bayport Energy Facility. However, this facility utilizes DLN technology to achieve this level of NO<sub>x</sub> emissions. For reasons described above, DLN is not technically feasible for the Plant. The next most stringent NO<sub>x</sub> BACT limit is 8 ppmvd (corrected to 15% O<sub>2</sub> and based on a 30-day rolling average) for the Exxon Mobil Shute Creek facility. The Exxon-Mobil facility uses a proprietary mix of gas that includes syngas as one component. All other fueled combustion turbines shown in Appendix E have NO<sub>x</sub> emission limits of 15 ppmvd (corrected to 15% O<sub>2</sub>) or more.

As the first implementer of SCR technology on this type of turbine/fuel combination, the 6 ppmvd NO<sub>x</sub> emission limit reflects a level of control within the accepted range of SCR control efficiencies (70-90 percent control efficiency). Specifically, a reduction from 25 ppmvd to 6 ppmvd is estimated, representing a long-term 76 percent reduction in NO<sub>x</sub> from 80 percent SCR performance when the system is new and clean. Technical issues such as pressure loss in

the combustion turbine and ammonia slip argue against expecting the highest level of control efficiency for this innovative installation of SCR.

Moreover, the additional cost of reducing NO<sub>x</sub> emissions to below 6 ppm has been estimated, although MBFP believes that achieving NO<sub>x</sub> emissions less than 6 ppmvd (corrected to 15% O<sub>2</sub>) is a technical feasibility issue rather than a cost issue. Variability in plant-generated fuel could potentially increase NO<sub>x</sub> emissions and prevent burner optimization. Consequently, exhaust from the turbines may be somewhat higher than expected. With a 6-ppm NO<sub>x</sub> limit, the facility will have some ability to compensate for high NO<sub>x</sub> concentrations entering the SCR system by increasing NO<sub>x</sub> removal efficiency beyond the 76 percent that would be achieved assuming 25 ppm NO<sub>x</sub> concentration in the turbine exhaust. Based on equipment and operating costs provided by SNC Lavalin, the incremental cost of reducing NO<sub>x</sub> emissions from 6 ppm to 4 ppm, is estimated to be \$2,272/ton removed. This cost estimate is included as Appendix F.

### **Select NO<sub>x</sub> Control Technology**

The use of SCR with diluent injection is proposed as BACT for the proposed combustion turbines during normal operations to reduce NO<sub>x</sub> emissions to 6 ppm when firing fuel gas mixture. The use of SCR with diluent injection is also proposed for natural gas combustion during start up operations. The proposed BACT NO<sub>x</sub> limits are presented below for each combustion turbine.

Proposed NO<sub>x</sub> BACT Limit when burning fuel gas mixture: 6 ppmvd (corrected to 15% O<sub>2</sub>)

Proposed NO<sub>x</sub> BACT Limit when burning natural gas: 6 ppmvd (corrected to 15% O<sub>2</sub>)

The NO<sub>x</sub> BACT limits expressed for each combustion turbine are for normal operations. During startup and shutdown operations, NO<sub>x</sub> emissions may be greater for certain periods due to unstable combustion associated with lower combustion turbine efficiencies and transitional periods between fuels. Potential emissions for startup and shutdown operations are provided in the Emissions Inventory and are evaluated as part of the air dispersion modeling analysis. See Section 4.3.5 for more information regarding startup operations.

### **4.3.2 Sulfur Dioxide BACT Analysis for the Combustion Turbines**

The combustion turbines oxidize sulfur compounds in fuel primarily into sulfur dioxide (SO<sub>2</sub>). Emissions can be controlled by limiting the fuel sulfur content or by removing SO<sub>2</sub> from the exhaust gas.

### **Identify Control Technologies**

The following SO<sub>2</sub> control technologies were evaluated for the proposed Plant combustion turbines.

**Pre-Combustion Process Controls**

Chemical Absorption Acid Gas Removal  
Physical Absorption Acid Gas Removal  
Low Sulfur Fuel

**Post-Combustion Controls**

Flue Gas Desulfurization

***Evaluation Technical Feasibility*****Chemical and Physical Acid Gas Removal Systems**

During the gasification process, sulfur in the feedstock converts primarily into H<sub>2</sub>S, and will also convert into minor quantities of other sulfur species, such as COS. Commercially available AGR systems are capable of removing greater than 99% of the sulfur compounds from syngas/tail gas. AGR systems are commonly used for gas sweetening processes of refinery fuel gas or tail gas treatment systems, and are typically coupled with processes that produce useful sulfur byproducts.

AGR systems can employ either chemical or physical absorption methods. Chemical absorption methods are amine-based systems that utilize solvents, such as methyldiethanolamine (MDEA), to bond with the H<sub>2</sub>S in the tail gas. A stripper column is then used to regenerate the solvent and produce an acid gas stream containing H<sub>2</sub>S that can be processed into useful sulfur by-products. An MDEA AGR system has been determined as BACT for all operating and permitted IGCC facilities. The two operating IGCC facilities in the United States both use amine (MDEA) systems to reduce the syngas total sulfur concentration to 100 to 400 ppm. The process involves taking the gas out of the AGR removal process and passing it through a methanol synthesis process, and the gases coming out of the methanol and MTG processes (fuel gas mixture) are used as fuel in the combustion turbines. In order for the methanol process to function properly the sulfur content in the gas must be less than 0.1 ppm sulfur. Therefore, chemical absorption methods, even with the use of sulfur beds, are not technically feasible for the Plant's process.

Other types of AGR systems utilize physical absorption methods that employ a physical solvent to remove sulfur from gas streams, such as mixtures of dimethyl ethers of polyethylene glycol (SELEXOL<sup>®</sup>) or methanol (Rectisol). These systems operate by absorbing H<sub>2</sub>S under pressure into the solvent. Dissolved acid gases are removed resulting in a regenerated solvent for reuse and the production of an acid gas stream containing H<sub>2</sub>S that can be processed into useful sulfur by-products. Physical absorption methods have historically been used to purify gas streams in the chemical processing and natural gas industries, and can achieve sulfur removal to the level required by methanol process of less than 0.1 ppm sulfur. This sulfur concentration can feasibly be reduced to the sulfur content required by the methanol unit through the use of sulfur removal beds. Physical acid gas removal systems are a technically feasible control technology.

**Low Sulfur Fuel**

Providing low sulfur fuel to the turbines is another pre-combustion emission control method. The AGR system described above removes sulfur from the fuel gas streams in order to provide

low sulfur fuel gas to the combustion turbines. However, additional fuel is needed for the turbines. Natural gas is a low sulfur fuel that can be used to supplement fuel gases produced at the Plant. The combustion turbines' burners are compatible with Plant-produced fuel gases, natural gas, and a combination of both types of fuels. When firing natural gas exclusively, SO<sub>2</sub> emissions are conservatively estimated to be 0.0034 lb per MMBtu. Use of natural gas as the supplementary fuel is a technically feasible option.

#### **Flue Gas Desulfurization**

Flue gas desulfurization (FGD) is a post-combustion SO<sub>2</sub> control technology that reacts an alkaline compound with SO<sub>2</sub> in the exhaust gas. FGD systems are most commonly used by conventional pulverized coal units and can typically achieve greater than 95% removal efficiency on new facilities. The FGD process results in a solid by-product that requires the installation of a significant number of ancillary support systems to accommodate treatment, handling, and disposal. FGD is more readily applied to high SO<sub>2</sub> concentration gas streams, such as those present with direct combustion coal units. No examples were identified where an FGD system has been applied to a tail gas/syngas fired combustion turbine facility or similar process, such as a natural gas fired unit. Therefore, FGD is not technically feasible for the proposed combustion turbines. Even if feasible to the tail gas fired processes, FGD could not achieve the high removal efficiencies associated with AGR systems and would not provide appreciable SO<sub>2</sub> removal.

#### **Rank Control Technologies**

The use of physical acid gas removal for process fuels and use of low sulfur natural gas fuel were identified as the only technically feasible SO<sub>2</sub> and acid gas emissions control technologies applicable to the proposed combustion turbines.

#### **Evaluate Control Options**

With regard to Plant-produced fuels, physical acid gas removal is the only feasible control technology identified, and is proposed as BACT for this project. Sulfur removal will occur prior to the methanol catalyst and will reduce the sulfur content to less than 0.1 ppmvd.

The AGR design reduces syngas sulfur concentrations by greater than 99%, and produces a secondary gas stream that can be processed into potentially useful sulfur byproducts. The solvent used by the AGR system will be regenerated and reused. Any related water streams will be treated, as the facility will be a zero water discharge facility. Overall, no collateral environmental issues have been identified that would preclude the AGR design option from consideration as BACT for the proposed project.

With regard to supplementary fuels, use of natural gas is the only feasible control method.

#### **Select SO<sub>2</sub> Control Technology**

A physical absorption AGR system designed to reduce tail gas sulfur concentrations to 0.1 ppm (expressed as H<sub>2</sub>S) is proposed as BACT for SO<sub>2</sub> emissions from the proposed combustion turbines. The proposed AGR system will reduce fuel gas mixture sulfur content by greater than 99%. The gas fed to the Methanol Synthesis Unit requires less than 0.1 ppm, and therefore sulfur guard beds will be used to reach less than 0.1 ppm of sulfur. All fuel gas used throughout



the plant is first desulfurized in the AGR units and sulfur beds, and therefore contains less than 0.1 ppm sulfur (expressed as H<sub>2</sub>S).

Although the fuel gas has very low sulfur content, the turbines burn a large proportion of natural gas as part of the fuel gas mixture (see Table 3.6 for fuel gas mixture components). Consequently, the proposed BACT limits associated with combustion of the fuel gas mixture, as well as natural gas, are based on AP-42 factors of 0.0034 lb/MMBtu.

Proposed SO<sub>2</sub> BACT Limit when burning fuel gas mixture: 0.0034 lb/MMBtu

Proposed SO<sub>2</sub> BACT Limit when burning natural gas: 0.0034 lb/MMBtu

### ***Carbon Monoxide BACT Analysis for the Combustion Turbines***

CO emissions are a result of incomplete combustion. Providing adequate fuel residence time and higher temperatures in the combustion zone to ensure complete combustion can reduce CO emissions. However, these same control factors can increase NO<sub>x</sub> emissions. Conversely, reduce NO<sub>x</sub> emission rates achieved through flame temperature control (by diluent injection) can increase CO emissions. The design strategy is to optimize the flame temperature to reduce potential NO<sub>x</sub> emissions, while minimizing the impact to potential CO emissions. The combustion turbines for the proposed project will be a GE 7EA model, which is designed to optimally consume fuel gas mixture. Post-combustion control technologies have also been used to reduce CO emissions in some processes.

### ***Identify Control Technologies***

The following CO control technologies were evaluated for the proposed combustion turbines.

#### **Combustion Process Controls**

Good Combustion Practices

#### **Post-Combustion Controls**

EMx™

Oxidation Catalyst

### ***Evaluate Technical Feasibility***

#### **Good Combustion Practices**

Good combustion practices include the use of operational and design elements that optimize the amount and distribution of excess air in the combustion zone to ensure complete combustion. This technology has been determined to be BACT for CO emissions for combustion turbines, which use syngas/fuel gas mixture fired combustion turbines.

#### **EMx™**

The EMx™ system was evaluated in the NO<sub>x</sub> BACT analysis, and determined to not be technically feasible.

**Oxidation Catalysts**

Catalytic oxidation is a post-combustion control technology that utilizes a catalyst to oxidize CO into CO<sub>2</sub>. Due to the significant portion of natural gas in the fuel gas mixture, oxidation catalyst is technically feasible for the Plant's turbines.

**Rank Control Technologies**

Good combustion practice and catalytic oxidation are the only technically feasible CO control technology identified.

**Evaluate Control Options**

Good combustion practice and catalytic oxidation are the only feasible control technology identified, and has been determined to be BACT for CO emissions for combustion turbines.

**Select CO Control Technology**

Good combustion practice and catalytic oxidation are proposed as BACT for CO emissions from the proposed combustion turbines. The use of good combustion practices is expected to achieve CO emissions of 6 ppmvd (at 15% O<sub>2</sub>).

Proposed CO BACT Limit when burning fuel gas mixture: 6 ppmvd (corrected to 15% O<sub>2</sub>)

Proposed CO BACT Limit when burning natural gas: 6 ppmvd (corrected to 15% O<sub>2</sub>)

The CO BACT limits expressed for each combustion turbine are for normal operations. During startup and shutdown operations, CO emissions may be greater for certain periods due to unstable combustion associated with lower combustion turbine efficiencies and transitional periods between fuels. Potential emissions for startup and shutdown operations are provided in the Emissions Inventory and are evaluated as part of the air dispersion modeling analysis. See Section 4.3.5 for more information regarding startup operations.

**4.3.3 Volatile Organic Compound BACT Analysis for the Combustion Turbines**

VOC emissions are a product of incomplete combustion. Providing adequate fuel residence times and higher temperatures in the combustion zone to ensure complete combustion can reduce VOC emissions. The design strategy is to optimize the flame temperature to reduce potential NO<sub>x</sub> emissions, while minimizing the impact to potential VOC emissions. The combustion turbines for the proposed project will be a GE 7EA model, designed to optimally consume fuel gas mixture. Post-combustion control technologies have also been used to reduce VOC emissions in some processes.

***Identify Control Technologies***

The following VOC technologies were evaluated for the proposed combustion turbines.

**Combustion Process Controls**

Good Combustion Practices

**Post-Combustion Controls**

EMx™

Catalytic Oxidation

***Evaluate Technical Feasibility*****Good Combustion Practices**

Good combustion practices include the use of operational and design elements that optimize the amount and distribution of excess air in the combustion zone to ensure complete combustion. This technology has been determined to be BACT for VOC emissions from syngas fired combustion turbines in IGCC permits nationwide.

**EMx™**

The EMx™ system was evaluated in the NO<sub>x</sub> BACT analysis, and determined to not be technically feasible.

**Catalytic Oxidation**

Catalytic oxidation, primarily a CO control device with limited VOC control, was evaluated in the CO BACT analysis, and determined to be technically feasible.

***Rank Control Technologies***

Good combustion practice and catalytic oxidation are the only technically feasible VOC control technology identified.

***Evaluate Control Options***

Good combustion practice and catalytic oxidation are the only feasible control technology identified, and has been selected as BACT for syngas fired combustion turbines.

***Select VOC Control Technology***

Good combustion practice and catalytic oxidation are proposed as BACT for VOC emissions from the proposed combustion turbines. The BACT emission limit is proposed below.

Proposed VOC BACT Limit when burning fuel gas mixture: 1.4 ppmvw (corrected to 15% O<sub>2</sub>)

Proposed VOC BACT Limit when burning natural gas: 1.4 ppmvw (corrected to 15% O<sub>2</sub>)

The VOC BACT limit expressed for each combustion turbine is for normal operations. During startup and shutdown operations, VOC emissions may be greater for certain periods due to unstable combustion associated with lower combustion turbine efficiencies and transitional periods between fuels. Potential emissions for startup and shutdown operations are provided in the Emissions Inventory and are evaluated as part of the air dispersion modeling analysis. See Section 4.3.5 for more information regarding startup operations.

#### **4.3.4 Particulate Emissions BACT Analysis for the Combustion Turbines**

Fuel quality and combustion efficiency are key drivers impacting the quantity and disposition of potential particulate emissions. In some processes, post-combustion control technologies can also be used to reduce particulates.

##### ***Identify Particulate Emission Control Technologies***

The following particulate emission control technologies were evaluated for the proposed combustion turbines.

##### **Combustion Process Controls**

Clean Fuels with Low Potential Particulate Emissions

Good Combustion Practices

##### **Post-Combustion Controls**

Electrostatic Precipitation

Baghouse

##### ***Evaluate Technical Feasibility***

##### **Clean Fuels with Low Potential Particulate Emissions**

Higher ash content fuels have the potential to produce greater particulate emissions. In addition, fuels containing sulfur have the potential to produce sulfur compounds that may form condensable particulate emissions. Combustion turbine operations require fuels that contain negligible amounts of fuel bound particulate in order to minimize performance impacts. The Plant's process inherently produces a fuel gas mixture containing minimal amounts of particulate. The control of fuel gas mixture sulfur compounds as discussed in the SO<sub>2</sub> BACT analysis will reduce potential condensable particulates. Therefore, the use of clean fuels is a technically feasible control technology.

##### **Good Combustion Practices**

The use of good combustion practices is a technically feasible control technology that minimizes particulate emissions resulting from incomplete combustion, and was proposed as BACT for CO and VOC emissions.

##### **Electrostatic Precipitation**

Electrostatic precipitation (ESP) is a post-combustion particulate control technology most commonly applied to large volume gas streams containing high particulate concentrations, such

as with direct combustion coal units. An ESP has not been applied to syngas/fuel gas mixture combustion turbine operations due to the low particulate concentrations of the associated exhaust gas streams. The use of ESP is not technically feasible based on the particulate matter present in the exhaust gas at the Plant. The particulate matter content will be less than 0.003 grains of PM/dscf.

An ESP can consistently provide PM emission reductions down to 0.002 to 0.015 grains of PM/dscf (from "Controlling Stack Emissions in the Wood Products Industry," Gerry Graham). Therefore, an ESP would not provide additional control. Operation of an ESP is not considered technically feasible for the proposed combustion turbines.

### **Baghouse**

A baghouse is a post-combustion control technology that uses a fine mesh filter to remove particulate emissions from gas streams, and is most commonly applied to industries producing large volume gas streams with high particulate concentrations. A baghouse has not been applied to syngas/fuel gas mixture combustion turbine operations due to the reduced volume and minimal particulate concentration of the associated exhaust gas streams. Use of a baghouse is not technically feasible based on the particulate matter present in the exhaust gas at the Plant. The particulate matter content is less than 0.003 grains of PM/dscf. A baghouse can consistently provide PM emission reductions down to 0.02 grains of PM/dscf. More stringent control can be achieved, but not greater than 0.003 grains of PM/dscf (per The Tenant Company, Griffin Filters, Farr Air Pollution Control). Therefore, a baghouse would not provide additional control and is not considered technically feasible for the proposed combustion turbines.

### **Rank Control Technologies**

The use of clean fuels with low potential particulate emissions and good combustion practices were identified as the only technically feasible particulate emissions control technologies applicable to the proposed combustion turbines.

### **Evaluate Control Technologies**

The use of clean fuels with low potential particulate emissions and good combustion practices were identified as the only technically feasible particulate emissions control technologies applicable to the proposed combustion turbines. These technologies have been determined to be BACT for syngas fired combustion turbines.

### **Select Particulate Emissions Control Technology**

The use of clean fuels with low potential particulate emissions and good combustion practices are proposed as BACT for particulate emissions from the proposed combustion turbines. The following emission limit resulting from the implementation of these technologies is proposed for each combustion turbine.

Proposed Particulate Emissions (PM<sub>10</sub> – filterable) BACT limit when burning fuel gas mixture: 0.013 lb/MMBtu. Based on the Lower Heating value (LHV).

Proposed Particulate Emissions (PM<sub>10</sub> – filterable) BACT limit when burning natural gas: 0.013 lb/MMBtu. Based on the LHV.

The potential particulate combustion turbine emission rates during startup and shutdown operations are less than or equal to the aforementioned BACT limits for normal operations while firing fuel gas mixture. Potential emissions for startup and shutdown operations are provided in the Emissions Inventory and are evaluated as part of the air dispersion modeling analysis. See Section 4.3.5 for more information regarding startup operations.

#### **4.3.5 Startup Emissions BACT Analysis for the Combustion Turbines**

Turbine startup emissions are quantified separately from normal operating emissions. The SCR system used on the turbine/HRSG units does not initially reduce NO<sub>x</sub> emissions since the system must heat up to achieve the operating temperature conducive for proper pollution control operation. When the temperature range is achieved during fuel gas mixture and natural gas startup operations, the SCR system will be engaged and the catalyst will begin to minimize NO<sub>x</sub> emissions.

To satisfy BACT during the startup mode of the turbines, the duration of the startups will be minimized to the best extent possible for each turbine unit.

### **4.4 FIRED HEATER AND BOILER CONTROL TECHNOLOGY REVIEW**

The BACT analysis for the proposed fired heaters and auxiliary boiler applies to three heaters with firing capacity of 21.5 MMBtu/hr to 2.2 MMBtu/hr and a 66 MMBtu/hr boiler. The fuel gas mixture, comprised primarily of methane and hydrogen, will fuel the fired heaters and auxiliary boiler during normal operations. Backup fuel for the heaters and boiler will be natural gas for startup and upset conditions, and is discussed in Section 4.4.5.

#### **4.4.1 NO<sub>x</sub> BACT Analysis for the Fired Heaters and Boiler**

NO<sub>x</sub> is formed during combustion primarily by the reaction of combustion air nitrogen and oxygen in the high temperature combustion zone (thermal NO<sub>x</sub>), or by the oxidation of nitrogen in the fuel (fuel NO<sub>x</sub>). The rate of NO<sub>x</sub> formation is a function of fuel residence time, oxygen availability, and temperature in the combustion zone. Primary fired heater and auxiliary boiler NO<sub>x</sub> control technologies focus on combustion process controls.

##### ***Identify All Control Technologies***

The following potential NO<sub>x</sub> control technologies were evaluated for the proposed auxiliary boiler and fired heaters.

##### **Combustion Process NO<sub>x</sub> Controls**

Low NO<sub>x</sub> Burners

Low NO<sub>x</sub> Burners with Flue Gas Recirculation

##### **Post-Combustion NO<sub>x</sub> Controls**

Selective Catalytic Reduction (SCR)

Selective Non-Catalytic Reduction (SNCR)

Non-Selective Catalytic Reduction (NSCR)

EMx<sup>TM</sup>

*Evaluate Technical Feasibility***Low NO<sub>x</sub> Burners**

Low NO<sub>x</sub> burners reduce the formation of thermal NO<sub>x</sub> by incorporating a burner design that controls the stoichiometry and temperature of combustion by regulating the distribution and mixing of fuel and air. As a result, fuel-rich pockets in the combustion zone that produce elevated temperatures and higher potential NO<sub>x</sub> emissions are minimized. Historically, low NO<sub>x</sub> burners have been selected as BACT for syngas/tail gas-fired heaters and boilers. Therefore, low NO<sub>x</sub> burner technology is technically feasible for the proposed auxiliary boiler and fired heaters.

**Low NO<sub>x</sub> Burners with Flue Gas Recirculation**

Flue gas recirculation (FGR) is used to reduce NO<sub>x</sub> emissions in some processes by recirculating a portion of the flue gas into the main combustion chamber. This process reduces the peak combustion temperature and oxygen in the combustion air/flue gas mixture, which reduces the formation of thermal NO<sub>x</sub>. FGR has the potential to reduce combustion efficiency and cause greater carbon monoxide emissions. A RBLC search was performed over the previous 10-year period for other gaseous fuels and gaseous fuel mixtures in boilers and process heaters less than 100 MMBtu/hr (Process Type 13.390). The search encompassed 24 facilities and 110 processes. Application of FGR was not identified for process heaters less than 100 MMBtu/hr in this search. All the process heaters and the auxiliary boiler at the facility will be less than 100 MMBtu/hr and will emit relatively small quantities of NO<sub>x</sub>. Therefore, FGR has not been previously demonstrated for the intended operation of the fired heaters.

**Selective Catalytic Reduction (SCR)**

SCR is a post-combustion technology that reduces NO<sub>x</sub> emissions by reacting NO<sub>x</sub> with ammonia in the presence of a catalyst. SCR technology has been most commonly applied to pulverized coal generating units and to natural gas fired combustions turbines. A RBLC search was performed over the previous 10-year period for other gaseous fuels and gaseous fuel mixtures in boilers and process heaters less than 100 MMBtu/hr (Process Type 13.390). The search encompassed 24 facilities and 110 processes. Application of SCR was identified at two out of the 24 facilities. Therefore, SCR is technically feasible for the intended operation of the fired heaters. However, at one of the facilities that employed SCR, the RBLC stated that the project was "...to meet the new NO<sub>x</sub> requirements dictated by the SIP." The other facility that employed SCR is located in an area regulated by the same SIP, and fired a fuel comprised primarily of hydrocarbons. Both of the facilities are located in an ozone nonattainment area and SCR was implemented to comply with the state NO<sub>x</sub> rules (SIP). The Plant is not located in a nonattainment area and is therefore not subject to the same stringent NO<sub>x</sub> rules as these two facilities with SCR. Additionally, based on the difference in fuels, the uncontrolled NO<sub>x</sub> emissions would be higher from the hydrocarbon-fired heater as compared to the fuel gas fired heaters proposed by MBFP. Therefore, the NO<sub>x</sub> reductions for the auxiliary boiler and fired heaters at the MBFP facility would receive comparatively less NO<sub>x</sub> reduction benefit with the application of SCR, and the cost would not be warranted.

**Selective Non-Catalytic Reduction (SNCR)**

SNCR is a post-combustion NO<sub>x</sub> control technology where ammonia or urea is injected into the exhaust to react with NO<sub>x</sub> to form nitrogen and water without the use of a catalyst. Use of this technology requires uniform mixing of the reagent and exhaust gas within a narrow high

temperature range (1,600°F–1,900°F). Operations outside of this temperature range will significantly reduce removal efficiencies and may result in ammonia emissions or increased NO<sub>x</sub> emissions. The auxiliary boiler and fired process heaters exhaust temperatures range from approximately 700°F to 900°F. Thus, SNCR is not technically feasible for the proposed auxiliary boiler or fired process heaters.

#### **Non-Selective Catalytic Reduction (NSCR)**

NSCR is a post-combustion control technology that utilizes a catalyst to reduce NO<sub>x</sub> emissions under fuel-rich conditions. The technology has been utilized in the automobile industry and for reciprocating engines. A RBL search was performed over the previous 10-year period for other gaseous fuels and gaseous fuel mixtures in boilers and process heaters less than 100 MMBtu/hr (Process Type 13.390). The search encompassed 24 facilities and 110 processes. Application of NSCR was not identified for process heaters or boilers less than 100 MMBtu/hr in this search. NSCR technology requires a fuel-rich environment for NO<sub>x</sub> reduction, which will not be available in the proposed auxiliary boiler or fired heaters. Therefore, NSCR is not a technically feasible for the proposed auxiliary boiler or fired heaters.

#### **EMx™**

EMx™ is a post-combustion control technology that utilizes a single catalyst to minimize CO, VOC, and NO<sub>x</sub> emissions. Installations of the technology have been limited to small natural gas combustion turbine applications. Recent analyses by state agencies have determined that the technology is currently not feasible for syngas/tail gas fired process heater applications. For example, the Oregon Department of Environmental Quality (ODEQ) concurred that EMx™ was not technically feasible for a proposed 140 MMBtu/hr auxiliary boiler project. ODEQ also noted that a small boiler (4.2 MMBtu/hr) project in California installed an EMx™ system, but the South Coast Air Quality Management District determined application of the technology could not demonstrate the necessary emission reductions. Based on these determinations and the limited scope of commercial installations, EMx™ is not technically feasible for the proposed auxiliary boiler or fired heaters.

#### **Rank Control Technologies**

SCR and the use of low NO<sub>x</sub> burner technology were the only technically feasible control options identified for reducing NO<sub>x</sub> emissions. The only applications of SCR identified by the RBL search were located in an area where the SIP influenced the NO<sub>x</sub> reductions which were more stringent than BACT. The total potential NO<sub>x</sub> emissions proposed at the MBFP facility during normal operations for all heaters and the auxiliary boiler combined are 4.11 tpy. The use of SCR is not warranted at the Plant based on the relatively small amount of aggregate NO<sub>x</sub> emissions from all of the fired process heaters.

#### **Evaluate Control Options**

Low NO<sub>x</sub> burner technology has historically been selected as BACT for syngas/tail gas fired process heaters and provide good NO<sub>x</sub> control through prevention of NO<sub>x</sub> formation. As discussed earlier in this section, SCR is not warranted for these process heaters due to the small amount of NO<sub>x</sub> emissions from the heaters.

#### **Select NO<sub>x</sub> Best Available Control Technology**



## SECTION FOUR

## Best Available Control Technology

The use of low NO<sub>x</sub> burner technology is proposed as BACT for NO<sub>x</sub> emissions from the proposed auxiliary boiler and fired process heaters. The proposed BACT emission limits for each unit are presented below for operation on both fuel gas mixture and natural gas.

### *Proposed NO<sub>x</sub> BACT Limits:*

Auxiliary Boiler: 0.036 lb/MMBtu (fuel gas mixture)

50.0 lb/MMscf (natural gas)

Catalyst Regen Heater: 30 lb/MMscf (fuel gas mixture)

Reactivation Heater: 30 lb/MMscf (fuel gas mixture)

50 lb/MMscf (natural gas)

HGT Reactor Charge Heater: 30 lb/MMscf (fuel gas mixture)

50 lb/MMscf (natural gas)

### 4.4.2 CO and VOC BACT Analysis for the Fired Heaters and Boiler

Potential CO and VOC emissions are due to incomplete combustion that is typically a result of inadequate air and fuel mixing, a lack of available oxygen, or low temperatures in the combustion zone. Fuel quality and good combustion practices can limit CO and VOC emissions. Good combustion practice has commonly been determined as BACT for syngas/tail gas fired heaters. Post-combustion control technologies using catalytic oxidation have also been used in some processes to reduce CO and VOC emissions.

#### *Identify Control Technologies*

The following CO and VOC control technologies were evaluated for the proposed fired heaters.

#### Combustion Process Controls

Good Combustion Practices

#### Post-Combustion Controls

Oxidation Catalyst

EMx™

#### *Evaluate Technical Feasibility*

##### **Good Combustion Practices**

Good combustion practices include the use of operational and design elements that optimize the amount and distribution of excess air in the combustion zone to ensure complete combustion. Good combustion practice has historically been determined as BACT for CO and VOC emissions from syngas-fired process heaters and is a technically feasible control strategy for the proposed auxiliary boiler and fired heaters.

**Oxidation Catalyst**

Catalytic oxidation is a post-combustion control technology that utilizes a catalyst to oxidize CO and VOC into CO<sub>2</sub> or H<sub>2</sub>O. The technology has most commonly been applied to natural gas fired combustion turbines. No examples were identified where oxidation catalyst technology has been applied to a syngas-fired process heater. Because of the low potential CO and VOC emissions without an oxidation catalyst during normal operations (less than 6.92 tpy CO and less than 0.57 tpy VOC from the auxiliary boiler and all heaters combined), the use of catalytic oxidation technology is determined not to be warranted due to the small emission reduction potential.

**EMx™**

EMx™ technology is discussed in the NO<sub>x</sub> BACT analysis and determined not to be technically feasible.

**Rank Control Technologies**

Good combustion practice is the only feasible control strategy identified, and has historically been selected as BACT for CO and VOC emissions from syngas/tail gas fired process heaters.

**Evaluate Control Options**

Good combustion practice is the only feasible control strategy identified, and has historically been selected as BACT for CO and VOC emissions from syngas/tail gas fired process heaters.

**Select CO and VOC Control Technology**

The use of good combustion practices is proposed as BACT for potential CO and VOC emissions from the auxiliary boiler and proposed process heaters. The BACT limits for CO and VOC emissions are proposed below.

**Proposed CO BACT Limit:**

Auxiliary Boiler: 0.037 lb/MMBtu (fuel gas mixture)  
84.0 lb/MMscf (natural gas)  
Catalyst Regen Heater: 84.0 lb/MMscf (fuel gas mixture)  
Reactivation Heater: 84.0 lb/MMscf (fuel gas mixture)  
84.0 lb/MMscf (natural gas)  
HGT Reactor Charge Heater: 84.0 lb/MMscf (fuel gas mixture)  
84.0 lb/MMscf (natural gas)

**Proposed VOC BACT Limit:**

Auxiliary Boiler: 0.004 lb/MMBtu (fuel gas mixture)  
5.50 lb/MMscf (natural gas)  
Catalyst Regen Heater: 5.50 lb/MMscf (fuel gas mixture)  
Reactivation Heater: 5.50 lb/MMscf (fuel gas mixture)  
5.50 lb/MMscf (natural gas)  
HGT Reactor Charge Heater: 5.50 lb/MMscf (fuel gas mixture)  
5.50 lb/MMscf (natural gas)

**4.4.3 SO<sub>2</sub> BACT Analysis for the Fired Heaters and Boiler**

The auxiliary boiler and fired heaters oxidize any residual sulfur compounds present in the fuel gas mixture into SO<sub>2</sub>. The control of SO<sub>2</sub> emissions is most directly associated with low-sulfur fuel.

***Identify SO<sub>2</sub> Control Technologies***

The following SO<sub>2</sub> control technologies were evaluated for the proposed process heaters.

**Pre-Combustion Control**

Lower Sulfur Fuels

**Post-Combustion Control**

Flue Gas Desulfurization

***Evaluate Technical Feasibility*****Low Sulfur Fuels**

Potential SO<sub>2</sub> emissions are directly related to the sulfur content of fuels. The gas fed to the Methanol Unit requires less than 0.1 ppmvd, and therefore the SELEXOL<sup>®</sup> process in the AGR unit and sulfur beds will be used to achieve this low sulfur level. All fuel gas used throughout the plant is first desulfurized in the AGR unit, and therefore contains less than 0.1 ppmvd sulfur (expressed as H<sub>2</sub>S). The concentration in the exhaust of each fired heater will be less than 0.2 ppmvd. Minimizing fuel sulfur content through the use of natural gas (startup only) or low sulfur fuel gas has been determined to be BACT for many combustion processes, including fired process heaters. Therefore, using low-sulfur-fuel is a technically feasible control technology.

**Flue Gas Desulfurization**

FGD is a post-combustion SO<sub>2</sub> control technology that reacts an alkaline solution with SO<sub>2</sub> in the exhaust gas. FGD systems are more readily applied to high SO<sub>2</sub> concentration gas streams, such as with a pulverized coal unit. FGD has not been applied to small process heaters due to the low SO<sub>2</sub> concentrations of exhaust streams associated with tail gas combustion. Therefore, FGD technology is not technically feasible for the proposed fired heaters.

***Rank Control Technologies***

The use of low-sulfur fuels is the only technically feasible SO<sub>2</sub> control technology identified for the proposed fired heaters.

***Select SO<sub>2</sub> Best Available Control Technology***

The use of low sulfur fuels (tail gas) is proposed as BACT for SO<sub>2</sub> emissions from the proposed auxiliary boilers and fired heaters. As emissions of SO<sub>2</sub> are negligible, BACT limits are not proposed for the auxiliary boiler and fired heaters.

**4.4.4 Particulate Emissions BACT Analysis for the Fired Heaters and Boiler**

Fuel quality and combustion efficiency are key drivers affecting the quantity and disposition of potential particulate emissions. In some processes, post-combustion control technologies can also be used to reduce particulate.

***Identify Control Technologies***

The following particulate emissions control technologies were evaluated for the proposed auxiliary boiler and fired process heaters.

**Pre-Combustion Control**

Clean Fuels

Good Combustion Practices

**Post-Combustion Control**

Electrostatic Precipitation

Baghouse

***Evaluate Technical Feasibility*****Clean Fuels**

Fuels containing ash have the potential to produce particulate matter emissions. Additionally, fuels containing sulfur have the potential to produce sulfur compounds that may form condensable particulate matter emissions. The fuel gas mixture consumed by the proposed auxiliary boilers and fired heaters will contain negligible amounts of particulate matter and is considered a low sulfur fuel. Therefore, the use of clean fuels is a technically feasible control technology for the process heaters.

**Good Combustion Practice**

The use of good combustion practice is a technically feasible technology that can minimize the potential particulate emissions associated with incomplete combustion.

**Electrostatic Precipitation**

ESP is a post-combustion particulate emissions control most readily applied to large volume gas streams containing high particulate concentrations. No examples have been found where an ESP has been applied to a syngas/tail gas fired process heater due to the reduced volume and minimal particulate concentration of the associated exhaust gas stream. Therefore, ESP is not technically feasible for the auxiliary boiler and proposed process heaters.

**Baghouse**

A baghouse is a post-combustion control technology that utilizes a fine mesh filter to remove particulate emissions primarily from large volume gas streams containing high particulate concentrations. No examples have been found where a baghouse has been applied to a syngas/tail gas fired process heater due to the reduced volume and minimal particulate

concentration of the associated exhaust gas stream. Therefore, baghouse technology is not technically feasible for the auxiliary boiler and proposed process heaters.

#### ***Rank Control Technologies***

The use of clean fuels and good combustion practices are the only technically feasible control technologies identified.

#### ***Select Particulate Emissions Control Technology***

The use of clean fuels and good combustion practices has been proposed as BACT. The proposed PM BACT limit is presented below.

##### ***Proposed PM BACT Limit:***

Auxiliary Boiler: 0.005 lb/MMBtu (fuel gas mixture)

7.60 lb/MMscf (natural gas)

Catalyst Regen Heater: 7.60 lb/MMscf (fuel gas mixture)

Reactivation Heater: 7.60 lb/MMscf (fuel gas mixture)

7.60 lb/MMscf (natural gas)

HGT Reactor Charge Heater: 7.60 lb/MMscf (fuel gas mixture)

7.60 lb/MMscf (natural gas)

Please note that these emission limits were all calculated with emission factors from EPA's AP-42 "Compilation of Air Pollutant Emission Factors" document. AP-42 particulate emissions from fuel gas firing have been demonstrated to underestimate actual emissions in some cases. At this time, it cannot be determined if the particulate emissions presented here are underestimated for these process heaters based on the use of AP-42 factors. All heater particulate emission limits should be verified through stack testing, and the construction permit should be modified to reflect the more accurate emission factors obtained through testing.

#### **4.4.5 Startup Emissions BACT Analysis for the Fired Heaters and Boiler**

Fired heater startup emissions are quantified separately from normal operating emissions. During startup and upset conditions, natural gas may be used, although the fuel gas mix will still be used when available. To satisfy BACT during startup and upset operating conditions, the auxiliary boiler and fired heaters will be limited to 1,000 hours per year of natural gas firing for all startup operations including initial startup and other startup modes. The duration of the startups will also be minimized to the best extent possible for each unit. Alternatively, natural gas may be used as a backup fuel that will not increase the emissions over using fuel gas firing.

#### **4.5 STORAGE TANK CONTROL TECHNOLOGY REVIEW**

Eight gasoline product tanks are proposed for the facility, along with two methanol storage tanks, one "heavy gasoline" intermediate product tank, and one slop tank. Additionally, several smaller storage tanks and LPG storage bullet tanks are proposed. Table 4.3 lists all proposed storage tanks for the facility. VOC and HAP emissions from the storage tanks, with the exception of the closed-system LPG bullets, will occur as a result of headspace vapor displacement during filling

operations (working losses) and from diurnal temperature variations and solar heating cycles (breathing losses).

The proposed gasoline product, methanol, heavy gasoline, and slop storage tanks will be designed with internal floating roofs (IFRs), submerged fill, white exterior surfaces, and will meet NSPS Subpart Kb (Standards of Performance for Volatile Organic Liquid Storage Vessels (including Petroleum Liquid Storage Vessels) for Which Construction, Reconstruction, or Modification Commenced After July 23, 1984) requirements. The proposed smaller tanks will store water and low vapor-pressure chemicals and will be fixed roof design, with no IFRs. Because emissions from these smaller tanks will be insignificant, they are not addressed in this BACT analysis. Similarly, since the LPG bullets will be constructed as a closed system with no vents to atmosphere, they are not addressed in this analysis.

### ***Identify VOC and HAP Control Technologies***

The following VOC and HAP control technologies were evaluated for the proposed methanol, gasoline, and slop storage tanks.

1. Operate tanks under pressure, as closed systems.
2. Construct tanks with a fixed or dome roof, with vapor collection routed to fuel gas system or process system.
3. Construct tanks with a fixed or dome roof, with vapor collection routed to a control device.
4. Construct tanks with an external floating roof (EFR).
5. Construct tanks with an internal floating roof (IFR) in combination with a fixed roof.

### ***Evaluate Technical Feasibility***

#### **Operate Storage Tank Under Pressure**

Operating the storage tanks under pressure as closed systems is an inherently less-polluting process configuration because it eliminates working and breathing losses. However, this option is suitable only for materials that are gases at atmospheric pressure and temperature such as propane and butane. (Note, the proposed LPG storage tanks for the facility will be pressurized bullets, operating as closed systems.) Therefore, this option is not technically feasible for the liquid storage tanks under review.

#### **Fixed or Dome Roof with Vapors Routed to Fuel Gas System or Process System**

This option can also be considered to be an inherently less-polluting process configuration. An inert gas 'blanket' would be required for this option in order to ensure the tank vapor space remains outside of explosive limits. Design and operation of the gas blanket could present considerable engineering challenges, as the system and tanks must be designed and operated to prevent any under-pressure or over-pressure scenarios that could result in catastrophic tank failure. Generally, the practice of operating large storage tanks such as these (storing volatile liquid product) with a vapor space is not common due to the potential safety issues and the chance for an explosive atmosphere to be created at some point in the vapor system. The industry standard, from a safe operating perspective, for large gasoline and other volatile liquids is a floating roof.

For this control option, the vapor stream must be directed to a compatible fuel gas system or process system in order to protect plant operations and system integrity. Due to the inert gas blanket required as part of this option's design, no compatible fuel gas or process gas streams are available in the proposed facility to receive the vent stream. Based on this, in addition to the potential safety issues associated with operating a vapor system in these storage tanks, the option is considered technically infeasible.

#### **Fixed or Dome Roof with Vapors Routed to a Control Device**

This control option is very similar to the previous one, except that the vent stream would be routed to a control device, such as a thermal oxidizer, instead of a fuel gas or other process system. Similar safety issues are presented with this option as with the previous option, with regard to the vapor space in the tank and design/operation of the vapor system. However, this option is considered technically feasible, because a final destination for the vent stream is presented and available.

A certain amount of product would be "lost" to the vapor space with this option, as with the previous option. With a control device such as a thermal oxidizer, the "lost" product would not be recoverable. An advantage to the previous option is that "lost" product can be recovered through re-routing to a fuel gas or process system. Non-recoverable, lost product could present a significant economic disadvantage for this control option.

#### **External Floating Roof (EFR) or Internal Floating Roof (IFR)**

Floating roof technology is the prevalent emission control technology for large tanks storing volatile liquids. Both EFR and IFR technology provide for minimal product loss (i.e., emission prevention) as well as improved safety over fixed roof tanks. This option is technically feasible for the proposed storage tanks.

#### **Rank Control Technologies**

The three technically feasible control options are ranked as follows.

1. IFR, in combination with a fixed roof
2. Fixed or dome roof with vapors routed to a control device
3. EFR

All three technically feasible options will meet NSPS Subpart Kb requirements for VOC control. However, of the three technically feasible options, the EFR is considered to be the least effective for VOC and HAP emission control. An IFR, in combination with a fixed roof, provides better emission control for volatile liquids and is generally preferred over EFRs in similar applications.

Constructing the storage tanks with a fixed roof and a vapor collection system with the vent stream routed to a control device would also provide high control efficiency, but the option has a significant disadvantage in that operation of a thermal oxidizer will result in additional emissions from the combustion process ( $\text{NO}_x$  and CO). Based on this negative environmental impact, in addition to the safety concerns discussed earlier, this option is ranked second, below the IFR option.

Therefore, the option to construct the tanks with IFRs in combination with fixed roofs is considered the most effective control option.

**Select Best Available Control Technology**

An internal floating roof (IFR), in combination with a fixed roof, is proposed as BACT for the gasoline product, methanol, heavy gasoline, and slop product storage tanks. Table 4.3 presents detailed capacity and product data for each of the proposed storage tanks.

**Table 4.3 – Storage Tanks Summary**

Tank Name	Tank No.	No. of Tanks	Liquid Capacity per Tank (Gallons)	Roof Type	NSPS Kb Applicable
Methanol Tanks	TBD	2	6,341,984	IFR	Yes
Gasoline Product Tanks	TBD	8	6,341,984	IFR	Yes
Heavy Gasoline Tank <sup>1</sup>	TBD	1	4,763,841	IFR	Yes
Off-Spec Gasoline Tank	TBD	1	5,000	IFR	N/A (size)
Off-Spec Methanol Tank	TBD	1	5,000	IFR	N/A (size)
Slop Tank	TBD	1	7,000	IFR	N/A (size)
<b>Tanks with Insignificant Emission Rates</b>					
Gray Water Tank	03T-002	1	TBD	FR	No
Slurry Additive Tank	03T-003	1	TBD	FR	No
Mill Discharge Tank	01T-104	1	TBD	FR	No
Slurry Tank	01T-105	1	TBD	FR	No
Injector Coolant Tank	02T-001	1	TBD	FR	No
Settler	03T-001	1	TBD	FR	No
Filter Feed Tank	03T-004	1	TBD	FR	No
Filtrate Tank	03T-005	1	TBD	FR	No
Glycol Storage Tank	TBD	1	4,000	FR	No
Sulfur Storage	TBD	2	5,000	FR	No

1. "Heavy" gasoline is estimated to have RVP of 3-5 psia.

**4.6 MATERIAL HANDLING CONTROL TECHNOLOGY REVIEW**

The material handling conveyer will be fully enclosed to prevent wind blown fugitive dust. Transfer points will be controlled with fogger and passive engineering design at transfer points. This technology has been successfully used in other coal applications in Wyoming. On the MBFP Facility site there will be covered coal storage for approximately 8 hours of use.

Additionally, the coal handling operations will be subject to and will comply with the NSPS for Coal Preparation Plants (Subpart Y), as applicable.



**4.7 PROCESS FUGITIVE EMISSIONS CONTROL TECHNOLOGY REVIEW**

Fugitive VOC, HAP, and hydrogen sulfide (H<sub>2</sub>S) emissions will be generated from potential leaking process equipment, primarily downstream of the coal preparation and gasification portions of the facility (SELEXOL acid gas removal, CO<sub>2</sub> recovery, sulfur recovery, methanol synthesis, gasoline synthesis, etc.). Additionally, fugitive ammonia emissions will be generated from potential equipment leaks in the ammonia storage and feed equipment used for the proposed SCR system (turbine NO<sub>x</sub> control). Note that the number of piping components in ammonia service will be very small in comparison to the number of other potential leaking components at the proposed facility.

VOC and HAP emissions from equipment leaks were estimated using fugitive leak emission factors from EPA Document No. EPA-453/R-95-017, November 1995 ("Protocol for Equipment Leak Emission Estimates"). Control efficiencies reflecting a monthly leak detection program were used in the calculation, assuming a leak definition value of 10,000 ppmv for each component. Total facility estimated potential VOC emissions from equipment leaks are 71 tons per year, and total facility estimated potential HAP emissions are 21 tons per year.

***Identify VOC and HAP Control Technologies***

The only available control technology for comprehensively addressing equipment leak fugitive emissions is a structured Leak Detection and Repair (LDAR) program in which certain piping components and equipment are routinely inspected for leaks, and components found to be leaking in excess of stated thresholds are repaired in a timely manner. The effect of a well-implemented LDAR program is reduced VOC and HAP emission rates due to improved maintenance and repair. LDAR programs are established as BACT in many recent RBLC determinations.

***Select Best Available Control Technology***

A formal, structured LDAR program is proposed as BACT for components in VOC service. Records will be maintained for all leak inspections and necessary repair work.

Additionally, audio/visual/olfactory (AVO) detection is proposed for equipment potentially leaking hydrogen sulfide or ammonia. Both chemicals have low odor thresholds, and plant personnel should be able to easily detect any leaking components under routine plant operations. Leaking equipment discovered through AVO detection will be repaired in an expeditious manner in order to reduce emissions and remove potential safety issues.

**4.8 SULFUR RECOVERY UNIT (SRU) CONTROL TECHNOLOGY REVIEW**

The Sulfur Recovery Unit (SRU) is designed to process acid gas streams from the SELEXOL<sup>®</sup> acid gas removal system and Plant process into an elemental sulfur product. SRU tail gas is typically directed to a tail gas treatment unit designed to remove SO<sub>2</sub> from the tail gas before the tail gas is vented to atmosphere. Typical SRU design also incorporates a thermal oxidizer, also called a tail gas incinerator, to provide efficient destruction of the tail gas stream after it exits the tail gas treatment unit. In the event of a malfunction with the SRU or tail gas incinerator, or during times of cold startup, the tail gas stream may be temporarily diverted to a flare in lieu of

the tail gas incinerator. The pollutant of concern for SRUs is SO<sub>2</sub>, although emissions of other criteria pollutants may result from the combustion process.

#### *Identify SO<sub>2</sub> Emission Control Technologies*

Potential control technologies for the SRU tail gas stream during times of normal operation include the following:

1. LP Flare
2. Thermal Oxidizer (Tail Gas Incinerator)
3. Re-routing Tail Gas to Process

#### *Evaluate Technical Feasibility*

The LP Flare is proposed as a low-pressure flare for the facility and will intermittently receive vent streams from various processes throughout the facility, in addition to any vents from the SRU. Control efficiency for the flare is estimated at 98%.

As mentioned earlier, a tail gas incinerator is a typical control device for SRUs and would be dedicated to the SRU tail gas, with a supplemental fuel gas or natural gas. Control efficiency is estimated between 98-99%.

Re-routing the tail gas back to the process would involve routing the tail gas to a point upstream of the H<sub>2</sub>S absorption tower in the SELEXOL<sup>®</sup> acid gas removal process and would allow the stream to be reprocessed rather than being combusted and destroyed. This option results in no emissions during normal operation since nothing is emitted to the atmosphere, and therefore it has 100% control efficiency.

For the proposed Plant, all three possible control options are technically feasible during times of normal operation. However, during times of startup, shutdown, or malfunction (SSM), neither the thermal oxidizer nor re-routing the tail gas stream are considered technically feasible options, due to the variability of gas stream flowrate and composition during these times. The LP Flare is the only technically feasible option for SSM conditions.

#### *Select Best Available Control Technology*

Of the three technically feasible control options, re-routing the tail gas back into the process at an upstream point provides 100% control, and is therefore ranked higher than the LP Flare or tail gas incinerator options. BACT is chosen to be re-routing the tail gas stream during times of normal operation, with the LP Flare employed only as needed during times of SSM operations.

### **4.9 CARBON DIOXIDE VENT STACK (STARTUP OPERATIONS ONLY)**

During initial startup operations and subsequent warm start operations, off-specification CO<sub>2</sub> will be vented to the atmosphere. This exhaust will contain some small amount of CO and VOC (primarily COS). Elements have been incorporated in the design and operating procedures to minimize the frequency and duration of venting this gas stream to the atmosphere. The facility is being designed so that this venting will not occur during load transitions during normal

operations. Another factor is that this carbon dioxide stream is a product. Design elements that maximize the reliability of the carbon dioxide stream and minimize startup, shutdown, and malfunction periods will reduce the frequency and duration of venting events. The venting is only anticipated for a few days during initial startup (approximately 250 hrs/yr for the first year). Since the plant will be started up at reduced load, the venting will be at a reduced rate (approximately 25% of the normal process stream flow rate). Venting is anticipated for only a few hours for subsequent warm starts, not to exceed 50 hrs/yr. Again, the venting would be at a reduced load (approximately 50% of the normal process stream flow rate).

Catalytic oxidation is not technically feasible based on the low temperature of the vent stream, approximately 100°F. Based on the temperature and large flow rate, an extremely large amount of energy would be necessary to oxidize the CO with a thermal oxidizer, and may not be possible due to the size of the stream, low temperature, and high concentration of CO<sub>2</sub> in the stream. RBLC ID WY-0042 contained a process identified as "Vent, CO<sub>2</sub> Product" where incineration was not feasible due to CO<sub>2</sub> concentration in the gas. RBLC ID WY-0056 contained a process identified as "CO<sub>2</sub> Product Vent, Train III" that also vented uncontrolled.

The total annual proposed CO emissions to be permitted from the CO<sub>2</sub> stack are 275 tpy for the initial year of operation. Subsequent years will be limited to 74 tpy of CO. The proposed VOC emissions are 0.02 tpy for the first year and 0.01 tpy for subsequent years. Based on the limited operating time and resultant emissions, further controls are not warranted. Thus, an optimized process design is considered BACT for this process vent.

#### **4.10 GASIFIER PREHEATING CONTROL TECHNOLOGY REVIEW (STARTUP OPERATIONS ONLY)**

During the initial startup operations, or if new refractory is in place in a gasifier, a designated 21 MMBtu/hr natural gas burner is used to preheat the refractory lining prior to commencing tail gas production. Potential emissions from the natural gas combustion in the gasifiers is exhausted from a preheat vent located on each gasifier. The primary potential emissions from the gasifier preheat vents are NO<sub>x</sub> and CO. Each gasifier preheat vent has a potential to emit less than 1 ton per year of NO<sub>x</sub> and CO as discussed in the emission inventory. Emissions of VOC and particulate will also be relatively small based on the short operating time, approximately one week for each gasifier, for initial startup (and refractory replacement) only. Subsequent startup operations will be warm starts and will not include this step. The maximum hours per year proposed for the gasifier preheaters are 500 hours per year per heater, for a total of 2,500 hours per year. Good combustion controls that optimize burner efficiency will minimize potential NO<sub>x</sub>, CO, VOC and particulate emissions. Because a low-sulfur-fuel (natural gas) is being used for preheating, the potential emissions of SO<sub>2</sub> will also be small.

The use of a low-sulfur-fuel, restricted operating conditions, and good combustion practices are proposed as BACT for each of the five (5) gasifier preheat burners. Table 4.4 shows the proposed BACT emission rates for each gasifier preheater.

**Table 4.4 – Gasifier Preheater BACT Analysis Summary**

Pollutant	Proposed BACT	Proposed BACT Emission Limits (emission limits are per gasifier preheater)
NO <sub>x</sub>	Low Sulfur Fuel Good Combustion Practices Restricted Operation (startup only)	NO <sub>x</sub> Limit: 0.26 tpy
SO <sub>2</sub>		SO <sub>2</sub> Limit: <0.01 tpy
CO		CO Limit: 0.43 tpy
VOC		VOC Limit: 0.03 tpy
PM		Particulate Limit: 0.04 tpy (PM <sub>10</sub> - filterable)

**4.11 BLACK-START GENERATOR CONTROL TECHNOLOGY REVIEW (STARTUP OPERATIONS ONLY)**

The proposed Plant will include three (3) 1.6 MW natural gas fired generators for use during startup. The generators will be used for commissioning and initial startup. Key utility systems such as instrument air, water supply and purification, firewater, and nitrogen will be made operational prior to initiating the startup sequence for the process. It is especially important that the flare system be ready for service before any flammable gas is present. Once critical utilities are in service, one of the three gas turbines is started on natural gas. This will produce enough power to displace the Black-Start generators. The primary potential emissions from the Black-Start generators are NO<sub>x</sub> and CO. Emissions of VOC and particulate will also be relatively small based on the short operating time and infrequent use (only initial startup and commissioning and upset conditions). The maximum hours per year proposed for the Black-Start generators are 250. Subsequent startup operations will be warm starts and are not anticipated to require firing of the Black-Start generators. Good combustion controls that optimize combustion efficiency will minimize potential NO<sub>x</sub>, CO, VOC and particulate emissions. Because natural gas is being used, the potential emissions of SO<sub>2</sub> will also be small. Additionally, these natural gas fired generators will also be subject to and will comply with the NSPS for Stationary Compression Ignition Combustion Engines (Subpart IIII), as applicable.

The use of a natural gas, restricted operating conditions, and good combustion practices are proposed as BACT for the three Black-Start generators. Table 4.5 shows the proposed BACT emission rates for each Black-Start generator.

**Table 4.5 – Black-Start Generator BACT Analysis Summary**

Pollutant	Proposed BACT	Proposed BACT Emission Limits (emission limits are per generator)
NO <sub>x</sub>	Natural Gas Fired Good Combustion Practices Restricted Operation (initial startup only)	NO <sub>x</sub> Limit: 0.80 tpy
SO <sub>2</sub>		SO <sub>2</sub> Limit: <0.01 tpy
CO		CO Limit: 1.93 tpy
VOC		VOC Limit: 0.72 tpy
PM		Particulate Limit: 0.0002 tpy (PM <sub>10</sub> - filterable)

**4.12 FIREWATER PUMP CONTROL TECHNOLOGY REVIEW (BACKUP OPERATIONS ONLY)**

The Firewater Pump is used to support emergency operations at the proposed facility. Potential emissions from the Firewater Pump are controlled by restricting the hours of operation, using good combustion practices, and using ultra-low-sulfur-fuel. Operation of the emergency Firewater Pump will be limited to emergency operating scenarios or required testing by the manufacturer. The Firewater Pump will operate no more than 500 hours per year. The design will incorporate manufacturer specifications that maximize the combustion efficiency and minimize potential emissions. Based on the limited operating time and resultant emissions, further controls are not warranted. This diesel-fired pump will also be subject to and will comply with the NSPS for Stationary Compression Ignition Combustion Engines (Subpart III), as applicable. Assuming a displacement of <30 liters per cylinder, if model year is 2009 or after NSPS III would apply.

Additionally, ultra-low-sulfur diesel fuel containing less than or equal to 15 ppm sulfur will be used. Good combustion practices, restricted annual operations, and ultra-low-sulfur fuel are proposed as BACT. Table 4.6 shows the proposed BACT emission rates for the emergency Firewater Pump.

**Table 4.6 – Emergency Firewater Pump BACT Analysis Summary**

Pollutant	Proposed BACT	Proposed BACT Emission Limits
NO <sub>x</sub>	Restricted Operation (<500 hr/yr) Low Sulfur Fuel Good Combustion Practices	NO <sub>x</sub> Limit: 1.51 tpy
SO <sub>2</sub>		SO <sub>2</sub> Limit: <0.01 tpy
CO		CO Limit: 0.09 tpy
VOC		VOC Limit: 0.34 tpy
PM		Particulate Limit: 0.02 tpy (PM <sub>10</sub> -filterable)

**4.13 MERCURY EMISSION REDUCTION**

Syngas exiting the gasifiers contains some mercury. This mercury must be removed before the syngas enters the Methanol Synthesis Unit. Two mercury guard beds will be operated at the Plant and are expected to achieve 99.98% removal of mercury. The cost of the planned mercury removal system is estimated to be \$235,164 per ton of mercury removed, as shown in Appendix G.

MBFP requests a mercury emission rate of 0.02 µg/Nm<sup>3</sup>. This emission rate results in mercury emissions of no more than 6.5×10<sup>-5</sup> tpy (0.129 lb/yr), which is less than the applicable NSPS requirements in 40 CFR Part 60, Subpart Da that mandate a mercury emission limit of 20×10<sup>-6</sup> lb/MWh.

**4.14 MINE LONG-TERM COAL STORAGE**

The Mine will have two coal storage areas. The first is a 300,000-ton dead storage (emergency stockpile) and the second is a 300,000 ton active storage area. The emergency stockpile will be compacted and sealed to prevent wind erosion and spontaneous combustion. Since there will be no particulate emissions associated with this stockpile once it is constructed, it has not been included in this analysis.

Three scenarios were evaluated for the active coal storage. There are:

1. Stacking tubes located on the surface
2. Stacking tubes located in the pit excavated
3. Covered slot storage

The BACT analysis for the active storage for performed by IML Air Science (Sheridan, WY). The complete analysis is in Appendix F.

***Identify Particulate Emission Control Technologies***

The first two scenarios differ in the placement of the stacking tubes. Scenario 2 places the stacking tube on the pit floor on the previously mined surface coal, with the excavated spoils placed in a large berm on the west and north sides of the pit. This configuration is intended to reduce storage pile erosion and resulting PM<sub>10</sub> emissions, by sheltering the pile from prevailing winds.

The third scenario would be to construct a covered storage area (slot storage or coal barn).

***Evaluate Technical Feasibility***

The control strategies described above as Scenarios 2 and 3 have been implemented in Wyoming and in other parts of the country. Therefore, both are considered technically feasible.

***Rank Control Technologies***

The covered storage (Scenario 3) would result is zero particulate emissions (100% control effectiveness). The sheltered stacking tubes have an estimated 23% control effectiveness on the particulate emissions resulting in annual emissions of 60 tpy (Scenario 1 was estimated to be approximately 78 tpy).

An economic analysis was conducted on the incremental control cost between Scenarios 2 and 3. The incremental control cost between the two scenarios is \$6,902 per ton removed.

***Evaluate Control Technologies***

Although the covered storage has a greater control effectiveness, the economic analysis shows the cost for the scenario is not financially viable.

## **SECTION FOUR**

## **Best Available Control Technology**

---

### ***Select Particulate Emissions Control Technology***

Due to the negative economic impact of the covered storage, the next most effective control option (sheltered stacking tubes) was selected.

This section analyzes the state and federal air quality regulations that are potentially applicable to the Plant and Mine. This regulatory summary is not intended to provide a detailed explanation of all compliance requirements associated with applicable regulations.

**5.1 WYOMING AIR QUALITY REGULATIONS**

This section discusses the relevant Wyoming Air Quality Standards and Regulations (WAQS&R). MBFP will comply with all applicable requirements within WAQS&R.

**5.1.1 Chapter 2 Ambient Standards**

The Wyoming Ambient Standards set limits deemed necessary to protect public health and welfare. Table 5.1 compares the Wyoming Ambient Standards to the National Ambient Air Quality Standards (NAAQS). For many pollutants, Wyoming's ambient air quality standards are identical to national standards. However, the state has set standards for some additional pollutants.

With regard to the NAAQS, the Plant would be located within an area that is designated as attainment (or unclassifiable) for each criteria pollutant.

**Table 5.1 – Ambient Air Quality Standards**

Pollutant	Averaging Time	WAQS&R (µg/m <sup>3</sup> )	NAAQS (µg/m <sup>3</sup> )
PM <sub>10</sub>	24-hour	150 <sup>b</sup>	150 <sup>a</sup>
	Annual	50 <sup>f</sup>	---
PM <sub>2.5</sub>	24-hour	65 <sup>d</sup>	35 <sup>c</sup>
	Annual	15 <sup>f</sup>	15 <sup>e</sup>
NO <sub>2</sub>	Annual	100 <sup>f</sup>	100 <sup>f</sup>
SO <sub>2</sub>	3-hour	1,300 <sup>b</sup>	---
	24-hour	260 <sup>b</sup>	365 <sup>b</sup>
	Annual	60 <sup>f</sup>	80 <sup>b</sup>
CO	1-hour	40,000 <sup>b</sup>	40,000 <sup>b</sup>
	8-hour	10,000 <sup>b</sup>	10,000 <sup>b</sup>
Ozone	1-hour	---	235 <sup>h</sup>
	8-hour	157 <sup>g</sup>	157 <sup>g</sup>
H <sub>2</sub> S	1/2-hour	70 <sup>i</sup> (40 <sup>j</sup> )	70
SO <sub>3</sub> (Suspended sulfates)	30-day	250 mg/100 cm <sup>2</sup> /day	---
	Annual	500 mg/100 cm <sup>2</sup> /day	---



**Table 5.1 – Ambient Air Quality Standards**

Pollutant	Averaging Time	WAQS&R (µg/m <sup>3</sup> )	NAAQS (µg/m <sup>3</sup> )
Fluorides	12-hour	3.0	---
	24-hour	1.8	---
	7-day	0.5	---
	30-day	0.4	---
Lead	Quarterly	1.5	1.5

- <sup>a</sup> Not to be exceeded more than once per year on average over 3 years.
- <sup>b</sup> Not more than one exceedance per year.
- <sup>c</sup> Not to exceed the 3-year average of the 98th percentile of 24-hour concentrations.
- <sup>d</sup> Not to exceed the 98th percentile of 24-hour concentrations.
- <sup>e</sup> Not to exceed the 3-year average of the weighted annual mean.
- <sup>f</sup> Not to exceed the annual mean.
- <sup>g</sup> Not to exceed the 3-year average of the fourth-highest daily maximum 8-hour average ozone concentrations.
- <sup>h</sup> Applies only to limited areas (not applicable to this project).
- <sup>i</sup> Not to be exceeded more than 2 times per year.
- <sup>j</sup> Not to be exceeded more than 2 times per year in any 5 consecutive days.

**5.1.2 Chapter 3 General Emission Standards**

WAQS&R emission standards within Chapter 3 set forth requirements that are generally applicable to a wide variety of facilities. Applicable standards are summarized below.

**5.1.2.1 Section 2 Particulate Matter**

Opacity and fugitive dust are regulated under WAQS&R Chapter 3, Section 2. As a new facility, each new stationary source at the Plant and Mine may not exceed 20 percent opacity [WAQS&R Chapter 3, §2(a)]. However, brief exceedances of the 20 percent opacity limit are allowed in certain cases. An opacity of up to 40 percent is allowed for a period or periods aggregating to not more than 6 minutes in any hour [WAQS&R Chapter 3, §2(e)].

The firewater pump diesel engine would be subject to a 30 percent opacity limit except during periods not exceeding 10 consecutive seconds. This limit generally does not apply to a reasonable period of warmup following a cold start or when undergoing repairs and adjustment following a malfunction [WAQS&R Chapter 3, §2(d)].

Particulate emissions from process sources are limited by WAQS&R Chapter 3, §2(g). Coal handling, primarily movement of coal from the coal storage area, will be subject to this standard, which allows emissions up to the limit calculated by the following equation:

$$E = 17.31 P^{(0.16)}$$

Where:

E = Emissions (lb/hr)

P = Process weight (ton/hr)

Based on 8,000 TPD (333.3 ton/hr) of dry coal feed, the emission limit would be 43.84 lb/hr. Particulate emissions from coal handling will be far less than this due to the fogging system.

Fugitive dust from coal handling and storage at the Mine will be controlled by using a fogging system in order to comply with emission standards for material handling and storage at WAQS&R Chapter 3, §2(f)(ii). The IGL Plant will have about 8 hours of covered onsite storage for coal.

During construction of the Facility and associated portal areas, steps to minimize fugitive dust must be taken [WAQS&R Chapter 3, §2(f)(i)]. MBFP will require construction contractors to use control measures, such as frequent watering and/or chemical stabilization, on an as-needed basis to reduce fugitive dust emissions. In addition, contractors will be instructed to promptly remove mud or dirt that is tracked onto paved roadways [WAQS&R Chapter 3, §2(f)(i)].

#### **5.1.2.2 Section 3 Nitrogen Oxides**

The Plant will construct and operate several new gas fired fuel burning sources, such as the combustion turbines, boiler, and heaters. Under WAQS&R Chapter 3, §3(a)(i), NO<sub>x</sub> emissions from new gas fired fuel-burning equipment calculated as nitrogen dioxide (NO<sub>2</sub>) may not exceed 0.20 lb/MMBtu of heat input.

NO<sub>x</sub> emissions (calculated as NO<sub>2</sub>) from the fuel-oil burning Firewater Pump engine will be limited to 0.30 lb/MMBtu because it will have a heat input greater than 1.0 MMBtu/hr [WAQS&R Chapter 3, §3].

Internal combustion engines having a heat input of less than 200 MMBtu/hr are exempt from the NO<sub>x</sub> emission limits given above.

#### **5.1.2.3 Section 4 Sulfur Oxides**

Sulfur oxides (SO<sub>x</sub>) emission limits apply only to fuel burning equipment that is fueled with coal or oil. Consequently, the Firewater Pump is the only equipment subject to these standards. The Firewater Pump will be required to meet a 3-hour limit of 0.8 lb/MMBtu and a 30-day average of 0.8 lb/MMBtu [WAQS&R Chapter 3, §4(b)].

#### **5.1.2.4 Section 5 Carbon Monoxide**

Wyoming's air quality regulations do not include specific CO emission limits for stationary sources. There is, however, a general duty to prevent any exceedance of CO ambient standards [WAQS&R Chapter 3, §5]. Modeling results provided in Section 6 demonstrate that the Plant will meet this requirement.

#### **5.1.2.5 Section 6 Volatile Organic Compounds**

VOC emissions shall be limited through the application of BACT [WAQS&R Chapter 3, §6(b)]. In some cases, WDEQ regulates VOC emissions by mandating use of a flare. When a flare is required to control of VOC emissions from vapor blowdown, emergency relief systems, or VOC emissions generated from storage or processing operations, the flare shall not exceed a 20%

opacity emission standard [WAQS&R Chapter 3, §6(b)]. In addition, the flare must be a smokeless flare and must have either an automatic igniter or a continuous pilot.

#### **5.1.2.6 Section 7 Hydrogen Sulfide**

Some Plant process streams contain H<sub>2</sub>S and will be subject to WAQS&R Chapter 3, §7. Any exit process gas stream containing H<sub>2</sub>S that is discharged to the atmosphere must be vented, incinerated, flared or otherwise disposed of such that ambient SO<sub>2</sub> and H<sub>2</sub>S standards are not exceeded. Process streams containing H<sub>2</sub>S are treated within the Plant process to remove the sulfur. However, in the event of a malfunction, a stream containing H<sub>2</sub>S could be vented to a flare.

#### **5.1.2.7 Section 8 Asbestos Activities**

As a new facility, the Plant will minimize use of asbestos during facility construction. Furthermore, facility personnel are unlikely to remove asbestos-containing materials from the premises in the near future. However, activities that disturb asbestos would likely be subject to extensive compliance requirements found in WAQS&R Chapter 3, §8.

### **5.1.3 Chapter 6 Permitting Requirements**

#### **Section 2: Best Available Control Technology (BACT)**

Per the WAQS&R, Chapter 6, §2(c)(v), no permit to construct will be issued until it is demonstrated that BACT will be utilized, with consideration of the technical practicability and economic reasonableness of reducing or eliminating the proposed facility's emissions. In accordance with this requirement, and those imposed by the PSD Program discussed below, BACT analyses for all emission sources are presented in Section Four of this application.

#### **Section 3. Operating Permits**

Potential emissions from the Plant and Mine exceed the 100-tpy threshold for triggering operating permit requirements under Chapter 6, Section 3. These regulations implement the Title V Operating Permit Program required by federal law. Per the timeline established in the WAQS&R, Chapter 6, §3(c), an application for an operating permit will be submitted within twelve months of facility startup.

#### **Section 4. Prevention of Significant Deterioration**

Potential emissions from the Plant and Mine exceed the 100-tpy threshold for triggering PSD permitting. Therefore, extensive provisions within WAQS&R Chapter 6, Section 4 will apply to the facility. This permit application process, associated modeling, and installation and operation of BACT will satisfy PSD compliance requirements applicable to construction and initial operation of the facility. When facility or operational modifications are planned, PSD review may be required.

**5.1.4 Chapter 7 Monitoring Regulations**

Some emission units at the Plant will be subject to Compliance Assurance Monitoring (CAM) requirements in WAQS&R Chapter 7, Section 3. These regulations are based on the USEPA 40 CFR Part 64 CAM regulations. CAM requirements generally apply to each emission unit that meets all of the following criteria (with some exceptions).

- The emission unit is located at a facility that is subject to the Title V operating permit program.
- The emission unit uses a control device to achieve compliance with an emission limit and whose pre-controlled emission levels exceed major source thresholds under the Title V operating permit program.
- The unit is not subject to a New Source Performance Standard (NSPS) or a National Emissions Standard for Hazardous Air Pollutants (NESHAP) standard that was promulgated after November 15, 1990.

If the facility is subject to CAM, the affected emission units will be subject to additional monitoring, recordkeeping, and reporting requirements. In addition, the facility must prepare a CAM Plan for each affected unit. A thorough CAM applicability review and proposed CAM Plans will be submitted with the initial operating permit application.

**5.2 FEDERAL REGULATIONS**

The following discussion summarizes federal air quality regulations that are potentially applicable to the Plant. Due to the unique processes used by this facility, it does not fall into an industry-specific NSPS or NESHAP. However, some equipment at the facility will be subject to NSPS or NESHAP standards.

**5.2.1 New Source Performance Standards (NSPS)*****Subpart A: NSPS General Provisions***

Subpart A identifies a number of monitoring, recordkeeping, and notification requirements that generally apply to all NSPS Subparts. Additionally, Subpart A specifies that performance (source) tests must be conducted within 60 days of achieving the maximum production rate at which the source will be operated, but not later than 180 days after initial startup. Subpart A will apply in conjunction with any other applicable NSPS Subpart, unless otherwise noted in the specific NSPS.

***Subpart Da Electric Utility Steam Generating Unit NSPS***

The combustion turbines and HRSGs will not be subject to the Electric Utility Steam Generating Unit NSPS because the facility will not export power for sale. The facility is not an "electric steam generating unit," as defined in §60.41Da, which is the key applicability criteria for 40 CFR Part 60 Subpart Da.

**Subpart Db Industrial-Commercial-Institutional Steam Generating Unit NSPS**

The Auxiliary Boiler, which has a heat input of 66 MMBtu/hr, will be subject to Subpart Db emission limits for NO<sub>x</sub> and PM.

**Subpart J Petroleum Refinery NSPS**

As mentioned in Section One, the Plant is classified as a Crude Petroleum and Natural Gas facility (1311) that produces gas and hydrocarbon liquids through gasification. The minor or support activity is underground mining of bituminous coal (1222).

Although the facility produces gasoline, it does not do so using a refining process. Therefore, it is not subject to the Petroleum Refinery NSPS (40 CFR Part 60, Subpart J). The Plant does not meet the regulatory definition of a "petroleum refinery" because it does not engage in "... producing gasoline, kerosene, distillate fuel oils, residual fuel oils, lubricants, or other products through distillation of petroleum or through redistillation, cracking or reforming of unfinished petroleum derivatives [§60.2]."

**Subpart Kb Storage Vessels for Petroleum Liquids NSPS**

Eleven tanks, listed in Table 5.2, at the Plant are expected to be subject to the petroleum storage vessel NSPS due to their large size and volatile contents. Subpart Kb regulations set tank design and operation requirements, as well as ongoing inspection requirements. The planned IFR tank design will meet Subpart Kb requirements. Plant personnel will comply with tank inspection, repair, and recordkeeping and recording requirements.

**Table 5.2 – Subpart Kb Tanks List**

Tank Name	Tank	Number of Tanks	Operating Temperature (°F)	Vapor Pressure At Operational Temperature (psia)	Liquid Capacity (Gallons)	Roof Type
Methanol Tanks	TBD	2	45	0.96	6,341,984	IFR
Gasoline Product Tanks	TBD	8	45	4.14	6,341,984	IFR
Heavy Gasoline Tank <sup>1</sup>	TBD	1	45	2.25	4,763,841	IFR

1. "Heavy" gasoline is estimated to have RVP of 3-5 psia.

**Subpart Y Coal Preparation Plant NSPS**

Under 40 CFR Part 60, Subpart Y, coal transfer, crushing, and drying activities are subject to particulate matter emission limits. Specifically, emissions from coal conveying equipment may not exceed 20 percent opacity. Use of fully covered conveyors and fogging of transfer points at the Plant should maintain compliance with Subpart Y particulate emission limits and opacity standards.

***Subpart VV Equipment Leaks in the SOCOMI Industry NSPS***

The Plant does not meet the definition of a facility that is part of the Synthetic Organic Chemical Manufacturing Industry (SOCMI). Consequently, the Plant is not subject to this regulation.

***Subpart IIII Stationary Compression Ignition Internal Combustion Engine NSPS***

The diesel Firewater Pump will be subject to the compression ignition (diesel) engine NSPS. Compliance with this regulation is relatively simple for engine owners who purchase an engine that is certified by the engine manufacturer to meet new engine standards. MBFP will likely purchase a 2008 or later model year engine and will comply with this rule.

***Subpart KKKK Stationary Combustion Turbines NSPS***

The combustion turbines will be subject to NSPS codified in 40 CFR Part 60, Subpart KKKK. Affected units will include the three combustion turbines because they each have a heat input at peak load of more than 10 MMBtu/hr and will commence construction after February 18, 2005 [§60.4305(a)].

The combustion turbines will burn a mixture of fuel gas, LPG, and natural gas. Since more than 50 percent of the mixture will be natural gas, the turbines will be deemed to be firing natural gas [§60.4325]. Therefore, the NO<sub>x</sub> emission limit will be based on a new turbine with a heat input of between 50 and 850 MMBtu/hr firing natural gas fuel. The applicable NO<sub>x</sub> limit is 25 ppm (corrected to 15 percent oxygen) or 1.2 lb/MWh [40 CFR Part 60, Subpart KKKK, Table 1]. The turbines can meet the SO<sub>2</sub> compliance requirements by burning fuels with potential emissions of less than 0.060 lb SO<sub>2</sub>/MMBtu [§60.4330(a)(2)]. Extensive monitoring, recordkeeping, and reporting are required by the rule. Because the combustion turbines will be subject to this recent NSPS, they will not be subject to CAM requirements.

**5.2.2 National Emissions Standards for Hazardous Air Pollutants (NESHAP)**

The Plant will be a major source of HAPs. Consequently, it may be subject to a variety of NESHAP regulations. The following discussion identifies NESHAPs that are potentially applicable to the facility.

***Subpart ZZZZ Reciprocating Internal Combustion Engine NESHAP***

Subpart ZZZZ within 40 CFR Part 63, will apply to all reciprocating internal combustion engines (RICE) at the Plant that have a site rating of more than 500 brake horsepower. The three Black-Start Generators, each nominally rated at 2,889 horsepower, will be subject to rule. However, many of the compliance requirements within Subpart ZZZZ may not apply to these units, depending on their use. They may qualify as "emergency use RICE" or as "limited use RICE," especially if they are used less than the amount of time assumed for emission estimation purposes in this permit application (250 hr/yr, each).

***Subpart DDDDD Industrial-Commercial-Institutional Steam Generating Unit NESHAP***

The Industrial-Commercial-Institutional Steam Generating NESHAP has been vacated and future compliance requirements are uncertain until USEPA promulgates a new rule. When a new or revised rule becomes effective, the Auxiliary Boiler and most or all of the process heaters may be subject this NESHAP.

**5.2.3 Chemical Accident Prevention Provisions**

The Chemical Accident Prevention Provisions in 40 CFR Part 68 set forth requirements concerning the prevention of accidental releases. All facilities with extremely hazardous substances have a "general duty" to prevent accidental releases. Consequently, the Plant must design and maintain a safe facility, including taking steps to prevent releases and minimizing the consequences of any releases that do occur.

In addition, a facility that has more than a threshold quantity of a regulated substance listed in §68.130 may be subject to a variety of compliance requirements in Part 68. Guidance on how to determine if a threshold quantity exists and exceptions for certain types of facilities, processes, and materials are provided in §68.115. For example, regulated substances in gasoline need not be considered when determining if a threshold quantity exists in a process. Thus, the gasoline in the MTG process and product storage tanks will not be included in the applicability determination. The proposed methanol tanks also will not be considered in the applicability determination because methanol is not on the list of regulated sources.

With the exception of H<sub>2</sub>S, the proposed facility will not store or use any ammonia, chlorine, methyl mercaptan, or other chemicals included as "toxic substances" in §68.130. However, several processes will contain a mixture of H<sub>2</sub>S and/or substances listed as "flammable substances" at §68.130 (methane, ethane, propane, etc.) with concentrations high enough to possibly qualify the entire process stream, per §68.115(b)(1) and (2). As a result, this regulation may apply to some processes at the Plant if the process in question (as defined at §68.3) contains more than a threshold quantity of the listed substance. Prior to beginning operation, MBFP will determine whether it is subject to Part 68 regulations and, if necessary, prepare a Risk Management Plan for the Plant.

**6.1 BACKGROUND**

*NOTE: The near field modeling analysis presented in this section and the far field modeling analysis presented in Section Seven are based on emissions and process parameters described in the original Permit Application dated June 19, 2007. This analysis is presented in its entirety to comprehensively describe the modeling conducted for the June 2007 permit application. The near field modeling analysis was supplemented on October 17, 2007 in response to comments from the WDEQ. These responses are included in Appendix J.*

*MBFP believes that this near field criteria pollutant modeling analysis should be considered to be sufficient with regard to criteria pollutants emitted by the proposed facility based on the revised process design. A comparison of revised emission rates and previously modeled emission rates is presented in Appendix I. Due to a substantial increase in HAP emissions, a new near field risk-based HAP impact analysis based on emissions presented in Section Three and in Appendix B and is presented in Appendix H.*

As detailed in prior sections of this application, the proposed Plant will potentially emit regulated air pollutants in excess of permitting thresholds. In accordance with Wyoming regulations, the pollutants potentially exceeding threshold levels are subject to permit requirements, including the assessment of the likely impact to air quality.

To assess likely impacts, a dispersion modeling analysis was completed for areas within 10 km (near field) of the proposed facility. The analysis was completed in accordance with a protocol approved by WAQD (05 March 2007). The air quality dispersion modeling analysis used the EPA-approved AERMOD suite of programs including AERMOD (version 07026), AERMAP (version 06341) and AERMET (version 06341).

The analysis included:

- 1 Determination of emission inventory source characteristics;
- 2 Development of an appropriate receptor grid, beginning at the ambient air boundary, with digital elevation model (DEM) supplied terrain heights calculated using AERMAP;
- 3 Determination of applicable direction-specific downwash parameters using the Building Profile Input Program (bpip) PRIME (bpipprm) for the many tanks and other structures associated with the project sources;
- 4 Processing of local and representative surface and upper air meteorological data to form a five-year model ready data set in AERMET;
- 5 Modeling of Medicine Bow project emissions in AERMOD and comparison with threshold levels; and
- 6 Modeling of project and associated coal mining feedstock operations for comparison with ambient air quality levels.

Details of these steps are provided in following subsections.



**6.2 DESCRIPTION OF PROPOSED PROJECT****6.2.1 Site Location**

The facility will be located approximately 7.5 miles north of Interstate 80, exit 260 (Elk Mountain) on County Road #3 in Section 29 of Township 21 north and Range 79 west in Carbon County, Wyoming as shown in Figure 1.1. The UTM coordinate (NAD27) of the center of Section 29 is 390634 meters E and 4624013 meters N. A topographic map of the facility area indicating Section 29 is shown in Figure 1.1. Photographs of the proposed site area are shown in Figure 6.1 and Figure 6.2, depicting the varying terrain.

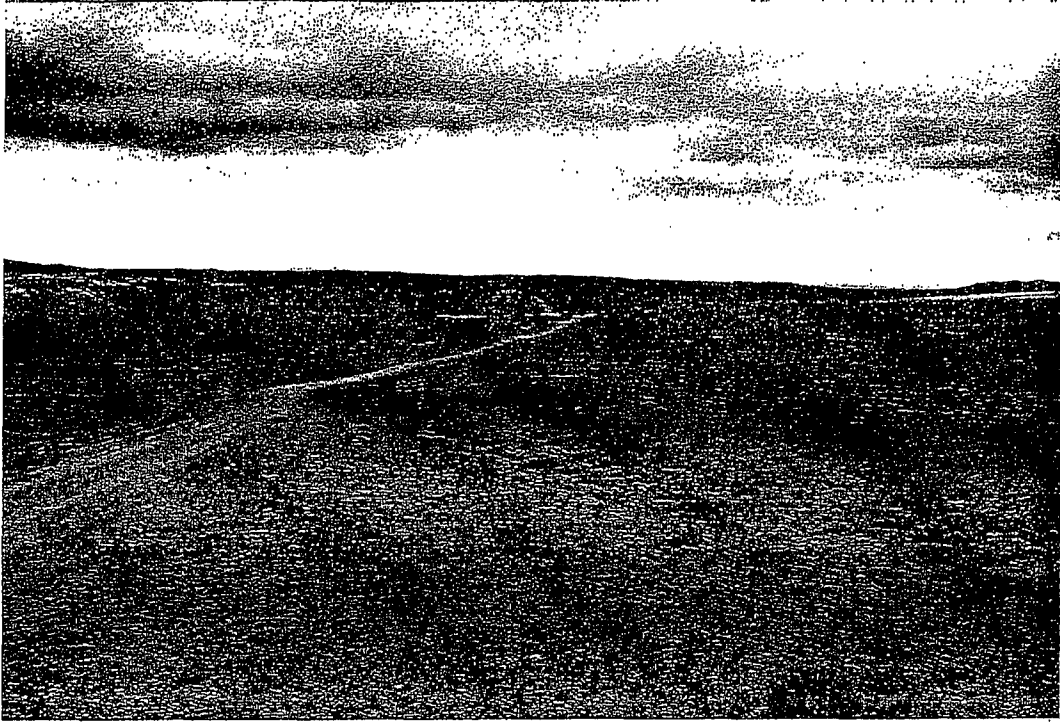
Within this area the facility will be constructed and will include:

- 1 Three (3) GE frame 7 gas combustion turbines;
- 2 Coal pre-treatment block;
- 3 Air separation block;
- 4 Fischer-Tropsch block;
- 5 Power block;
- 6 Product storage block;

As the proposed project is classified a 'Fuel Conversion Plant', which is one of the 28 major stationary sources, the project is subject to review under the Prevention of Significant Deterioration (PSD) guidelines with a threshold of 100 tons per year for all criteria pollutants. And as shown in prior sections, the estimated emissions from the facility exceed these levels for some regulated air pollutants, and therefore, the project is subject to PSD review.

The project site is located in an area that is designated as attainment of all National Ambient Air Quality Standards (NAAQS).

**Figure 6.1 – Medicine Bow Project Site Area, View from South Side**



**Figure 6.2 – Medicine Bow Project Site Area, View Over Coal Hills Toward Elk Mountain**

### 6.2.2 Source Emissions and Parameters

The Medicine Bow operations and emissions resulting from those planned activities have been described above. The modeled emission rates were based on the activity levels and any applied control techniques so that a reasonably conservative emission estimate was used. Where practicable, combinations of operations were developed to allow operational flexibility for future Medicine Bow activities. For example, cold and warm startup scenarios were examined in combination with likely normal operations to determine both likely annual as well as potentially combined short-term operating parameters and emissions.

This combination of activities resulted in the annual emission estimates of the five regulated pollutants as shown in Table 6.1.

**Table 6.1 – Annual Modeled Emission Levels**

Pollutant	NO <sub>x</sub>	CO	VOC	SO <sub>2</sub>	PM <sub>10</sub>
Total Annual Emissions (ton/year)	617	1044	125	201	308

Note: These emissions are based on the June 19, 2007 original permit application.

Of the emitted pollutants shown in Table 6.1, VOC is not explicitly modeled, but because it has the potential to be emitted in excess of 100 ton/year the possibility of ozone production needs to be addressed. However, given the relatively low amount of VOC emissions and the location of the source and surrounding area, there is little potential for adverse ozone formation resulting

from the emissions of VOC from the Medicine Bow project emission units. Therefore no VOC analysis is required.

The other four regulated pollutants were explicitly modeled and the model input parameters are shown in Table 6.2.

The input parameters are based on vendor information or established emission factor of similar unit operations and reflect maximum modeled emission rate combinations from the various operating scenarios (cold start-up, warm start-up, normal) and temperature sensitive emission units. Pollutants with short-term averaging periods (CO, SO<sub>2</sub>, PM<sub>10</sub>) were modeled at maximum short-term rates from all operating scenarios, whereas the annual pollutant emissions of NO<sub>x</sub> were based on additive operations across all the scenarios (7260 hours/year of normal operations +1,000 hours/year of cold start-up conditions + 500 hours/year of warm start-up conditions).

**Table 6.2 – Modeled Project Source Parameters**

Emission Unit	Model ID	Type	Location UTM			Modeled Exhaust Parameters				Modeled Emission Rates (g/s)			
			X (m)	Y (m)	Z (m msl)	Height (m)	Temp (K)	Velocity (m/s)	Diameter (m)	NO <sub>x</sub>	CO	SO <sub>2</sub>	PM <sub>10</sub>
Turbine and HRSG Train 1	CTG1	Point	391370.9	4623838.5	2115.0	45.73	355.40	11.50	5.79	3.96E+00	1.01E+01	5.62E-03	1.26E+00
Turbine and HRSG Train 2	CTG2	Point	391369.2	4623777.2	2115.2	45.73	355.40	11.50	5.79	3.96E+00	1.01E+01	5.62E-03	1.26E+00
Turbine and HRSG Train 3	CTG3	Point	391367.5	4623716.3	2114.0	45.73	355.40	11.50	5.79	3.96E+00	1.01E+01	5.62E-03	1.26E+00
Gasifier Preheater 1	GHEAT1	Point	391050.6	4623693.4	2117.3	25.91	422.05	7.45	0.41	5.29E-03	1.56E-01	1.11E-03	1.41E-02
Gasifier Preheater 2	GHEAT2	Point	391050.2	4623681.2	2116.4	25.91	422.05	7.45	0.41	5.29E-03	1.56E-01	1.11E-03	1.41E-02
Gasifier Preheater 3	GHEAT3	Point	391049.9	4623669.0	2115.6	25.91	422.05	7.45	0.41	5.29E-03	1.56E-01	1.11E-03	1.41E-02
Gasifier Preheater 4	GHEAT4	Point	391049.6	4623656.8	2114.9	25.91	422.05	7.45	0.41	5.29E-03	1.56E-01	1.11E-03	1.41E-02
Gasifier Preheater 5	GHEAT5	Point	391049.2	4623644.6	2114.5	25.91	422.05	7.45	0.41	5.29E-03	1.56E-01	1.11E-03	1.41E-02
H-3102 SRU Incinerator	H3102	Point	391137.2	4624096.2	2121.7	45.73	422.05	0.13	4.57	2.64E-02	2.49E-02	1.20E+00	2.57E-01
H-5401 Frac Feed Heater	H5401	Point	391299.1	4624173.2	2117.4	45.73	422.05	4.79	1.22	2.71E-01	9.03E-01	3.22E-03	4.08E-02
Turbine and HRSG Train 1	CTG1	Point	391370.9	4623838.5	2115.0	45.73	355.40	11.50	5.79	3.96E+00	1.01E+01	5.62E-03	1.26E+00
Turbine and HRSG Train 2	CTG2	Point	391369.2	4623777.2	2115.2	45.73	355.40	11.50	5.79	3.96E+00	1.01E+01	5.62E-03	1.26E+00
Turbine and HRSG Train 3	CTG3	Point	391367.5	4623716.3	2114.0	45.73	355.40	11.50	5.79	3.96E+00	1.01E+01	5.62E-03	1.26E+00
Gasifier Preheater 1	GHEAT1	Point	391050.6	4623693.4	2117.3	25.91	422.05	7.45	0.41	5.29E-03	1.56E-01	1.11E-03	1.41E-02
Gasifier Preheater 2	GHEAT2	Point	391050.2	4623681.2	2116.4	25.91	422.05	7.45	0.41	5.29E-03	1.56E-01	1.11E-03	1.41E-02
Gasifier Preheater 3	GHEAT3	Point	391049.9	4623669.0	2115.6	25.91	422.05	7.45	0.41	5.29E-03	1.56E-01	1.11E-03	1.41E-02

**Table 6.2 – Modeled Project Source Parameters**

Emission Unit	Model ID	Type	Location UTM			Modeled Exhaust Parameters				Modeled Emission Rates (g/s)			
			X (m)	Y (m)	Z (m.msl)	Height (m)	Temp (K)	Velocity (m/s)	Diameter (m)	NO <sub>x</sub>	CO	SO <sub>2</sub>	PM <sub>10</sub>
Gasifier Preheater 4	GHEAT4	Point	391049.6	4623656.8	2114.9	25.91	422.05	7.45	0.41	5.29E-03	1.56E-01	1.11E-03	1.41E-02
Gasifier Preheater 5	GHEAT5	Point	391049.2	4623644.6	2114.5	25.91	422.05	7.45	0.41	5.29E-03	1.56E-01	1.11E-03	1.41E-02
H-3102 SRU Incinerator	H3102	Point	391137.2	4624096.2	2121.7	45.73	422.05	0.13	4.57	2.64E-02	2.49E-02	1.20E+00	2.57E-01
H-5401 Frac Feed Heater	H5401	Point	391299.1	4624173.2	2117.4	45.73	422.05	4.79	1.22	2.71E-01	9.03E-01	3.22E-03	4.08E-02
H-5301 Cat Dewax Charge	H5301	Point	391267.3	4624165.0	2120.0	15.24	422.05	1.93	0.41	1.22E-02	4.05E-02	1.36E-04	3.05E-02
H-5201 Unicracker Feed	H5201	Point	391266.5	4624047.0	2118.6	15.24	422.05	1.60	0.91	5.09E-02	1.69E-01	5.68E-04	1.28E-01
H-5202 Unicracker Intermed.	H5202	Point	391270.0	4624083.5	2117.2	30.49	422.05	3.19	1.07	1.38E-01	4.59E-01	1.54E-03	3.47E-01
H-5101 Unionfiner Feed	H5101	Point	391295.0	4624046.2	2116.8	15.24	422.05	2.03	0.51	1.60E-02	5.30E-02	1.78E-04	4.01E-02
H-5102 Unionfiner Intermed	H5102	Point	391292.8	4624113.3	2115.1	15.24	422.05	2.54	0.41	1.99E-02	6.61E-02	2.22E-04	5.00E-02
Black-Start Generator 1	BSG1	Point	391303.6	4623910.9	2117.2	6.10	767.60	1.96	0.41	2.29E-02	1.95E+00	1.44E-03	1.89E-04
Black-Start Generator 2	BSG2	Point	391303.8	4623901.8	2117.5	6.10	767.60	1.96	0.41	2.29E-02	1.95E+00	1.44E-03	1.89E-04
Black-Start Generator 3	BSG3	Point	391303.5	4623892.6	2117.6	6.10	767.60	1.96	0.41	2.29E-02	1.95E+00	1.44E-03	1.89E-04
Firewater Pump	FIREPUMP	Point	391286.3	4623564.2	2104.0	6.10	739.27	45.00	0.15	4.33E-02	4.63E-02	7.64E-04	9.58E-03

Note: These emissions are based on the June 19, 2007 original permit application.

**6.3 STANDARDS AND CRITERIA LEVELS**

The results of the air quality dispersion modeling analysis are compared with various ambient levels to assess the potential impacts to local air quality resulting from the project. Because the MBFP project is subject to PSD review, PSD source emissions must not cause an exceedance of any ambient air quality standards, and the increase in ambient air concentrations must not exceed the allowable increments shown in Table 6.3.

**Table 6.3 – PSD Class II Increments**

Pollutant	Averaging Period	Allowable Increment ( $\mu\text{g}/\text{m}^3$ )
Nitrogen Dioxide	Annual	25
Sulfur Dioxide	3-hour	512
	24-hour	91
	Annual	20
Particulate Matter <10 $\mu\text{m}$ [PM <sub>10</sub> ]	24-hour	30
	Annual	17

The dispersion modeling analysis typically involves a two-step approach. The initial phase only looks at the proposed source and is referred to as the significant impact analysis (SIA). It simply determines whether the applicant can do without further air quality modeling for a particular pollutant with respect to the NAAQS and PSD increments.

The next phase includes a more robust analysis and must include the proposed sources as well as nearby sources and take into account the background air quality concentration for the particular pollutant and averaging time. If the applicant has a pollutant-specific significant impact, then further analysis for that pollutant may be required to compare predicted aggregate air quality impacts against applicable NAAQS, and/or PSD increments.

In the initial SIA analysis the highest predicted off-site concentration for each pollutant and each averaging period is compared to the modeling significance levels in Table 6.4. Neither nearby sources nor background ambient air quality concentrations are considered in this analysis. If the estimated concentration levels are below the applicable modeling significance level, no further analysis is required and the source is considered to have an insignificant impact.

**Table 6.4 – Significant Impact Levels (SILs)**

Pollutant	Averaging Period	SIL ( $\mu\text{g}/\text{m}^3$ )
Nitrogen Dioxide	Annual	1
Sulfur Dioxide	3-hour	25
	24-hour	5
	Annual	1

Table 6.4 – Significant Impact Levels (SILs)

Pollutant	Averaging Period	SIL ( $\mu\text{g}/\text{m}^3$ )
Particulate Matter <10 $\mu\text{m}$ [ $\text{PM}_{10}$ ]	24-hour	5
	Annual	1
Carbon Monoxide	1-hour	2,000
	8-hour	500

## 6.4 NEAR-FIELD MODELING METHOD

### 6.4.1 Near-Field Modeling

The impact analysis requirements are applicable to the Medicine Bow project sources for the emissions of  $\text{NO}_x$ , CO,  $\text{SO}_2$  and  $\text{PM}_{10}$ . The impact analysis is designed to protect the National Ambient Air Quality Standards (NAAQS) and PSD increments. The NAAQS are maximum concentration “ceilings” measured in terms of the total concentration of a pollutant in the atmosphere. For a new source, compliance with any NAAQS is based upon the total estimated air quality, which is the sum of the background concentrations and the estimated ambient impacts of Medicine Bow’s proposed emissions. A PSD increment, on the other hand, is the maximum increase in ambient concentration that is allowed to occur above a baseline concentration for a pollutant. Significant deterioration is said to occur when the amount of new pollution would exceed the applicable PSD increment.

A detailed description of the modeling approach and data requirements for the assessment of air quality impacts due to the proposed project is included in this section.

### 6.4.2 Model Selection and Setup

The air quality impacts were modeled at near-field receptors using the latest version of the EPA regulatory model (AERMOD) (Version 07026). The AERMOD model is designed to predict ground-level pollutant concentrations from a wide variety of sources associated with industrial facility source types. AERMOD contains algorithms for: (1) dispersion in both the convective and stable boundary layers; (2) plume rise and buoyancy; (3) plume penetration into elevated inversions; (4) computation of vertical profiles of wind, turbulence, and temperature; (5) urban nighttime boundary layer; (6) treatment of receptors on all types of terrain from the surface up to and above the plume height; (7) treatment of building wake effects; (8) improved approaches for characterizing the fundamental boundary layer parameters, and (9) treatment of plume meander.

The AERMOD modeling system consists of two pre-processors; AERMET which provides AERMOD with the meteorological information it needs to characterize the planetary boundary layer (PBL), and AERMAP, which characterizes the terrain, and generates receptor grids for AERMOD.

Pursuant to Wyoming Department of Environmental Quality (WDEQ) modeling guidelines (2006a and 2006b), the regulatory default options were used, including building and stack tip



downwash, default wind speed profiles, exclusion of deposition and gravitational settling, consideration of buoyant plume rise and complex terrain.

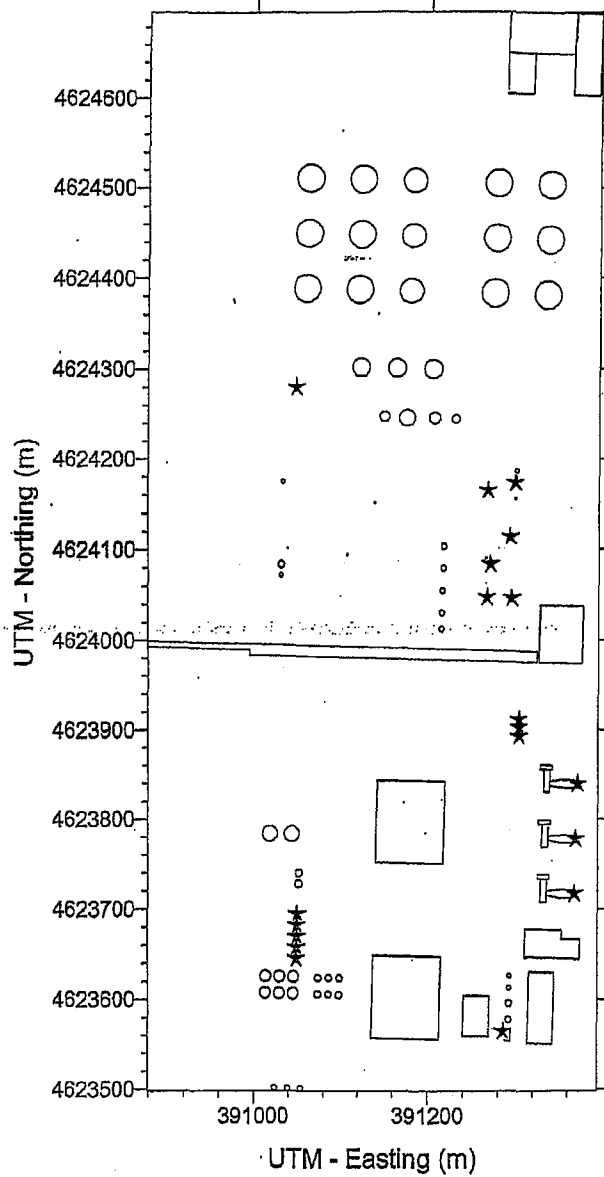
Emission sources at Medicine Bow will be influenced by aerodynamic downwash. Since downwash is a function of projected building width and height, it is necessary to account for the changes in building projection as they relate to changes in wind direction. Once these projected dimensions are determined, they can be used as input to the AERMOD model.

The USEPA Building Profile Input Program (BPIP version 04274), enhanced to include the PRIME algorithms as applicable to AERMOD, was used to conduct the good engineering practice (GEP) stack height analysis and to determine wind direction-specific building/structure dimensions.

The BPIP-PRIME program builds a mathematical representation of each building or structure to determine projected building dimensions and its potential zone of influence. These calculations are performed for 36 different wind directions (at 10-degree intervals). If the BPIP-PRIME program determines that a source is under the influence of several potential building wakes, the structure or combination of structures which has the greatest influence ( $h_b + 1.5 l_b$ ) is selected for input to the model.

Conversely, if no building wake effects are predicted to occur for a source for a particular wind direction, or if the worst-case building dimensions for that direction yield a wake region height less than the source's physical stack height, building parameters are set equal to zero for that wind direction. For this case, wake effect algorithms are not exercised when the model is run. The building wake criteria influence zone is  $5 l_b$  downwind,  $2 l_b$  upwind, and  $0.5 l_b$  crosswind. These criteria are based on recommendations by USEPA. The PRIME algorithm addresses the entire structure of the wake, from the cavity immediately downwind of the building, to the far wake. The input to the bpip program consisted of the location of the Medicine Bow emission units and the coordinates and heights of the buildings and structures. The structures used in the analysis are shown in Figure 6.3 along with the source locations.

**Figure 6.3 – Good Engineering Practice (GEP) Stack Height Assessment, Building and Source Location Depiction**



**6.4.3 Data Bases for Air Quality Assessment**

The databases required for the air quality impact assessment included meteorological data, receptor points and terrain data. The following sections describe the databases required to perform the air quality impact assessment.

#### 6.4.4 Meteorological Data

Nearby sources of meteorological data (two surface sites and one upper air site) were identified, and six years of recent (2000 - 2005) meteorological data were obtained, reviewed for completeness, and the valid years were processed in AERMET. The surface sites included a nearby meteorological tower installation with automatic recording instrumentation located outside of Elmo, WY, about 24 km northwest of the Medicine Bow site, and a National Weather Service (NWS) ASOS site located at the Rawlins Municipal Airport approximately 70 km west of the Medicine Bow location.

Inter-Mountain Labs (IML) operated the meteorological station in accordance with *Meteorological Monitoring Guidance for Regulatory Modeling Applications* (EPA-454/R-99-005). IML performed semi-annual quality assurance audits on the station and the IML staff conducted quality control procedures on the data. IML submitted quarterly reports (including semiannual quality assurance audits) to Dennis Wuertz at Seminoe (Arch of Wyoming, LLC), who then submitted the reports to Bob Schick at the Wyoming Division of Air Quality. Cara Keslar in the Air Quality Monitoring Division may be contacted with regard to this data.

In order to meet the completeness criteria for PSD-quality meteorological data, only 10 percent of the data in any given year can be missing. As described below, data for the 2002 year recorded from the preferred site of Elmo was incomplete and more than 10 percent was missing. Therefore a five year meteorological data set was developed for the years 2000-2001, and 2003-2005 with the Elmo site noted as the "on-site" location and the Rawlins site as the NWS surface location. This five year data set was processed in AERMET to a model ready format. A description of the data and the completeness assessment follows.

Six years of hourly surface observations (2000 through 2005) from the Rawlins Municipal Airport, WY were obtained from the National Climatic Data Center (NCDC) in AERMET compatible TD3505 format. The Rawlins NWS site is located approximately 70km west of the proposed facility at UTM coordinates (NAD27) 317221 meters E and 4629697 meters N.

Therefore, the Rawlins hourly surface met data were reviewed to establish completeness. The result of the review of the Rawlins data is shown in Table 6.5. The normalized frequency distribution of wind speed and direction for the Rawlins data is shown in Table 6.6.

During the review of the data it was determined that data obtained during 2002 was not satisfactory for use, and therefore, while complete at the Rawlins site, 2002 data will not be used and therefore is not shown in Table 6.5. As shown in Table 6.5, the collected Rawlins data satisfied the PSD completeness requirement.

Table 6.5 – Data Completeness Evaluation, Rawlins NWS Hourly Surface Meteorological Data

Year	Number of Missing Hours	Percent Complete (%)
2000	130	98.5
2001	504	94.2
2003	567	93.5
2004	447	94.9
2005	514	94.1

Table 6.6 – Normalized Frequency Distribution of Wind Speed and Direction of Rawlins Hourly Surface Meteorological Data (2000, 2001, 2003, 2004, and 2005)

Wind Direction	Wind Speed						Total
	0.5 - 2.1	2.1 - 3.6	3.6 - 5.7	5.7 - 8.8	8.8 - 11.1	>= 11.1	
348.75 - 11.25	0.00837	0.01295	0.01408	0.00823	0.00148	0.00064	0.04575
11.25 - 33.75	0.00394	0.00494	0.00578	0.00321	0.00104	0.00055	0.01946
33.75 - 56.25	0.00367	0.00819	0.01237	0.00989	0.00356	0.00066	0.03836
56.25 - 78.75	0.00394	0.01056	0.01534	0.01082	0.00398	0.00122	0.04586
78.75 - 101.25	0.00591	0.00896	0.00600	0.00308	0.00082	0.00038	0.02514
101.25 - 123.75	0.00471	0.00436	0.00184	0.00042	0.00009	0.00000	0.01142
123.75 - 146.25	0.00370	0.00359	0.00166	0.00058	0.00011	0.00004	0.00967
146.25 - 168.75	0.00348	0.00301	0.00201	0.00086	0.00029	0.00009	0.00974
168.75 - 191.25	0.00527	0.00569	0.00465	0.00330	0.00162	0.00091	0.02143
191.25 - 213.75	0.00343	0.00730	0.00974	0.01138	0.00755	0.00441	0.04380
213.75 - 236.25	0.00509	0.01439	0.02545	0.02579	0.02039	0.01576	0.10686
236.25 - 258.75	0.00494	0.01968	0.05686	0.07689	0.04447	0.02811	0.23094
258.75 - 281.25	0.00691	0.01753	0.03776	0.05584	0.03723	0.02663	0.18190
281.25 - 303.75	0.00421	0.00737	0.01158	0.01009	0.00425	0.00248	0.03997
303.75 - 326.25	0.00438	0.00790	0.00852	0.00460	0.00097	0.00027	0.02665
326.25 - 348.75	0.00487	0.00892	0.00779	0.00374	0.00069	0.00013	0.02614
Sub-Total:	0.07680	0.14533	0.22143	0.22873	0.12853	0.08227	0.81882
Calms:							0.12856
Missing/Incomplete:							0.05262
Total:							1.00000

Upper air data are needed to estimate hourly mixing heights, which are required inputs to the AERMOD dispersion model. The most suitable NWS station to the project site that routinely

performs upper air soundings is the NWS station in Riverton, WY (WBAN 24061), which is located approximately 250 km northwest of the proposed project site. The UTM coordinates (NAD27) of the Riverton NWS station are 217421 meters E and 4773109 meters N. Twice-daily upper air sounding data was obtained from the National Oceanic & Atmospheric Administration (NOAA), <http://raob.fsl.noaa.gov/>.

So that the upper air data coincided with the surface data, and as discussed with WDEQ, the same five years (2000, 2001, 2003, 2004, and 2005) were used for both the NWS surface and upper air data in the AERMET processing.

Six years of nearby site-specific meteorological data, 2000 through 2005, have been collected from a meteorological monitoring station outside of Elmo, WY. This site is approximately 24 km northwest of the proposed source location. The UTM coordinates (Zone 13, NAD27) of this station are 372052 meters E, 4638122 meters N. Five parameters for each hour were collected including wind direction (degree), wind speed (meters per seconds), sigma theta (degrees), temperature (Celsius), and precipitation (millimeters). Sensor elevations are 10 meters above grade level (agl) for wind speed and direction, 2 meters (agl) for temperature, and approximately 1 meter (agl) for precipitation.

As with the NWS surface data, this nearby site-specific data was reviewed for completeness, with the result shown in Table 6.7. Normalized frequency distributions of wind speed and direction are shown in Table 6.8.

As shown in Table 6.7, the collected 2002 nearby site-specific data do not satisfy the completeness criteria for 2002 as only 64%, 40%, and 81% of the data are available during the 2<sup>nd</sup>, 3<sup>rd</sup>, and 4<sup>th</sup> quarters of the year. Therefore, 2000, 2001, 2003, 2004, and 2005 on-site data were used for the AERMET processing and AERMOD modeling. The windrose of the processed AERMET data based primarily on the site-specific Elmo hourly surface meteorological data is shown in Figure 6.4.

Table 6.7 – Nearby Site-Specific Meteorological Data Completeness Capture

Months	Year	1st Quarter	2nd Quarter	3rd Quarter	4th Quarter
		January-March	April-June	July-September	October-December
Total Hours per Quarter		2184 or 2160	2184	2208	2208
Number of Missing Hours	2000	0	193	0	1
	2001	0	2	0	1
	2002	159	787	1316	420
	2003	0	1	1	2
	2004	2	0	1	50
	2005	2	50	1	0
Percent Completed (%)	2000	100.0	91.2	100.0	100.0
	2001	100.0	99.9	100.0	100.0
	2002	92.6	64.0	40.4	81.0
	2003	100.0	100.0	100.0	99.9
	2004	99.9	100.0	100.0	97.7
	2005	99.9	97.7	100.0	100.0

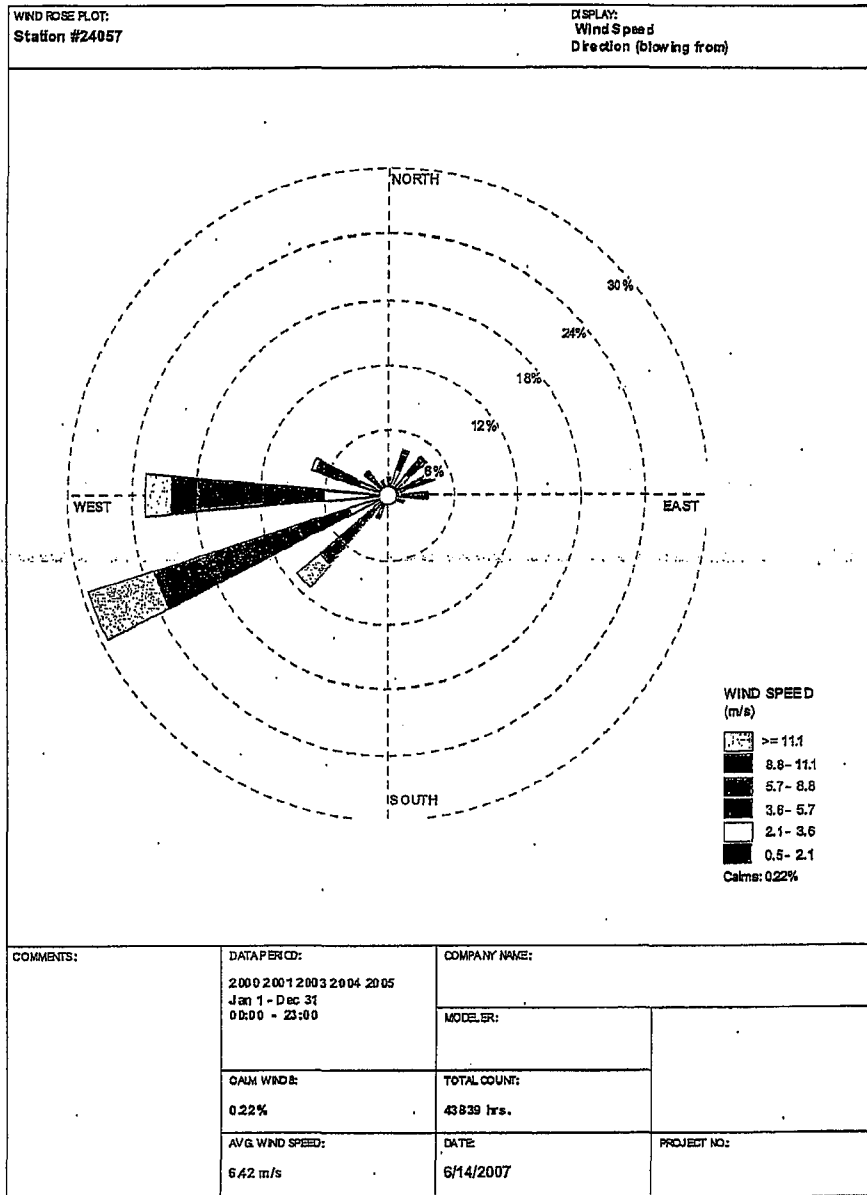
Table 6.8 – Normalized Frequency Distribution of Wind Speed and Direction of On-Site Meteorological Data (2000, 2001, 2003, 2004, and 2005)

Wind Direction	Wind Speed						Total
	0.5 - 2.1	2.1 - 3.6	3.6 - 5.7	5.7 - 8.8	8.8 - 11.1	>= 11.1	
348.75 - 11.25	0.004324	0.004735	0.003614	0.002471	0.000641	0.000435	0.016219
11.25 - 33.75	0.008075	0.016951	0.013451	0.005079	0.001212	0.000206	0.044975
33.75 - 56.25	0.009654	0.013909	0.01336	0.007069	0.001601	0.000046	0.045639
56.25 - 78.75	0.006657	0.007115	0.012033	0.014206	0.004118	0.001098	0.045227
78.75 - 101.25	0.005834	0.00549	0.008144	0.011438	0.004621	0.001739	0.037266
101.25 - 123.75	0.005056	0.002905	0.002173	0.002471	0.001075	0.000732	0.014412
123.75 - 146.25	0.004392	0.001899	0.001304	0.000824	0.000275	0.000069	0.008762
146.25 - 168.75	0.002494	0.001533	0.000801	0.000732	0.000046	0.000069	0.005673
168.75 - 191.25	0.003088	0.002288	0.001967	0.001167	0.000458	0.000183	0.009151
191.25 - 213.75	0.005239	0.003317	0.004049	0.005536	0.002951	0.00183	0.022922
213.75 - 236.25	0.008373	0.008487	0.014161	0.02887	0.022831	0.030037	0.112758
236.25 - 258.75	0.01384	0.022991	0.051449	0.088555	0.054515	0.063803	0.295152
258.75 - 281.25	0.017729	0.040995	0.057397	0.062133	0.026308	0.022144	0.226706
281.25 - 303.75	0.010066	0.015945	0.019399	0.017638	0.005422	0.003912	0.072381
303.75 - 326.25	0.004873	0.004026	0.008396	0.00716	0.002173	0.001167	0.027795

**Table 6.8 – Normalized Frequency Distribution of Wind Speed and Direction of On-Site Meteorological Data (2000, 2001, 2003, 2004, and 2005)**

Wind Direction	Wind Speed						Total
	0.5 - 2.1	2.1 - 3.6	3.6 - 5.7	5.7 - 8.8	8.8 - 11.1	>= 11.1	
326.25 - 348.75	0.003797	0.002997	0.003637	0.002036	0.000572	0.00016	0.0132
Sub-Total:	0.11349	0.155583	0.215336	0.257383	0.128818	0.127628	0.995165
Calms:							0.001756
Missing/Incomplete:							0.003079
Total:							1

**Figure 6.4 – Wind Rose, Five Year Period**





### 6.4.5 Receptor Grid

The receptor grid used in the modeling analysis was designed to identify the maximum air quality impact due to the proposed project. The receptor grid began at the ambient air boundary and extended outward 10 km into ambient air. The following receptor spacing was used:

- 1 50 m spacing along the Medicine Bow ambient air boundary;
- 2 100 m spacing from the boundary to 1 km;
- 3 500 m spacing from 1 km out from the proposed project to 5 km; and
- 4 1 km spacing from 5 km to 10 km from the proposed project.

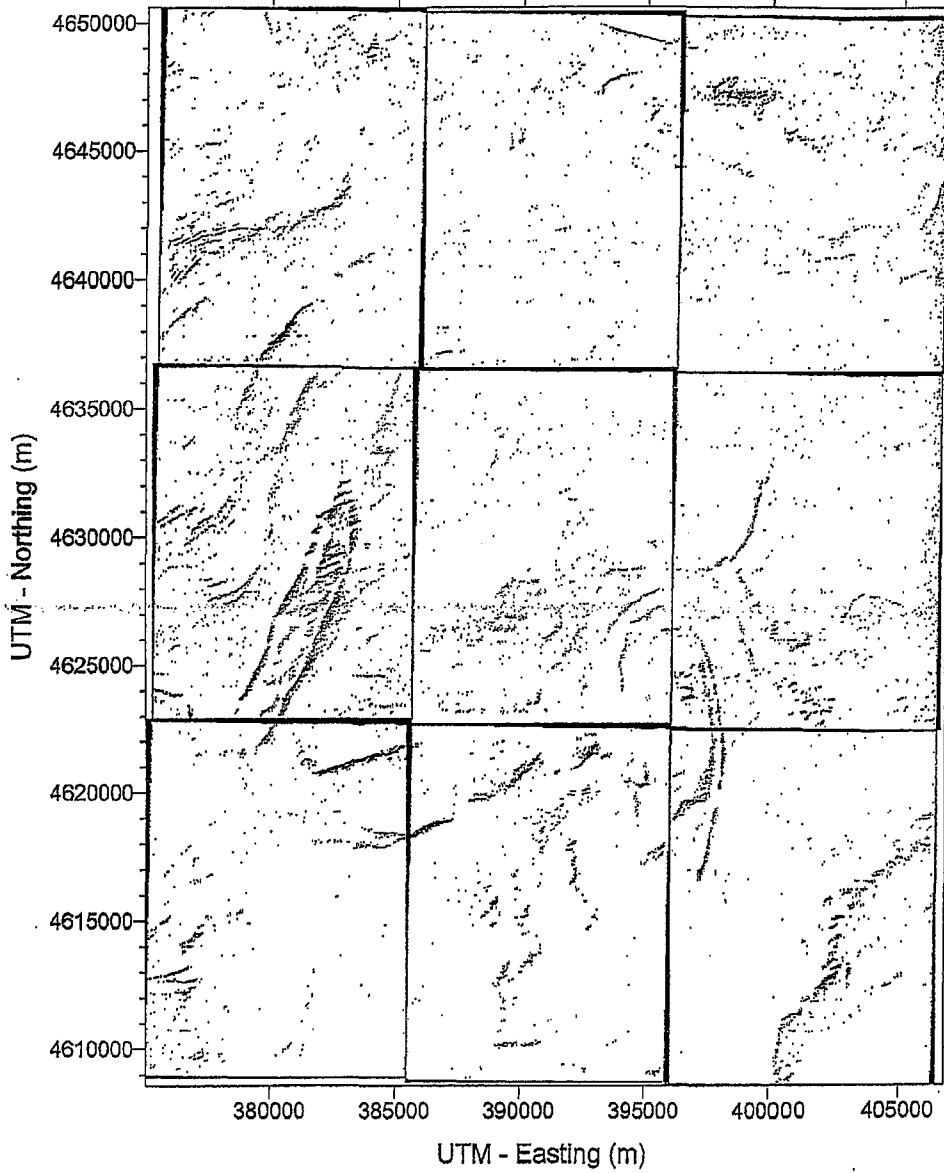
Receptor elevations were included for all receptor points and were obtained from digital elevation 7.5 minute topographic maps (<http://data.geocomm.com>). The surrounding terrain is depicted in shaded relief in Figure 6.5 and includes each of the nine 7.5 minute topo areas used in the AERMAP processing. Source elevations were also obtained from the same data using AERMAP. The receptor grid is shown in Figure 6.6 and again in Figure 6.7 atop the shaded relief.

## 6.5 GROWTH ANALYSIS

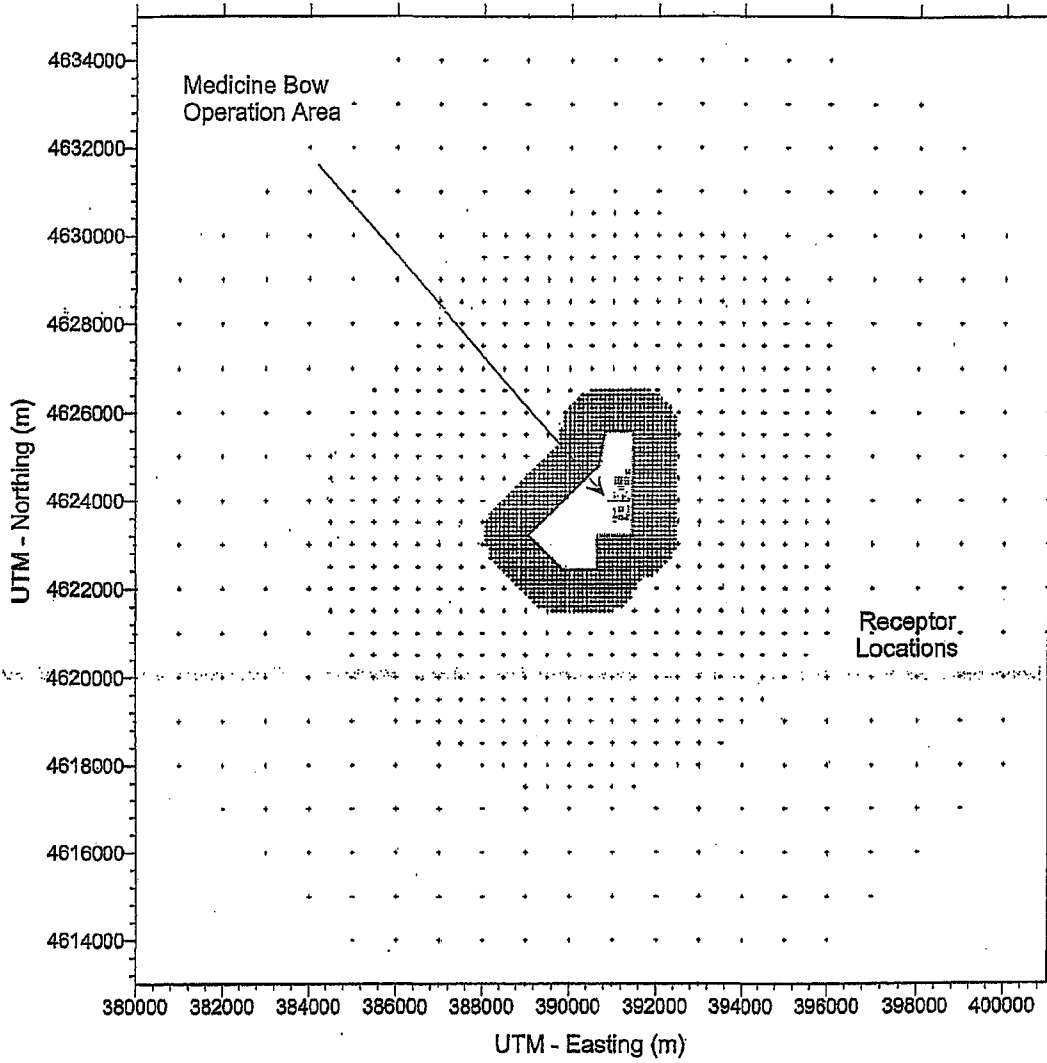
The MBFP project is expected to employ 300 to 400 people with various trades. Most of these trades are commonly found in the coal mining industry. These employees are expected to live in the existing communities of Elk Mountain, Medicine Bow, Hanna, and Saratoga. Carbon County has historically been a coal mining area with mining activity from the turn of the century through 2005. Population in the county has been declining since the 1990s (approximately 1,300) possibly resulting from the declining coal industry. The U.S. Census Bureau reports that there is more than adequate housing for these employees for new employees who want to move into the area.

The commercial support industries are already in place in Hanna and along the I-80 corridor. No new support industries are expected to move in the area.

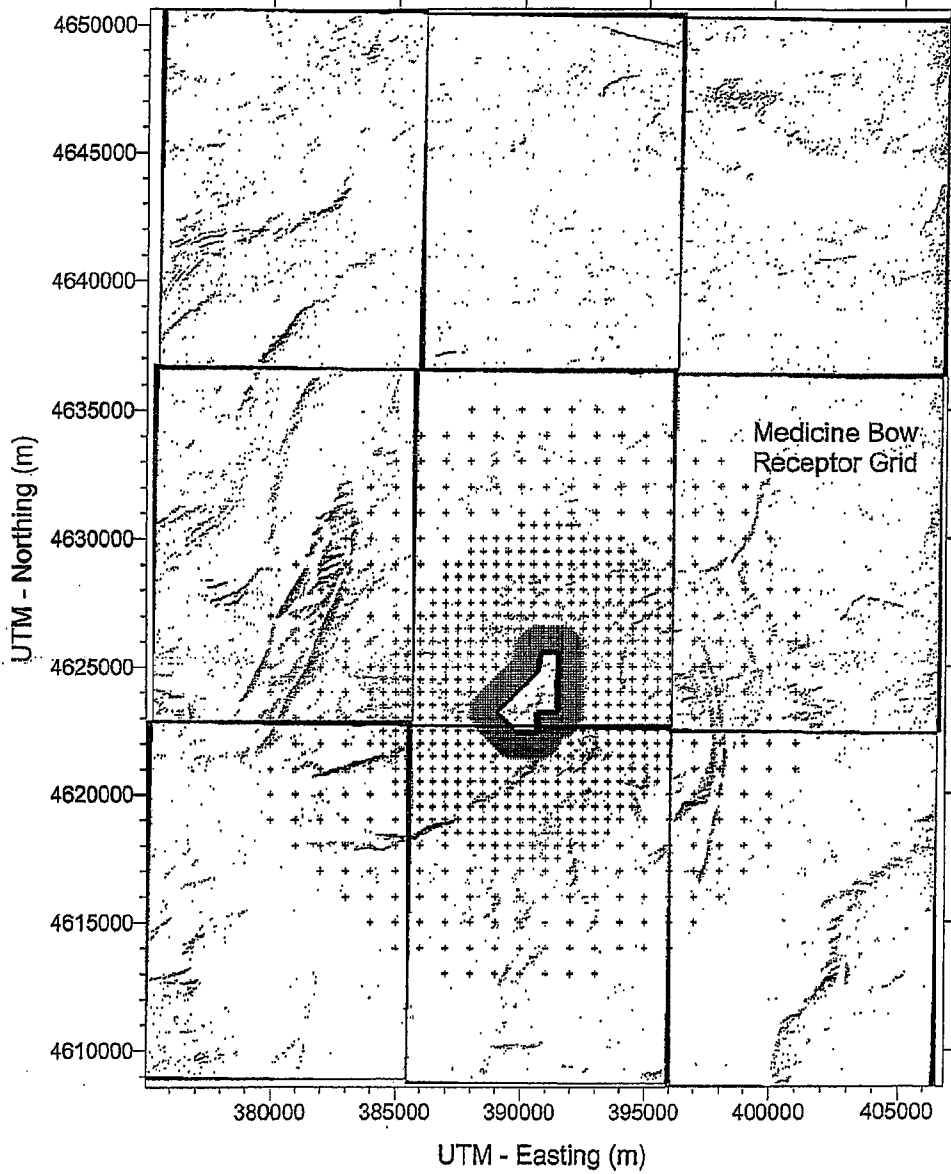
**Figure 6.5 – Surrounding Terrain as used in AERMAP**



**Figure 6.6 – Modeled Receptor Grid**



**Figure 6.7 – Medicine Bow – Receptor Grid Atop Shaded Relief Terrain Depiction**



**6.6 MODELING RESULTS**

Ambient air quality impact analyses for the MBFP project have been conducted to satisfy the Wyoming requirements for impacts from proposed sources. The following section describes the results of the ambient air quality impact analysis.

**6.6.1 SO<sub>2</sub> Modeling Demonstration**

Emissions of SO<sub>2</sub> from the proposed project were modeled using the representative databases described above. This analysis consisted of using the AERMOD dispersion model in conjunction with 5-years of hourly meteorological data. The purpose of this analysis was to determine whether the proposed project's emissions of SO<sub>2</sub> would have a significant impact on ambient air quality. If emissions of SO<sub>2</sub> result in maximum predicted annual, 24-hour and 3-hour concentrations exceeding the significant impact concentrations of 1.0 ug/m<sup>3</sup>, 5.0 ug/m<sup>3</sup> and 25.0 ug/m<sup>3</sup>, respectively, the proposed project will be considered to have a significant impact on air quality, requiring additional modeling analyses.

Table 6.9 presents the maximum predicted annual, 24-hour and 3-hour average concentrations for the proposed project.

**Table 6.9 – Medicine Bow - Maximum Predicted SO<sub>2</sub> Concentrations from the Proposed Project for Comparison with the SILs**

Averaging Period	Data Period			Receptor Location (M)		Maximum Predicted Concentration (Ug/M <sup>3</sup> )	SILs (Ug/M <sup>3</sup> )
	Year	Month/Day	Hour Ending	East	North		
Annual	2000	--	--	391800	4624400	0.71	1
	2001	--	--	391600	4624300	1.08	
	2003	--	--	391465	4624330	1.06	
	2004	--	--	391500	4624200	0.95	
	2005	--	--	391600	4624200	0.90	
24-Hour Highest	2000	09/28	24	392000	4622000	12.24	5
	2001	01/08	24	389700	4621700	11.25	
	2003	02/13	24	390400	4621800	11.34	
	2004	02/21	24	394500	4623500	8.79	
	2005	10/25	24	390300	4622000	11.47	
3-Hour Highest	2000	09/28	03	392000	4622000	72.9	25
	2001	01/08	21	389700	4621700	70.5	
	2003	02/28	06	390400	4621900	68.4	
	2004	02/11	24	392500	4622500	56.7	
	2005	12/07	06	394000	4624000	55.1	

**6.6.2 PM/PM<sub>10</sub> Modeling Demonstration**

Emissions of PM/PM<sub>10</sub> from the proposed project were modeled using the representative databases described above. This analysis consisted of using the AERMOD dispersion model in conjunction with 5-years of hourly meteorological data. The purpose of this analysis was to determine whether the proposed project's emissions of PM/PM<sub>10</sub> will cause a significant impact on ambient air quality. If emissions of PM/PM<sub>10</sub> result in maximum predicted annual and 24-hour concentrations exceeding the significant impact concentrations of 1.0 ug/m<sup>3</sup> and 5.0 ug/m<sup>3</sup>, respectively, then the proposed project will be considered to have a significant impact on air quality, requiring additional modeling analyses.

Table 6.10 presents the maximum predicted annual average and 24-hour concentrations for the proposed project.

**Table 6.10 – Maximum Predicted PM/PM<sub>10</sub> Concentrations from the Proposed Project for Comparison with the SILs**

Averaging Period	Data Period			Receptor Location (M)		Maximum Predicted Concentration (Ug/M <sup>3</sup> )	SILs (Ug/M <sup>3</sup> )
	Year	Month/Day	Hour Ending	East	North		
Annual	2000	--	--	391464	4624130	1.94	1
	2001	--	--	391464	4624130	2.16	
	2003	--	--	391500	4624200	2.22	
	2004	--	--	391500	4624100	1.84	
	2005	--	--	391500	4624100	1.91	
24-Hour Highest	2000	11/02	24	394500	4623500	6.0	5
	2001	02/26	24	390000	4621900	6.2	
	2003	03/20	24	391465	4624230	6.9	
	2004	06/30	24	391464	4624130	5.8	
	2005	02/24	24	394000	4623000	7.4	

**6.6.3 CO Modeling Demonstration**

Emissions of CO from the proposed project were modeled using the representative databases described above. This analysis consisted of using the AERMOD dispersion model in conjunction with 5-years of hourly meteorological data. The purpose of this analysis was to determine whether the proposed project's emissions of CO would have a significant impact on ambient air quality. If emissions of CO result in maximum predicted 8-hour and 1-hour concentrations exceeding the significant impact concentrations of 500 ug/m<sup>3</sup> and 2,000 ug/m<sup>3</sup>, respectively, the proposed project will be considered to have a significant impact on air quality, requiring additional modeling analyses.

Table 6.11 presents the maximum predicted 1-hour and 8-hour average concentrations for the proposed project.

**Table 6.11 – Maximum Predicted CO Concentrations from the Proposed Project for Comparison With the SILs**

Averaging Period	Data Period			Receptor Location (M)		Maximum Predicted Concentration (Ug/M <sup>3</sup> )	SILs (Ug/M <sup>3</sup> )
	Year	Month/Day	Hour	East	North		
			Ending				
1-Hour Highest	2000	11/22	02	391462	4623980	3770.9	2,000
	2001	11/04	04	391462	4623980	3734.7	
	2003	10/22	06	391462	4623980	3581.1	
	2004	07/11	03	391462	4623980	3435.0	
	2005	02/11	05	391462	4623980	4628.6	
8-Hour Highest	2000	01/02	08	391462	4623980	935.8	500
	2001	11/08	24	391462	4623980	1070.7	
	2003	06/08	08	391462	4623980	1344.3	
	2004	01/17	08	391462	4623980	898.6	
	2005	02/24	24	391463	4624030	1011.2	

**6.6.4 NO<sub>x</sub> Modeling Demonstration**

Emissions of NO<sub>x</sub> from the proposed project were modeled using the representative databases described above. This analysis consisted of using the AERMOD dispersion model in conjunction with 5-years of hourly meteorological data. The purpose of this analysis was to determine whether the proposed project’s emissions of NO<sub>x</sub> will have a significant impact on ambient air quality. If emissions of NO<sub>x</sub> result in maximum predicted annual concentrations exceeding the significant impact concentration of 1.0 ug/m<sup>3</sup>, the proposed project will be considered to have a significant impact on air quality, requiring additional modeling analyses.

Table 6.12 presents the maximum predicted annual average concentrations for the proposed project.

Table 6.12 – Maximum Predicted NO<sub>x</sub> Concentrations from the Proposed Project for Comparison with the SILs

Averaging Period	Data Period			Receptor Location (M)		Maximum Predicted Concentration (Ug/M <sup>3</sup> )	SILs (Ug/M <sup>3</sup> )
	Year	Month/Day	Hour	East	North		
			Ending				
Annual	2000	--	--	391462	4623980	3.11	1
	2001	--	--	391462	4623980	2.88	
	2003	--	--	391462	4623980	3.21	
	2004	--	--	391462	4623980	2.31	
	2005	--	--	391462	4623980	2.45	

### 6.6.5 Discussion of Results

The results shown in the above tables indicate that maximum aggregated emissions from the MBFP project sources have the potential to affect only local air quality. However, because the emissions are worst case, the likelihood of an impact is limited.

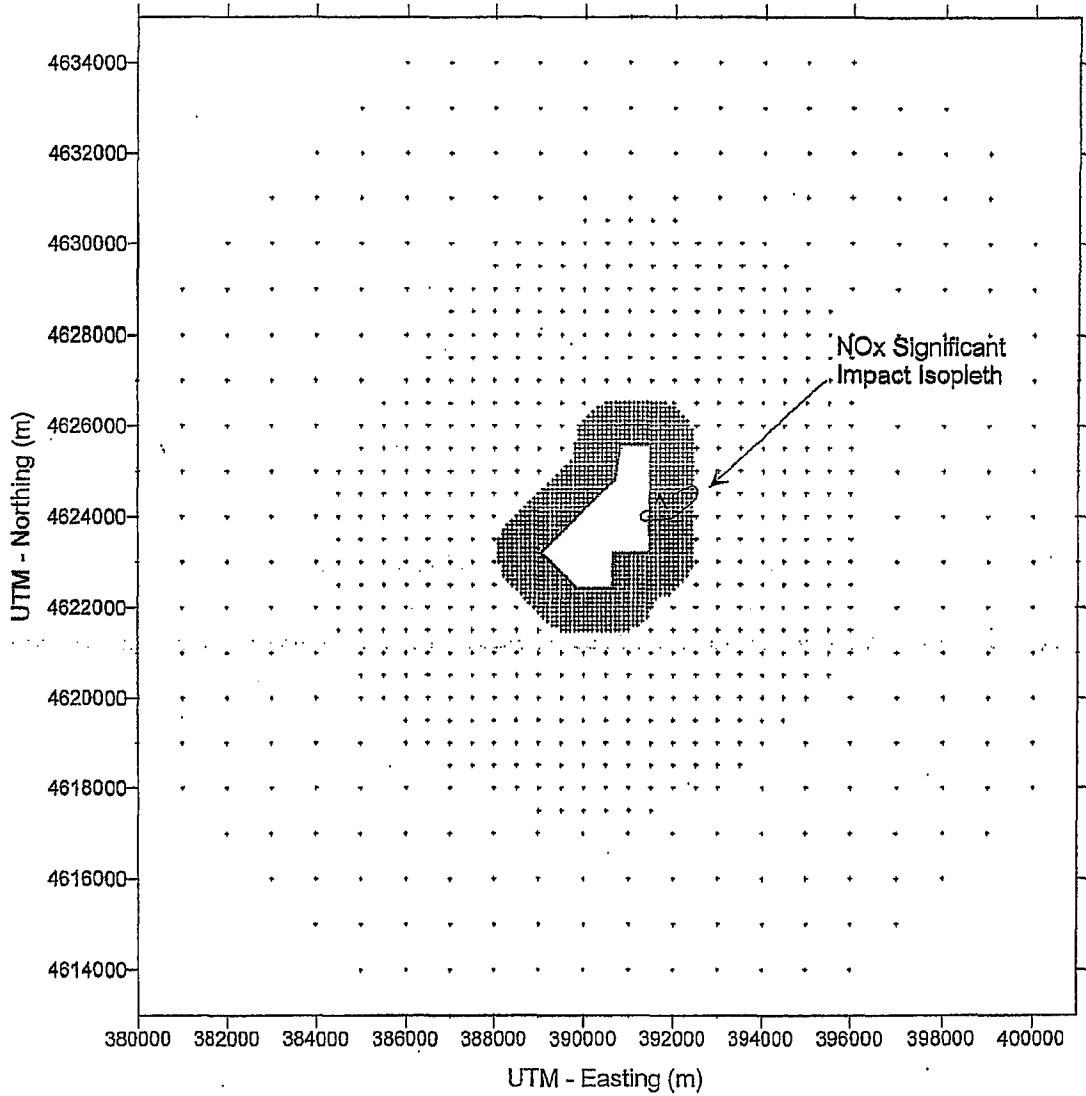
For example, the significant impact isopleths are depicted in Figure 6.7 through Figure 6.9 for the maximum annual NO<sub>x</sub> values for 2003, the maximum 24-hour PM<sub>10</sub> values for 2005, and the maximum 24-hour SO<sub>2</sub> values for 2000.

The Black-Start generators contribute primarily to the maximum impacts because of the relatively low stack heights and downwash and maximum overlapping simulated operations. Normal operations at the facility will not include the Black-Start generator emissions and therefore the impacts shown will be lowered. This suggests that the impacts from the MBFP operations will be minimal and likely insignificant for normal planned operations at the facility.

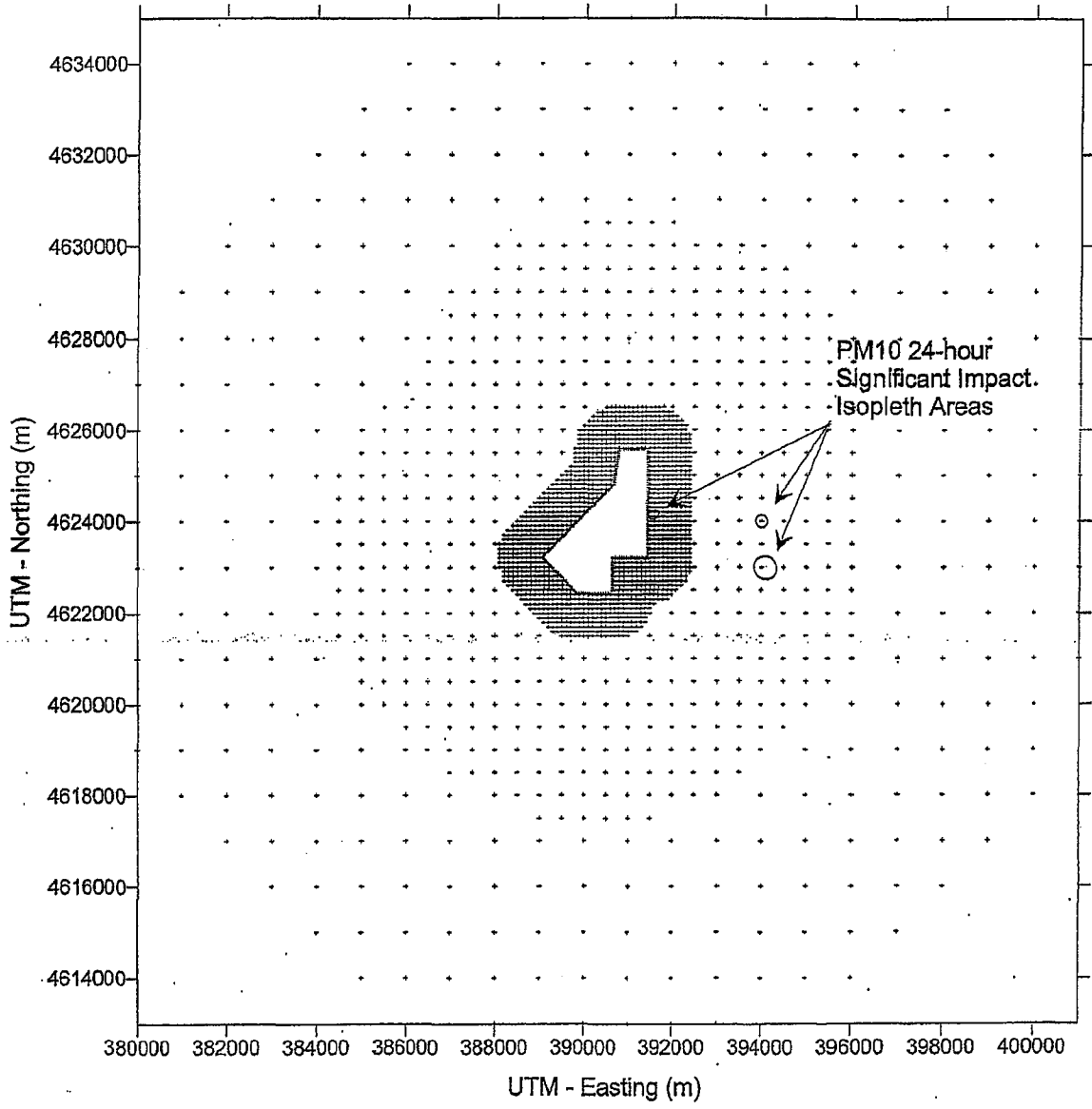
The modeling files for all the pollutants can be found in Appendix E of the June 19, 2007 application.



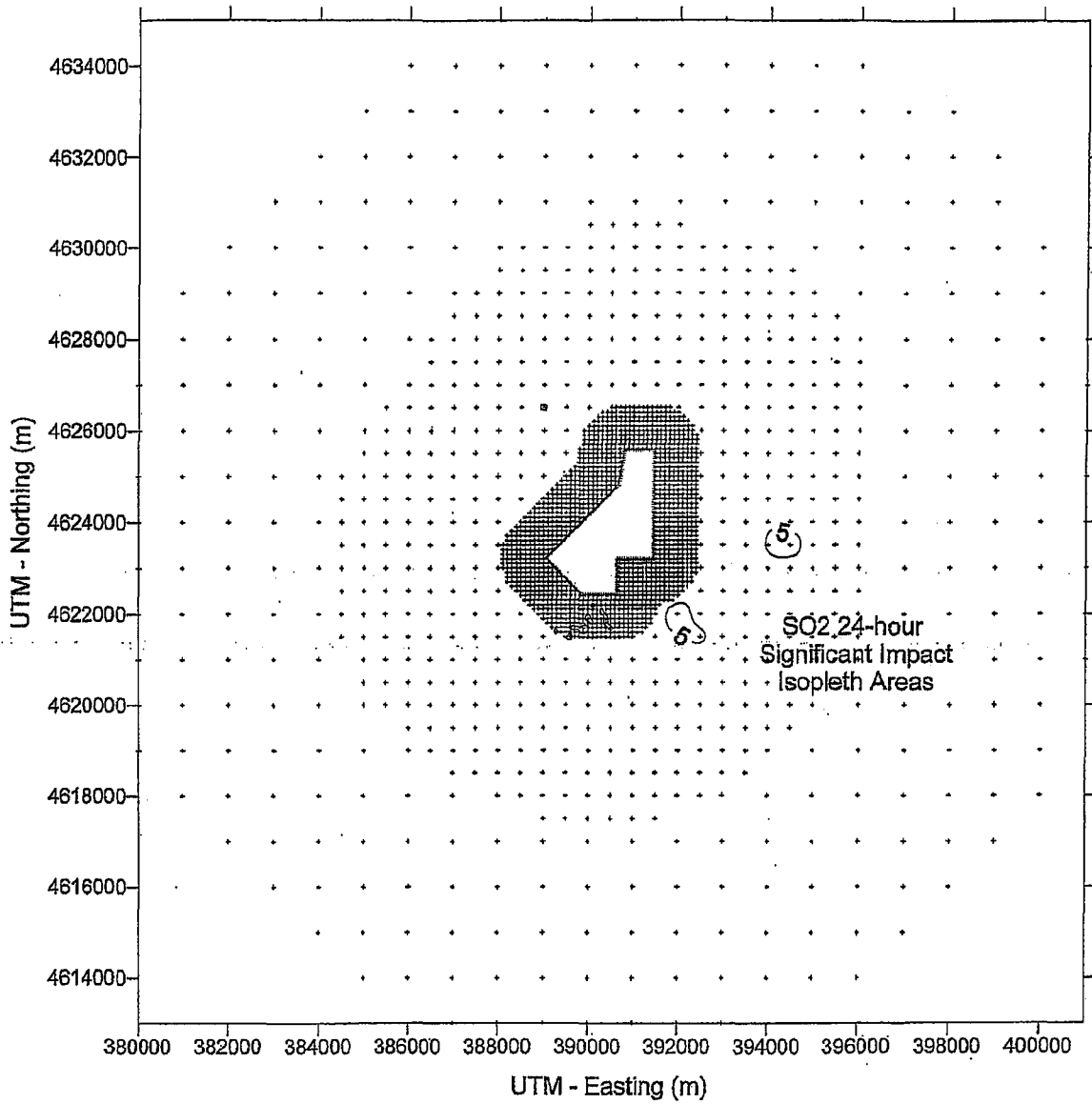
**Figure 6.7 – NO<sub>x</sub> Impact Area**



**Figure 6.8 – PM<sub>10</sub> 24-hour Impact Area**



**Figure 6.9 – SO<sub>2</sub> 24-hour Impact Area**



## 7.1 BACKGROUND

*NOTE: The far field modeling analysis presented in this section is based on emissions and process parameters described in the original Permit Application dated June 19, 2007. This analysis is presented in its entirety to comprehensively describe the modeling conducted for the June 2007 permit application. The far field modeling analysis was supplemented on October 17, 2007 in response to comments from the WDEQ. These responses are included in Appendix J.*

*MBFP believes that this far field criteria pollutant modeling analysis should be considered to be sufficient with regard to criteria pollutants emitted by the proposed facility based on the revised process design. A comparison of revised emission rates and previously modeled emission rates is presented in Appendix I.*

MBFP is proposing to construct 13,000-barrel per day (BPD) Industrial Gasification & Liquefaction Plant near Medicine Bow, Wyoming. As discussed in Section 1.2 of this application, the project is a major stationary source under the PSD program and therefore has completed an analysis of potential long-range impacts in support of a requested air quality construction permit. The proposed project is scheduled to start construction in the spring of 2008 with the construction being complete by December 2010.

Air quality impact analysis for Class I and sensitive Class II areas within 300 km from the project was conducted using the EPA long-range dispersion model, CALPUFF. The CALPUFF analysis included 8 Class I areas and 1 Class II area. The nearest Class I area, which is Mount Zirkel Wilderness, is located approximately 93 km southwest from the facility. Class I and sensitive Class II areas within 300 km from the facility are listed in Table 7.1. There is one sensitive Class II area within 300 km from the facility, named Savage Run, which is located approximately 60 km south from the facility.

In addition, soils and vegetation analysis was conducted. Additional impact analysis was not conducted because modeling results did not show significant air quality impact on Class I and sensitive Class II areas. Therefore, visibility analysis for scenic and important views and impact analysis for water was not conducted and the additional analyses areas are not listed in the Table 7-1.

Table 7.1 – Class I Areas and Sensitive Class II Areas Within 300 km

Areas	
Class I Areas	Rocky Mountain National Park, Rawah Wilderness, Flat Tops Wilderness, Eagles nest Wilderness, Mount Zirkel Wilderness, Maroon Bell-Snowmass Wilderness, Bridger Wilderness, and Fitzpatrick Wilderness
Sensitive Class II Areas	Savage Run

CALPUFF modeling runs were completed for each Class I or Class II area using a worst-case emission inventory. Detailed descriptions of the emission inventories for the modeling analysis were shown in Section 7.2.2.

**7.2 DESCRIPTION OF PROPOSED PROJECT****7.2.1 Site Location**

The facility will be located approximately 7.5 miles north of Interstate 80, exit 260 (Elk Mountain) on County Road #3 in Section 29 of Township 21 north and Range 79 west in Carbon County, Wyoming. LULC shapefile plotted in ArcGIS shows that most of the area surrounded by the facility is shrub/brush. MBFP will be located in an area that is designated as attainment of all National Ambient Air Quality Standards (NAAQS). The project location for the site is shown in Figure 1.1.

**7.2.2 Source Emissions**

The facility will consist of the Plant and the Underground coal mine (Saddleback Hills). Construction of both the Plant and the Mine will take about three years. The combustion source at the site will be fuels with syngas during normal operation and pipeline quality natural gas during startup and in the event of a loss of fuel gas (syngas). The facility will require approximately 1000 hours to start all of the process. Once the facility is started, it will not shut down unless there are planned maintenance activity or in the event of a malfunction. The startup is discussed in more detail in Section 2.17 of this application.

Emissions sources will include three (3) combustions turbines, twelve (12) heaters, three (3) generators, one (1) firewater pump, one (1) Emergency Flare, one (1) CO<sub>2</sub> vent, and one (1) Sulfur Plant Incinerator. Detailed emission calculations for these sources are included in Appendix B.

**7.2.3 Sources Included in CALPUFF Modeling**

Required emissions in CALPUFF correspond with the needed analysis and include maximum short-term rates for increment and visibility impacts, as well as maximum annual emissions for species deposition and increment comparison. Because of the various operations involved and potential occurrence during a specific period, the CALPUFF modeled sources and emissions included potential overlapping operations.

The emission rate derivation is shown in Table 7.2 and the modeled emissions are shown in Table 7.3 (short-term) and Table 7.4 (annual). The overlapping scenarios include the Turbine/HRSG 3 aggregated NO<sub>x</sub> emissions and the additive source emissions to account for normal and startup scenarios.

For example, in Table 7.2 the NO<sub>x</sub> emission rates shown for source Turbine and HRSG Train 3 feature a higher rate than for the other two turbines. This is done to reflect startup scenarios that would include 18-hours of normal operations and 6-hours of startup operations. Aggregating the two and rating the hourly emissions for each type of operation returns the 24-hour emission rate shown. And the annual emission inventory includes both normal and startup sources, as operating with the annual hours provided.

The CALPUFF modeling also included speciation of emissions according to the National Park Service (NPS)'s Particulate Matter Speciation (PMS) method for natural gas combustion turbines. Applying the PMS methodology, 67% of total SO<sub>2</sub> was speciated into SO<sub>2</sub> and 33% of

total SO<sub>2</sub> was speciated into SO<sub>4</sub>. Also, the total PM<sub>10</sub> emission was speciated into Elemental Carbon (EC) and Secondary Organic Aerosol (SOA). The SOA was speciated again into PM<sub>0.05</sub>, PM<sub>0.01</sub>, PM<sub>0.15</sub>, PM<sub>0.20</sub>, PM<sub>0.25</sub>, and PM<sub>1.0</sub> (indicated as PM0005, PM0010, PM0015, PM0020, PM0025, and PM0100 in the modeling, respectively). The SOA size distribution is shown in Table 7.5.

**Table 7.2 – Maximum Emission Rate from All Sources**

Pollutant	24-hour Averaged Emission Rate (lb/hr)									Annual Averaged Emission Rate		
	Startup	Normal	Startup	Normal	Startup	Normal	Total Maximum			Total Maximum		
	24-hr	24-hr	3 and 24-hr	3 and 24-hr	24-hr	24-hr	NO <sub>x</sub>	SO <sub>2</sub>	PM <sub>10</sub>	NO <sub>x</sub>	SO <sub>2</sub>	PM <sub>10</sub>
	NO <sub>x</sub>	NO <sub>x</sub>	SO <sub>2</sub>	SO <sub>2</sub>	PM <sub>10</sub>	PM <sub>10</sub>	NO <sub>x</sub>	SO <sub>2</sub>	PM <sub>10</sub>	NO <sub>x</sub>	SO <sub>2</sub>	PM <sub>10</sub>
Turbine and HRSG Train 1	134.56	18.15	0.04	0.04	10.00	10.00	18.15	0.04	10.00	17.51	0.04	10.00
Turbine and HRSG Train 2	134.56	18.15	0.04	0.04	10.00	10.00	18.15	0.04	10.00	17.51	0.04	10.00
Turbine and HRSG Train 3	134.56	18.15	0.04	0.04	10.00	10.00	47.25	0.04	10.00	17.51	0.04	10.00
Gasifier Preheater 1	0.74		0.01		0.11		0.74	0.01	0.11	0.04	5.04E-04	6.38E-03
Gasifier Preheater 2	0.74		0.01		0.11		0.74	0.01	0.11	0.04	5.04E-04	6.38E-03
Gasifier Preheater 3	0.74		0.01		0.11		0.74	0.01	0.11	0.04	5.04E-04	6.38E-03
Gasifier Preheater 4	0.74		0.01		0.11		0.74	0.01	0.11	0.04	5.04E-04	6.38E-03
Gasifier Preheater 5	0.74		0.01		0.11		0.74	0.01	0.11	0.04	5.04E-04	6.38E-03
H-3102 SRU Incinerator		0.13		9.51		2.04	0.13	9.51	2.04	0.13	9.51	2.04
H-5401 Frac Feed Heater	4.26	2.16	0.05	0.02	0.65	0.04	2.68	0.03	0.19	2.15	2.42E-02	0.07
H-5301 Cat Dewax Charge	0.19	0.10	0.00	0.00	0.03	0.24	0.12	0.00	0.24	0.10	1.08E-03	0.22
H-5201 Unicracker Feed	0.80	0.40	0.01	0.00	0.12	1.02	0.50	0.01	1.02	0.40	4.54E-03	0.91
H-5202 Unicracker Intermed.	2.17	1.10	0.03	0.01	0.33	2.75	1.36	0.02	2.75	1.10	1.23E-02	2.46
H-5101 Unionfiner Feed	0.25	0.13	0.00	0.00	0.04	0.32	0.16	0.00	0.32	0.13	1.42E-03	0.28
H-5102 Unionfiner Intermed	0.31	0.16	0.00	0.00	0.05	0.40	0.20	0.00	0.40	0.16	1.78E-03	0.35
Firewater Pump		6.02		0.01		0.08	6.02	0.01	0.08	0.18	3.27E-04	4.29E-05
Black-Start Generator 1										0.18	3.27E-04	4.29E-05
Black-Start Generator 2										0.18	3.27E-04	4.29E-05
Black-Start Generator 3										0.34	3.46E-04	4.34E-03
<b>Total</b>							<b>98</b>	<b>10</b>	<b>38</b>	<b>58</b>	<b>10</b>	<b>36</b>

# SECTION SEVEN

# Far Field Air Quality Impact Analysis

Table 7.3 – 24 hour Averaged Emission Inventory for CALPUFF (3-hour and 24-hour SO<sub>2</sub>, and 24-hour PM<sub>10</sub> and Visibility)

Sources (g/s)	SO <sub>2</sub>	SO <sub>x</sub>	NO <sub>x</sub>	HNO <sub>3</sub>	NO <sub>3</sub>	INCPM	SOA						SOA	EC
							PM0005	PM0010	PM0015	PM0020	PM0025	PM0100		
Turbine and HRSG Train 1	3.54E-03	2.65E-03	2.29E+00	0.00E+00	0.00E+00	1.26E+00	1.41E-01	2.36E-01	2.17E-01	1.41E-01	1.04E-01	1.04E-01	9.42E-01	3.15E-01
Turbine and HRSG Train 2	3.54E-03	2.65E-03	2.29E+00	0.00E+00	0.00E+00	1.26E+00	1.41E-01	2.36E-01	2.17E-01	1.41E-01	1.04E-01	1.04E-01	9.42E-01	3.15E-01
Turbine and HRSG Train 3	3.59E-03	2.69E-03	5.95E+00	0.00E+00	0.00E+00	1.26E+00	1.41E-01	2.36E-01	2.17E-01	1.41E-01	1.04E-01	1.04E-01	9.42E-01	3.15E-01
Gasifier Preheater 1	7.41E-04	5.56E-04	9.26E-02	0.00E+00	0.00E+00	1.41E-02	1.50E-03	2.50E-03	2.30E-03	1.50E-03	1.10E-03	1.10E-03	1.00E-02	3.52E-03
Gasifier Preheater 2	7.41E-04	5.56E-04	9.26E-02	0.00E+00	0.00E+00	1.41E-02	1.50E-03	2.50E-03	2.30E-03	1.50E-03	1.10E-03	1.10E-03	1.00E-02	3.52E-03
Gasifier Preheater 3	7.41E-04	5.56E-04	9.26E-02	0.00E+00	0.00E+00	1.41E-02	1.50E-03	2.50E-03	2.30E-03	1.50E-03	1.10E-03	1.10E-03	1.00E-02	3.52E-03
Gasifier Preheater 4	7.41E-04	5.56E-04	9.26E-02	0.00E+00	0.00E+00	1.41E-02	1.50E-03	2.50E-03	2.30E-03	1.50E-03	1.10E-03	1.10E-03	1.00E-02	3.52E-03
Gasifier Preheater 5	7.41E-04	5.56E-04	9.26E-02	0.00E+00	0.00E+00	1.41E-02	1.50E-03	2.50E-03	2.30E-03	1.50E-03	1.10E-03	1.10E-03	1.00E-02	3.52E-03
H-3102 SRU Inoinerator	7.99E-01	5.99E-01	1.64E-02	0.00E+00	0.00E+00	2.57E-01	0.00E+00	0.00E+00	0.00E+00	0.00E+00	0.00E+00	0.00E+00	0.00E+00	6.42E-02
H-5401 Frac Feed Heater	2.59E-03	1.94E-03	3.38E-01	0.00E+00	0.00E+00	2.44E-02	2.45E-03	4.09E-03	3.76E-03	2.45E-03	1.80E-03	1.80E-03	1.63E-02	6.10E-03
H-5301 Cat Dewax Charge	1.16E-04	8.70E-05	1.52E-02	0.00E+00	0.00E+00	3.05E-02	3.42E-03	5.70E-03	5.25E-03	3.42E-03	2.51E-03	2.51E-03	2.28E-02	7.63E-03
H-5201 Unicracker Feed	4.86E-04	3.64E-04	6.35E-02	0.00E+00	0.00E+00	1.28E-01	1.43E-02	2.39E-02	2.20E-02	1.43E-02	1.05E-02	1.05E-02	9.56E-02	3.20E-02
H-5202 Unicracker Intermed.	1.32E-03	9.87E-04	1.72E-01	0.00E+00	0.00E+00	3.47E-01	3.88E-02	6.47E-02	5.96E-02	3.88E-02	2.85E-02	2.85E-02	2.59E-01	8.66E-02
Firewater Pump	1.52E-04	1.14E-04	1.99E-02	0.00E+00	0.00E+00	4.01E-02	4.50E-03	7.50E-03	6.90E-03	4.50E-03	3.30E-03	3.30E-03	3.00E-02	1.00E-02



# SECTION SEVEN

# Far Field Air Quality Impact Analysis

Table 7.4 – Annual Averaged Emission Inventory for CALPUFF (Annual NO<sub>x</sub>, SO<sub>2</sub>, and PM<sub>10</sub> and Deposition)

Sources (g/s)	SO <sub>2</sub>	SO <sub>x</sub>	NO <sub>x</sub>	HNO <sub>3</sub>	NO <sub>3</sub>	INCPM	SOA						SOA	EC
							PM0005	PM0010	PM0015	PM0020	PM0025	PM0100		
Turbine and HRSG Train 1	3.42E-03	2.57E-03	2.21E+00	0.00E+00	0.00E+00	1.26E+00	1.41E-01	2.36E-01	2.17E-01	1.41E-01	1.04E-01	1.04E-01	9.42E-01	3.15E-01
Turbine and HRSG Train 2	3.42E-03	2.57E-03	2.21E+00	0.00E+00	0.00E+00	1.26E+00	1.41E-01	2.36E-01	2.17E-01	1.41E-01	1.04E-01	1.04E-01	9.42E-01	3.15E-01
Turbine and HRSG Train 3	3.42E-03	2.57E-03	2.21E+00	0.00E+00	0.00E+00	1.26E+00	1.41E-01	2.36E-01	2.17E-01	1.41E-01	1.04E-01	1.04E-01	9.42E-01	3.15E-01
Gasifier Preheater 1	4.23E-05	3.17E-05	5.29E-03	0.00E+00	0.00E+00	8.04E-04	8.57E-05	1.43E-04	1.31E-04	8.57E-05	6.28E-05	6.28E-05	5.71E-04	2.01E-04
Gasifier Preheater 2	4.23E-05	3.17E-05	5.29E-03	0.00E+00	0.00E+00	8.04E-04	8.57E-05	1.43E-04	1.31E-04	8.57E-05	6.28E-05	6.28E-05	5.71E-04	2.01E-04
Gasifier Preheater 3	4.23E-05	3.17E-05	5.29E-03	0.00E+00	0.00E+00	8.04E-04	8.57E-05	1.43E-04	1.31E-04	8.57E-05	6.28E-05	6.28E-05	5.71E-04	2.01E-04
Gasifier Preheater 4	4.23E-05	3.17E-05	5.29E-03	0.00E+00	0.00E+00	8.04E-04	8.57E-05	1.43E-04	1.31E-04	8.57E-05	6.28E-05	6.28E-05	5.71E-04	2.01E-04
Gasifier Preheater 5	4.23E-05	3.17E-05	5.29E-03	0.00E+00	0.00E+00	8.04E-04	8.57E-05	1.43E-04	1.31E-04	8.57E-05	6.28E-05	6.28E-05	5.71E-04	2.01E-04
H-3102 SRU Incinerator	7.99E-01	5.99E-01	1.64E-02	0.00E+00	0.00E+00	2.57E-01	0.00E+00	0.00E+00	0.00E+00	0.00E+00	0.00E+00	0.00E+00	0.00E+00	6.42E-02
H-5401 Frac Feed Heater	2.03E-03	1.52E-03	2.71E-01	0.00E+00	0.00E+00	9.35E-03	8.23E-04	1.37E-03	1.26E-03	8.23E-04	6.03E-04	6.03E-04	5.48E-03	2.34E-03
H-5301 Cat Dewax Charge	9.11E-05	6.83E-05	1.22E-02	0.00E+00	0.00E+00	2.73E-02	3.06E-03	5.09E-03	4.69E-03	3.06E-03	2.24E-03	2.24E-03	2.04E-02	6.81E-03
H-5201 Unicracker Feed	3.82E-04	2.86E-04	5.09E-02	0.00E+00	0.00E+00	1.14E-01	1.28E-02	2.13E-02	1.96E-02	1.28E-02	9.39E-03	9.39E-03	8.54E-02	2.86E-02
H-5202 Unicracker Intermed.	1.03E-03	7.76E-04	1.38E-01	0.00E+00	0.00E+00	3.09E-01	3.47E-02	5.78E-02	5.32E-02	3.47E-02	2.54E-02	2.54E-02	2.31E-01	7.74E-02
H-5101 Unionfiner Feed	1.20E-04	8.98E-05	1.60E-02	0.00E+00	0.00E+00	3.58E-02	4.02E-03	6.69E-03	6.16E-03	4.02E-03	2.95E-03	2.95E-03	2.68E-02	8.95E-03
H-5102 Unionfiner Intermed.	1.49E-04	1.12E-04	1.99E-02	0.00E+00	0.00E+00	4.46E-02	5.01E-03	8.34E-03	7.68E-03	5.01E-03	3.67E-03	3.67E-03	3.34E-02	1.12E-02
Black-Start Generator 1	2.75E-05	2.06E-05	2.29E-02	0.00E+00	0.00E+00	5.40E-06	0.00E+00	0.00E+00	0.00E+00	0.00E+00	0.00E+00	0.00E+00	0.00E+00	1.35E-06
Black-Start Generator 2	2.75E-05	2.06E-05	2.29E-02	0.00E+00	0.00E+00	5.40E-06	0.00E+00	0.00E+00	0.00E+00	0.00E+00	0.00E+00	0.00E+00	0.00E+00	1.35E-06
Black-Start Generator 3	2.75E-05	2.06E-05	2.29E-02	0.00E+00	0.00E+00	5.40E-06	0.00E+00	0.00E+00	0.00E+00	0.00E+00	0.00E+00	0.00E+00	0.00E+00	1.35E-06
Firewater Pump	2.91E-05	2.18E-05	4.33E-02	0.00E+00	0.00E+00	5.47E-04	5.83E-05	9.71E-05	8.93E-05	5.83E-05	4.27E-05	4.27E-05	3.88E-04	1.37E-04

Table 7.5 – Size Distribution of Secondary Organic Aerosols (SOA)

Species Name	Size Distribution (%)	Geometric Mass Mean Diameter (microns)	Geometric Std Deviation (microns)
SO <sub>4</sub>	100	0.48	0.50
NO <sub>3</sub>	100	0.48	0.50
PM0005	15	0.05	0.00
PM0010	40	0.10	0.00
PM0015	63	0.15	0.00
PM0020	78	0.20	0.00
PM0025	89	0.25	0.00
PM0100	100	1.00	0.00

The 24-hour averaged emission rate was used for the 3-hour and 24-hour SO<sub>2</sub> and 24-hour PM<sub>10</sub> impact analyses, and visibility impairment impact analysis. The annual emission rate was used for the annual NO<sub>x</sub>, annual SO<sub>2</sub>, and annual PM<sub>10</sub> impact analyses as well as nitrogen and sulfur deposition analyses. The stack parameters of all sources are shown in Table 7.6.

#### 7.2.4 Reference Reports

This air quality impact analysis modeling report was prepared based on written protocol comment guidance received from the WDEQ on May 5, 2007 as well as pre-application meeting with WDEQ on July 11, 2006, a conference call with representatives of the WDEQ on March 7, 2007, and protocol submitted to WDEQ on February 8, 2007. The following guidance documents were also consulted:

1. Wyoming Department of Environmental Quality/ Air Division Quality Requirements for Submitting Modeling Analyses (March 1, 2006)
2. Interagency Workgroup on Air Quality Modeling Phase 2 Summary Report and Recommendations for Modeling Long Range Transport Impacts (EPA-454/R-98-019) (IWAQM2) (December, 1998)
3. Federal Land Managers Air Quality Related Values Work Group Phase I report (FLAG) (USFS, NPS, USFWS, 2000)
4. U.S. Environmental Protection Agency (EPA) Guidelines on Air Quality Models (GAQM) (November 9, 2005)

Table 7.6 – Source Location and Parameter

Source Description	Source ID	UTM NAD27 Easting (m)	UTM NAD27 Northing (m)	LCC X (km)	LCC Y (km)	Base Elevation (m)	Stack Height (m)	Stack Temperature (K)	Stack Velocity (m/s)	Stack Diameter (m)
Turbine and HRSG Train 1	94.20548	391370.8502	4623838.482	94.2055	57.3291	2115.03	45.73	366.493	7.6476	5.79268
Turbine and HRSG Train 2	94.20554	391369.1877	4623777.21	94.2055	57.2678	2115.19	45.73	366.493	7.6476	5.79268
Turbine and HRSG Train 3	94.20561	391367.5348	4623716.29	94.2056	57.2068	2113.97	45.73	366.493	7.6476	5.79268
Gasifier Preheater 1	93.88945	391050.5564	4623693.356	93.8895	57.175	2117.34	25.91	422.06	7.44635	0.4065
Gasifier Preheater 2	93.88946	391050.2258	4623681.172	93.8895	57.1628	2116.41	25.91	422.06	7.44635	0.4065
Gasifier Preheater 3	93.88948	391049.8952	4623668.988	93.8895	57.1506	2115.6	25.91	422.06	7.44635	0.4065
Gasifier Preheater 4	93.88949	391049.5647	4623656.804	93.8895	57.1384	2114.91	25.91	422.06	7.44635	0.4065
Gasifier Preheater 5	93.88951	391049.2341	4623644.62	93.8895	57.1262	2114.5	25.91	422.06	7.44635	0.4065
H-3102 SRU Incinerator	93.96448	391137.24	4624096.22	93.9645	57.5798	2121.68	45.73	422.06	0.1285	4.57
H-5401 Frao Feed Heater	94.12435	391299.1329	4624173.23	94.1244	57.6616	2117.36	45.73	422.06	4.79348	1.21951
H-5301 Cat Dewax Charge	94.09279	391267.3293	4624164.97	94.0928	57.6525	2119.98	15.24	422.06	1.93335	0.4065
H-5201 Unicracker Feed	94.09533	391266.5292	4624046.993	94.0953	57.5345	2118.57	15.24	422.06	1.60033	0.91463
H-5202 Unicracker Intermed.	94.09777	391270.0084	4624083.457	94.0978	57.5711	2117.22	30.48	422.06	3.18521	1.06707
H-5101 Unionfiner Feed	94.12376	391294.9586	4624046.221	94.1238	57.5346	2116.81	15.24	422.06	2.02689	0.50813
H-5102 Unionfiner Intermed	94.11973	391292.8241	4624113.299	94.1197	57.6015	2115.13	15.24	422.06	2.54097	0.4065
Black-Start Generator 1	94.13621	391303.589	4623910.942	94.1362	57.3996	2117.18	6.097	767.604	1.96249	0.4065
Black-Start Generator 2	94.13669	391303.8135	4623901.81	94.1367	57.3905	2117.48	6.097	767.604	1.96249	0.4065
Black-Start Generator 3	94.13659	391303.4502	4623892.553	94.1366	57.3812	2117.58	6.097	767.604	1.96249	0.4065
Firewater Pump	94.12873	391286.31	4623564	94.1287	57.0523	2103.98	6.10	739.27	45	0.15

### 7.3 LONG-RANGE TRANSPORT MODELING METHOD

#### 7.3.1 Long-Range Transport Modeling

A PSD analysis of increment and AQRV impacts on Class I and sensitive Class II areas will be performed if any Class I or sensitive Class II areas are located within 300 kilometers of the proposed project location. There are eight Class I areas within 300 km from the facility that will be accounted for this analysis. The nearest Class I area is the Mount Zirkel Wilderness, which is located approximately 93 km south from the project. The second nearest Class I area is the Rawah Wilderness, which is located approximately 102 km south from the project. Rocky Mountain NP and Flat Tops Wilderness Class I areas are located approximately 144 km and 192 km south from the facility, respectively. Eagles Nest Wilderness and Maroon Bell-Snowmass Wilderness Class I areas are located 214 km and 283 km south from the facility, respectively. Bridger Wilderness and Fitzpatrick Wilderness Class I areas are located 242 km and 294 km northwest from the facility, respectively. The sensitive Class II area is Savage Run which is located 60 km south from the facility. The locations of the Class I, sensitive Class II areas, and the facility are shown in Figure 7.1.

The analyses performed include the following:

- PSD Class I Increment modeling significance levels
- Visibility reduction thresholds,
- US National Park Service (USNPS) and US Fish and Wildlife Service (USFWS) deposition analysis thresholds (DAT), and
- Soil and Vegetation Analysis

Additional Air Quality Related Value (AQRV) impact analyses were not conducted because the modeling results did not demonstrate a significant impact on air quality in the Class I and sensitive Class II areas. Because there were no significant increment and visibility impacts on Class I and sensitive Class II areas, it was considered that none of visibility analysis for scenic and important views and impact analysis for water has significant impact.

#### 7.3.2 Model Selection and Setup

To estimate air quality impacts at distances greater than 50 km, the CALPUFF model was used in conjunction with the CALMET diagnostic meteorological model. CALPUFF is a puff-type model that can incorporate three-dimensionally varying wind fields, wet and dry deposition, and atmospheric gas and particle phase chemistry.

The CALMET model is used to prepare the necessary gridded wind fields for use in the CALPUFF model. CALMET can accept as input; mesoscale meteorological data (MM5 data), surface station, upper air, precipitation, cloud cover, and over-water meteorological data (all in a variety of input formats). These data are merged and the effects of terrain and land cover types are estimated. This process results in the generation of gridded 3-D wind field that accounts for the effects of slope flows, terrain blocking effects, flow channelization, and spatially varying land use types.

The development of model inputs and options for both the CALMET and CALPUFF processors was based on guidance provided in following references:

- 1 Wyoming DEQ/Air Quality Division Requirements for Submitting Modeling Analyses (3/06)
- 2 Interagency Working Group on Air Quality Modeling (IWAQM) Phase 2 Summary Report and Recommendations for Modeling Long Range Transport Impacts (December 1998), and
- 3 Permit application PSD particulate matter speciation methodology developed by Don Shepherd, National Park Service (2006).

Key input and model options selected are discussed in the following sections.

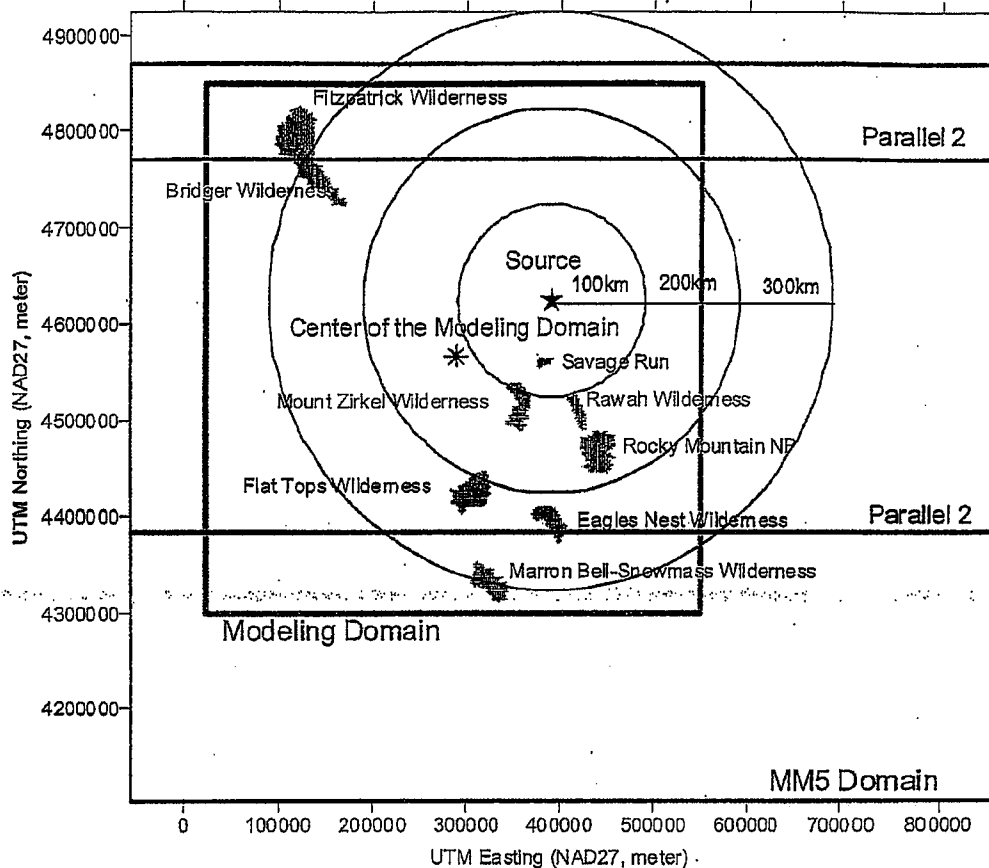
The EPA-approved version of the CALMET/CALPUFF/CALPOST system (CALPUFF of version 5.711a, CALMET of version 5.53a, and CALPOST of version 5.51) was used. Copies of all executable files used in the preparation of this modeling analysis are provided. As requested by the WDEQ, CALMET, CALPUFF, and CALPOST input and output files are provided electronically in Appendix E of the June 19, 2007 application.

### **7.3.3 Domain**

The modeling domain was specified using the Lambert Conformal Conic (LCC) Project system in order to capture the earth curvature of the large modeling domain more accurately for this project. The false easting and northing at the projection origin were set to both zeros. The latitude and longitude of projection origin were set to 41.25 N and 107.44 W, respectively. Matching parallel of latitude 1 and 2 were defined as 39.57 N and 42.94 N, respectively. The modeling domain was defined using a grid-cell arrangement that is 131 cells in X (easting) direction and 137 cells in Y (northing) direction. The grid-cells are 4 kilometers wide. Therefore, the southwest corner of the grid cell (1,1) was set to -321.65 km and -272.07 km.

Approximately 130 km of buffer distance was set between the most east side of the Class I area and the east boundary of the modeling domain. Although 50 km of buffer distance meets the WDEQ's minimum criteria and there is no Class I area in the far east of the project location, 80 km of additional buffer distance was added to the 50 km of buffer distance to prevent the loss of mass outside the boundary under some meteorological scenario that might be associated with transport to nearby Class I areas. The modeling domain, origin of the modeling domain, and the parallels is shown in Figure 7.1 based on UTM coordinate.

Figure 7.1 – Relative Location of Modeling Domain, MM5 Domain, Class I and Sensitive Class II areas, and Source based on UTM Coordinates



#### 7.3.4 LULC and TERREL Processing

The CALMET and CALPUFF models incorporate assumptions regarding land-use classification, leaf-area index, and surface roughness length to estimate deposition during transport. U.S. Geological Survey (USGS) 1:250,000 scale digital elevation models (DEMs) and Land Use Land Cover (LULC) classification files were obtained and used to develop the geophysical input files required by the CALMET model. U.S. Geological Survey (USGS) 1:250,000 scale digital elevation models (DEMs) data were obtained from the Lakes Environmental website, [http://www.webgis.com/terr\\_us1deg.html](http://www.webgis.com/terr_us1deg.html). Using thirty nine (39) 1-degree DEM data files obtained, terrain pre-processor (TERREL) was processed to produce gridded fields of terrain elevation in the formats compatible with the CALMET.

LULC data (\*.gz) were obtained from USGS 250K site, <http://edcftp.cr.usgs.gov/pub/data/LULC/250K/>. Land Use Data Preprocessors, CTGCOMP and CTGPROC were processed to compress twenty six (26) LULC data files obtained. The outputs

of TERREL and CTGPROC were combined in the geo-physical preprocessor (MAKEGEO) to prepare the CALMET geo-physical input file. These inputs include land use type, elevation, surface parameters (surface roughness, length, albedo, Bowen ratio, soil heat flux parameter, and vegetation leaf area index) and anthropogenic heat flux.

Input files for TERREL, CTGPROC, and MAKEGEO are supplied electronically in Appendix E of the June 19, 2007 application. The modeling domain is shown in Figure 7.2.

### **7.3.5 Hourly Surface and Precipitation Data**

Three years of CALMET-ready hourly surface meteorological data and precipitation data for the project modeling domain were provided by WDEQ. The hourly surface data and precipitation data of the "SEWY" section among the data that WDEQ provided were used for the project CALMET modeling. Hourly surface data are from 30 different stations and precipitation data are from 108 different stations. The LCC coordinates of the surface meteorological stations and precipitation stations in the CALMET input files were modified based on the LCC projection.

### **7.3.6 Upper Air Sounding Data**

Upper air sounding data were provided by WDEQ. Three years (2001, 2002, and 2003) of upper air data from Denver Stapleton International Airport (Station # 23062), Grand Junction Walker Field (Station # 23066), Riverton Municipal Airport (Station # 24061), and Rapid City (Station # 94043). The LCC coordinates of the upper air data stations in the CALMET input files were modified based on the LCC projection.

### **7.3.7 MM5 Data**

Two years of MM5 data (2001 and 2002) were obtained from Colorado Department of Public Health and Environment (CDPHE) and one year of MM5 data (2003) was obtained from WDEQ. All three years MM5 data sets consist of a grid resolution of 36 kilometers. The 2001 and 2002 MM5 data consist by each month, but the 2003 MM5 data consist of one file as one year data. Three years of MM5 data were used for BART modeling for Western Regional Air Partnership (WRAP) by CDPHE and WDEQ.

### **7.3.8 CALMET**

Pursuant to FLAG guidance, a three-year meteorological data set was developed using a combination of surface, upper-air, and mesoscale meteorological (MM) data. All surface and upper-air data were obtained from WDEQ. Surface, upper-air, and MM data points were combined and used in the CALMET model.

Monthly CALMET wind fields were generated using a combination of MM5 data sets augmented with the surface, precipitation, and upper air data. Per IWAQM guidance, the

MM5 data are interpolated to the CALMET fine-scale grid to create the initial-guess wind fields (IProg = 14 for MM5). The initial guess wind fields are then adjusted for kinematic terrain effects, slope flows, and terrain blocking effects using the fine-scale CALMET terrain and land use data. The resulting wind fields are referred to as the Step 1 wind field. The observational

## SECTION SEVEN

## Far Field Air Quality Impact Analysis

NWS data are used to drive a diagnostic weighting between the Step 1 wind fields and the localized surface observations.

For all three years, ZIMAX (maximum overland mixing height) and the maximum ZFACE (top cell face height) was set as 3500 m as the WDEQ's "SEWY" CALMET input was set up. Thus, 3500 m of XMAXZI (maximum mixing height) and 3500 m of ZFACE value in CALPUFF were used.

Based on the WDEQ's "SEWY" CALMET input set up, 30 km of the maximum radius of influence over land in the surface layer (RMAX1), 50 km of the maximum radius of influence over land aloft (RMAX2), 5 km of the relative weighting of the first guess field and observations in the surface layer (R1), and 25 km of the relative weighting of the first guess field and observation in the layers ALOFT (R2) were used. 15 km of the TERRAD value was used per WDEQ's "SEWY" CALMET input. CALMET input and model options are presented in Table 7.7.

Table 7.7 – CALMET Model Options

CALMET Variable	Specified Value	Comment
NUSTA	1	Number of Upper Air Stations
PMAP	LCC	Map Projection – Lambert Conformal Conic
FEAST	0	False Easting (km)
FNORTH	0	False Northing (km)
RLAT0	41.25 N	Latitude of Projection Origin
RLON0	107.44 W	Longitude of Projection Origin
XLAT1	39.57 N	Matching parallel of latitude (decimal degrees) for projection
XLAT2	42.94 N	Matching parallel of latitude (decimal degrees) for projection
DATUM	NAS-C	Datum for Output Coordinates
NX	131	Number of Grid Cells in the X-direction
NY	137	Number of Grid Cells in the Y-direction
DGRIDKM	4	Grid Cell Spacing (km)
XORIGKM	-321.65	Reference grid coordinate of southwest corner of grid cell (1,1) X coordinate
YORIGKM	-272.07	Reference grid coordinate of southwest corner of grid cell (1,1) Y coordinate
NZ	10	Number of Vertical Layers (0, 20, 40, 100, 200, 350, 500, 750, 1000, 2000, 3500 m)
ZIMAX	3500 m for years	It is consistent with XMAXZI = 3500 m in CALPUFF option
NOOBS	0	Use Surface, Overwater, and Upper Air Stations
NSSTA	30	Number of surface stations
NPSTA	108	Number of precipitation stations

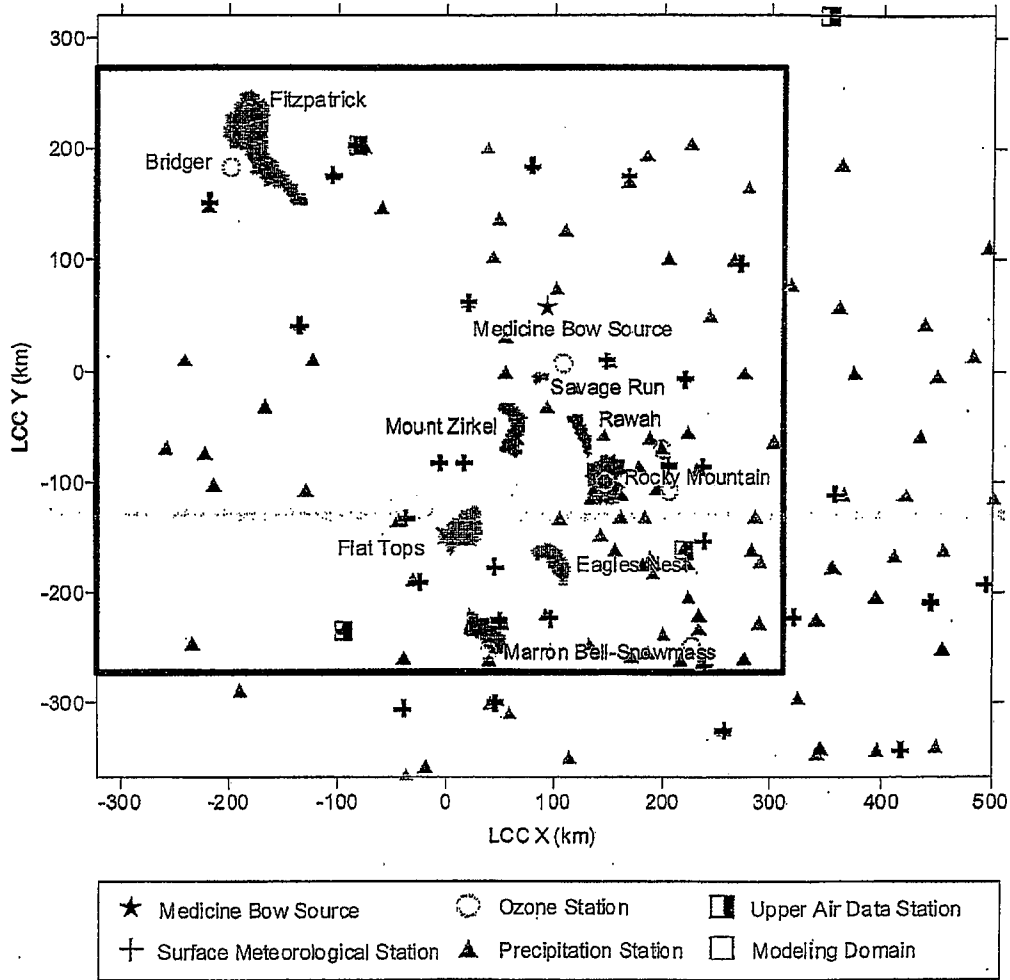


Table 7.7 – CALMET Model Options

CALMET Variable	Specified Value	Comment
ICLOUD	0	Gridded Cloud not used
IWFCOD	1	Diagnostic Wind Module (1 = yes)
IFRADJ	1	Froude Number Adjustment (1 = yes)
IKINE	0	Kinematic Effects (0 = no)
IOBR	0	O'Brien Vertical Velocity Adjustment (0 = no)
ISLOPE	1	Slope Flow Effects (1 = yes)
IEXTRP	-4	Surface Wind Extrapolation – similarity theory, ignore layer 1
ICALM	0	Extrapolate calm surface winds (0 = no)
RMIN2	4	Minimum Distance from Surface Station to Upper Air for which Extrapolation is allowed
IPROG	14	MM5 Data Used as Initial Guess Field
RMAX1	30	Maximum Overland Radius of Influence at Surface (km)
RMAX2	50	Maximum Overland Radius of Influence Aloft (km)
RMAX3	50	Maximum Overwater Radius of Influence (km)
RMIN	0.1	Minimum Radius of Influence in Wind Field Interpolation (km)
R1	5	Relative weighting of the first guess field and observations in the SURFACE layer (R1 is the distance from an observational station at which the observation and first guess field are equally weighted)
R2	25	Relative weighting of the first guess field and observations in the layers ALOFT
TERRAD	15	Radius of Influence of Terrain Features

Locations of the hourly surface meteorological stations, upper air sounding monitoring stations, precipitation data monitoring stations, and ozone monitoring stations are shown in Figure 7.2.

**Figure 7.2 – Modeling Domain with Receptors of Class I and Sensitive Class II Areas, Precipitation Data Monitoring Station, Ozone Monitoring Station, Surface Meteorological Data Monitoring Station, and Project Location**



**7.3.8.1 CALPUFF**

Size parameters for dry deposition of nitrate, sulfate, and PM<sub>10</sub> particles were based on default CALPUFF model options. Chemical parameters for gaseous dry deposition and wet scavenging coefficients were based on default values presented in the CALPUFF User's Guide. Calculation of total nitrogen deposition includes the contribution of nitrogen resulting from the ammonium ion of the ammonium sulfate compound. For the CALPUFF runs that incorporate deposition and chemical transformation rates (i.e., deposition and visibility), the full chemistry option of CALPUFF was turned on (MCHEM = 1). The nighttime loss for SO<sub>2</sub>, NO<sub>x</sub> and nitric acid (HNO<sub>3</sub>) was set at 0.2 percent per hour, 2 percent per hour and 2 percent per hour, respectively.

# SECTION SEVEN

## Far Field Air Quality Impact Analysis

CALPUFF was also configured to allow predictions of SO<sub>2</sub>, sulfate (SO<sub>4</sub>), NO<sub>x</sub>, HNO<sub>3</sub>, nitrate (NO<sub>3</sub>) and PM<sub>10</sub> using the MESOPUFF II chemical transformation module.

As described in Section 7.2, emissions were speciated in accordance with the National Park Service (NPS)'s Particulate Matter Speciation (PMS) guideline (<http://www2.nature.nps.gov/air/permits/ect/index.cfm>). In doing so, the sulfur emissions were speciated to relative sulfur constituents of SO<sub>2</sub> and SO<sub>4</sub> to better account for gas to particulate conversion and visibility effects.

CALPUFF input and model options are presented in Table 7.8. CALMET, CALPUFF, and CALPOST input files are provided electronically in Appendix E of the June 19, 2007 application.

**Table 7.8 – CALPUFF Model Options**

CALPUFF Variable	Specified Value	Comment
IBTZ	7	Base Time Zone
MGAUSS	1	Vertical Distribution Used In The Near Field
MCTADJ	3	Terrain Adjustment Method
MCTSG	0	Subgrid-Scale Complex Terrain Flag
MSLUG	0	Near-Field Puffs Modeled As Elongated 0
MTRANS	1	Transitional Plume Rise Modeled
MTIP	1	Stack Tip Downwash
MBDW	1	Building Downwash, 1= ISC method
MSHEAR	0	Vertical Wind Shear Modeled Above Stack Top
MSPLIT	0	Puff Splitting Allowed
MCHEM	1	Chemical Mechanism Flag
MWET	1	Wet Removal Modeled
MDRY	1	Dry Deposition Modeled
MDISP	3	Method Used To Compute Dispersion Coefficients
MROUGH	0	PG Sigma-Y,Z Adjusted For Roughness
MPARTL	1	Partial Plume Penetration Of Elevated Inversion (per IWAQM)
MTINV	0	Strength Of Temperature Inversion Provided In PROFILE.DAT Extended Records
MPDF	0	PDF Used For Dispersion Under Convective Conditions
MSGTIBL	0	Sub-Grid TIBL Module Used For Shore Line
MBCON	0	Boundary Conditions (Concentration) Modeled
MFOG	0	Configure For FOG Model Output
MREG	1	Test Options Specified To See If They Conform To Regulatory Values
PMAF	LCC	Map Projection
FEAST	0	False Easting (km)
FNORTH	0	False Northing (km)
RLAT0	41.25 N	Latitude of Projection Origin
RLON0	107.44 W	Longitude of Projection Origin

Table 7.8 – CALPUFF Model Options

CALPUFF Variable	Specified Value	Comment
XLAT1	39.57 N	Matching parallel of latitude (decimal degrees) for projection
XLAT2	42.94 N	Matching parallel of latitude (decimal degrees) for projection
NX	131	No. X Grid Cells
NY	137	No. Y Grid Cells
NZ	10	No. Vertical Layers
DGRIDK M	4	Grid Spacing (km)
ZFACE		0, 20, 40, 100, 200, 350, 500, 750, 1000, 2000, 3500
XORIGK M	-321.65	Reference grid coordinate of southwest corner of grid cell (1,1) X coordinate
YORIGK M	-272.07	Reference grid coordinate of southwest corner of grid cell (1,1) Y coordinate
RCUTR	30	Reference Cuticle Resistance
RGR	10	Reference Ground Resistance
REACTR	8	Reference Pollutant Reactivity
IVBG	1	Vegetation State In Unirrigated Areas
MOZ	1	Ozone Data Input Option ( 1= read hourly ozone concentration from the OZONE.DAT data file)
BCKO3	44	For O3 data missing
BCKNH3	2	Monthly ammonia concentrations
MHFTSZ	0	Switch For Using Heffter Equation For Sigma Z As Above
WSCALM	.5	Minimum Wind Speed (m/s) Allowed For Non-Calm Conditions
XMAXZI	3500 m	Maximum Mixing Height (m)
XMINZI	50 m	Minimum Mixing Height (m)

### 7.3.9 PSD Class I Increment Significance Analysis

CALMET/CALPUFF (Full CALPUFF) was used to model ambient air impacts of NO<sub>2</sub>, PM<sub>10</sub>, and SO<sub>2</sub> from the emission sources and the modeling results were compared to PSD Class I Increments modeling significance thresholds. The sources were modeled at full potential-to-emit (PTE) for this analysis. The full chemistry option of CALPUFF was turned on (MCHEM = 1, MESOPUFF II scheme), and a deposition option was turned on (MWET = 1 and MDRY = 1). 3-hour averaged SO<sub>2</sub> emission rates for all sources are same as 24-hour averaged SO<sub>2</sub> emission rates. Therefore, 24-hour averaged maximum SO<sub>2</sub> emission rate were modeled for 3-hour and 24-hour SO<sub>2</sub> increment analyses.

For 24-hour PM<sub>10</sub> increment analysis, the 24-hour averaged maximum PM<sub>10</sub> emission rate was modeled. The emission inventory for total PM was modeled as INCPM. The INCPM was treated as fine particulate matter in terms of geometric characteristics.

For the annual NO<sub>x</sub>, SO<sub>2</sub>, and PM<sub>10</sub> increment analyses, the annual emission rates estimated based on 8,760 hours of combination of normal operation and startup were used. For 24-hour and annual PM incremental analyses, the total PM emission ("INCPM" in the modeling) was modeled without speciation, and the INCPM was treated as fine particulate matter in terms of geometric characteristics.

### 7.3.10 Class I Area Visibility Reduction Analysis

Full CALPUFF was used to evaluate the potential for visibility reductions. All sources were modeled at full PTE for this analysis. Emissions of total SO<sub>2</sub> and PM<sub>10</sub> from the natural gas turbines were speciated based on National Park Service (NPS)'s Particulate Matter Speciation (PMS) guideline as described in Section 7.2.

The emissions of twelve chemical species, SO<sub>2</sub>, SO<sub>4</sub>, NO<sub>x</sub>, HNO<sub>3</sub>, NO<sub>3</sub>, PM<sub>0.05</sub>, PM<sub>0.01</sub>, PM<sub>0.15</sub>, PM<sub>0.20</sub>, PM<sub>0.25</sub>, PM<sub>1.0</sub>, EC and PM<sub>10</sub>, were modeled in CALPUFF to predict the visibility impact based on PMS for natural gas turbine. Because only SO<sub>2</sub> emissions estimates were provided, one-third of the estimated SO<sub>2</sub> emission was assumed to be SO<sub>4</sub> emissions, and the remaining two-thirds remained as SO<sub>2</sub> emissions. The total PM<sub>10</sub> emissions were speciated into Elemental Carbon (EC) and Secondary Organic Aerosol (SOA). The SOA is speciated again into PM<sub>0.05</sub>, PM<sub>0.01</sub>, PM<sub>0.15</sub>, PM<sub>0.20</sub>, PM<sub>0.25</sub>, and PM<sub>1.0</sub> (indicated as PM0005, PM0010, PM0015, PM0020, PM0025, and PM0100 in the modeling, respectively).

CALPOST was used to post process the modeled CALPUFF values. CALPOST was used to post-process the estimated 24-hour averaged ammonium nitrate, ammonium sulfate and PM concentrations into an extinction coefficient value for each day at each modeled receptor, using the three years of CALMET meteorological data. To do so, it required the use of extinction efficiency values.

All the PM species (PM<sub>0.05</sub>, PM<sub>0.01</sub>, PM<sub>0.15</sub>, PM<sub>0.20</sub>, PM<sub>0.25</sub>, and PM<sub>1.0</sub>) were grouped as PMF. The extinction efficiency of PMF was set as 4.0, which is equal to the extinction efficiency of SOA. Default extinction efficiencies of EC, soil, ammonium sulfate, and ammonium nitrate were used.

Background visibility and extinction coefficient values from the Federal Land Managers Air Quality Related Values Working Group (FLAG) Phase I Report (December 2000) were used for the visibility reduction analysis. Background values for hygroscopic concentration, without adjustment for relative humidity (RH), (0.6 µg/m<sup>3</sup>) and the non-hygroscopic concentration (4.5 µg/m<sup>3</sup>) are reported for western wilderness areas. Therefore, BKSO<sub>4</sub> = hygroscopic 0.6/3 = 0.2 and BKSOIL = non-hygroscopic = 4.5 were used. Modeled visibility reductions for each modeled year were compared to the level of acceptable change (LAC) of 5.0 percent.

### 7.3.11 Total Nitrogen and Sulfur Deposition Analyses

Full CALPUFF was used to evaluate the potential for nitrogen and sulfur deposition. All sources were modeled at full PTE for this analysis. The annual average emission rates were used for the annual averaged nitrogen and sulfur deposition analyses. The annual emission rates of all sources were estimated based on the combination of normal operation and startups. The annual emission rate was used for the annual NO<sub>x</sub>, annual SO<sub>2</sub>, and annual PM<sub>10</sub> impact analyses.

Since natural gas is the dominant fuel during the year, the total emissions of SO<sub>2</sub> and PM was speciated according to the NPS's PMS for natural gas combustion turbines. The emissions of twelve chemical species, SO<sub>2</sub>, SO<sub>4</sub>, NO<sub>x</sub>, HNO<sub>3</sub>, NO<sub>3</sub>, PM<sub>0.05</sub>, PM<sub>0.01</sub>, PM<sub>0.15</sub>, PM<sub>0.20</sub>, PM<sub>0.25</sub>, and PM<sub>1.0</sub>, EC, and PM<sub>10</sub>, were modeled in CALPUFF to predict the nitrogen and sulfur deposition.

The total deposition rates for each pollutant were obtained by summing the modeled wet and/or dry deposition rates as follows.

For S deposition, the wet and dry fluxes of sulfur dioxide and sulfate are calculated, normalized by the molecular weight of S, and expressed as total S. Total nitrogen deposition is the sum of N contributed by wet and dry fluxes of nitric acid (HNO<sub>3</sub>), nitrate (NO<sub>3</sub><sup>-</sup>), ammonium sulfate ((NH<sub>4</sub>)<sub>2</sub>SO<sub>4</sub>), and ammonium nitrate (NH<sub>4</sub>NO<sub>3</sub>) and the dry flux of nitrogen oxides (NO<sub>x</sub>).

Per WDEQ's "SEWY" CALPUFF input set up, 2 parts per billion of background NH<sub>3</sub> was used. The total modeled nitrogen and sulfur deposition rates were compared to the USNPS/USFWS DATs for western states. The DAT for nitrogen and sulfur are each 0.005 kilogram per hectare per year (kg/ha-yr), which is 1.59E-11 g/m<sup>2</sup>/s.

## 7.4 MODELING RESULTS

### 7.4.1 CALPUFF Modeling Results

Three years of CALPUFF modeling results of Phase II are provided in Table 7.9 through Table 7.11. The modeled criteria pollutant increment concentrations were compared to the Class I area Significant Impact Levels (SIL). All pollutant for all Class I areas and sensitive Class II area are in compliance with the increment analysis threshold, SIL.

Modeled visibility reductions for each modeled year were compared to the level of acceptable extinction change (LAC) of 5.0 % at each modeled area for each year. Since the sensitive Class II area, which is Savage Run, is the sensitive area for all three primary criteria pollutants such as NO<sub>x</sub>, SO<sub>2</sub>, and PM<sub>10</sub>, the visibility impact analysis was not applied to the sensitive Class II area.

None of the modeled results exceed the threshold values shown. The visibility impact is less than 5 percent and each criteria pollutant concentration is less than the corresponding threshold level. Deposition thresholds of total N and total S are both 0.005 kg/ha/yr, which is 1.59E-11 g/m<sup>2</sup>/s. Total N and S deposition impact do not exceeded the threshold.

None of the modeled results (criteria pollutant, deposition, visibility) exceeded the threshold. Therefore, no further analyses, including additional Air Quality Related Value (AQRV) impacts were conducted because the modeling results showed insignificant impact on air quality in the Class I and sensitive Class II areas.

### 7.4.2 Soil and Vegetation Analysis

Potential impact to soil and vegetation in Class I areas are evaluated on the basis of the model-predicted criteria pollutant concentrations, and the magnitude of predicted annual deposition of sulfur and nitrogen.

The predicted impacts are below significance levels and all threshold levels for soil and vegetation impact; therefore, the project can be expected to have negligible impacts.

**Table 7.9 – 2001 CALPUFF Modeling Results**

2001	Pollutant		Annual NO <sub>x</sub>	3-hr SO <sub>2</sub>	24-hr SO <sub>2</sub>	Annual SO <sub>2</sub>	24-hr PM	Annual PM	Deposition N	Deposition S	No. of Days >5%	Max Extinction Change
	Unit		µg/m <sup>3</sup>	µg/m <sup>3</sup>	µg/m <sup>3</sup>	µg/m <sup>3</sup>	µg/m <sup>3</sup>	Annual	g/m <sup>2</sup> /s	g/m <sup>2</sup> /s	Days	%
	Threshold		0.1	1	0.2	0.08	0.32	0.16	1.59E-11	1.59E-11	0	5
Class I Area	Bridger	BRID	1.57E-07	4.24E-04	9.19E-05	1.71E-06	5.61E-05	6.00E-07	3.62E-14	1.05E-14	0	0.28
	Eagles Nest	EANE	1.90E-05	2.06E-03	5.05E-04	7.02E-06	1.20E-04	1.77E-06	1.76E-13	6.12E-14	0	0.87
	Fitzpatrick	FITZ	2.38E-08	6.60E-04	1.23E-04	6.64E-07	4.53E-05	1.66E-07	5.95E-15	2.43E-15	0	0.17
	Flat Tops	FLTO	1.66E-05	1.31E-03	3.86E-04	7.29E-06	1.57E-04	1.94E-06	2.18E-13	5.34E-14	0	0.99
	Maroon Bell Snow	MABE	3.48E-06	9.24E-04	1.71E-04	2.09E-06	5.90E-05	5.04E-07	1.61E-13	3.74E-14	0	0.14
	Mount Zirkel	MOZI	1.98E-04	9.31E-03	3.50E-03	3.64E-05	2.31E-03	2.58E-05	4.71E-13	1.63E-13	0	2.96
	Rawah	RAWA	2.86E-04	1.32E-02	5.14E-03	5.19E-05	5.07E-03	5.51E-05	6.29E-13	2.14E-13	0	4.67
Rocky Mountain	ROMO	1.36E-04	6.10E-03	2.99E-03	3.82E-05	2.33E-03	2.75E-05	4.23E-13	1.74E-13	0	1.96	
Sensitive Class II Area	Savage Run	SAVA	3.68E-04	2.39E-02	6.56E-03	7.80E-05	6.12E-03	9.29E-05	1.24E-12	4.51E-13	0	4.73
Exceed?			No	No	No	No	No	No	No	No	No	No

**Table 7-10 – 2002 CALPUFF Modeling Results**

2002	Pollutant		Annual NO <sub>x</sub>	3-hr SO <sub>2</sub>	24-hr SO <sub>2</sub>	Annual SO <sub>2</sub>	24-hr PM	Annual PM	Deposition N	Deposition S	No. of Days >5%	Max Extinction Change
	Unit		µg/m <sup>3</sup>	µg/m <sup>3</sup>	µg/m <sup>3</sup>	µg/m <sup>3</sup>	µg/m <sup>3</sup>	Annual	g/m <sup>2</sup> /s	g/m <sup>2</sup> /s	Days	%
	Threshold		0.1	1	0.2	0.08	0.32	0.16	1.59E-11	1.59E-11	0	5
Class I Area	Bridger	BRID	9.83E-06	2.87E-03	3.76E-04	9.98E-06	4.50E-04	5.50E-06	2.17E-13	9.94E-14	0	0.19
	Eagles Nest	EANE	6.31E-06	1.02E-03	2.87E-04	6.27E-06	1.51E-04	3.57E-06	6.72E-14	2.58E-14	0	0.46
	Fitzpatrick	FITZ	2.38E-06	7.71E-04	2.40E-04	4.04E-06	1.80E-04	2.39E-06	7.86E-14	3.43E-14	0	0.15
	Flat Tops	FLTO	1.28E-05	1.37E-03	4.31E-04	9.82E-06	4.12E-04	6.59E-06	8.96E-14	3.40E-14	0	1.06
	Maroon Bell Snow	MABB	4.68E-06	1.66E-03	3.38E-04	3.19E-06	1.81E-04	2.19E-06	6.44E-14	1.96E-14	0	0.65
	Mount Zirkel	MOZI	7.31E-05	5.74E-03	1.92E-03	3.47E-05	2.18E-03	2.71E-05	2.44E-13	1.10E-13	0	1.41
	Rawah	RAWA	2.53E-04	1.11E-02	2.15E-03	7.06E-05	3.72E-03	5.29E-05	8.73E-13	3.33E-13	0	3.65
	Rocky Mountain	ROMO	1.22E-04	5.23E-03	1.28E-03	3.78E-05	1.24E-03	1.89E-05	6.99E-13	2.60E-13	0	1.78
Sensitive Class II Area	Savage Run	SAVA	2.92E-04	1.50E-02	3.96E-03	9.65E-05	6.33E-03	1.02E-04	8.37E-13	3.54E-13	0	2.87
Exceed?			No	No	No	No	No	No	No	No	No	No



**Table 7-11 - 2003 CALPUFF Modeling Results**

2003	Pollutant		Annual NO <sub>x</sub>	3-hr SO <sub>2</sub>	24-hr SO <sub>2</sub>	Annual SO <sub>2</sub>	24-hr PM	Annual PM	Deposition N	Deposition S	No. of Days >5%	Max Extinction Change
	Unit		µg/m <sup>3</sup>	µg/m <sup>3</sup>	µg/m <sup>3</sup>	µg/m <sup>3</sup>	µg/m <sup>3</sup>	Annual	g/m <sup>2</sup> /s	g/m <sup>2</sup> /s	Days	%
	Threshold		0.1	1	0.2	0.08	0.32	0.16	1.59E-11	1.59E-11	0	5
Class I Area	Bridger	BRID	5.21E-07	4.77E-04	1.25E-04	2.15E-06	4.05E-05	6.59E-07	8.20E-14	4.25E-14	0	0.08
	Eagles Nest	EANE	1.57E-05	1.96E-03	3.50E-04	7.34E-06	2.43E-04	3.97E-06	1.92E-13	6.62E-14	0	0.38
	Fitzpatrick	FITZ	2.95E-08	1.39E-04	6.09E-05	5.95E-07	2.75E-05	2.02E-07	3.37E-14	2.07E-14	0	0.03
	Flat Tops	FLTO	3.82E-05	4.68E-03	1.06E-03	1.46E-05	5.58E-04	8.47E-06	2.15E-13	9.21E-14	0	0.55
	Maroon Bell Snow	MABE	5.00E-06	1.21E-03	2.26E-04	3.71E-06	1.68E-04	2.15E-06	1.32E-13	5.22E-14	0	0.41
	Mount Zirkel	MOZI	3.71E-04	9.23E-03	2.80E-03	5.47E-05	5.09E-03	6.88E-05	1.26E-12	3.96E-13	0	1.45
	Rawah	RAWA	2.60E-04	1.30E-02	3.21E-03	7.55E-05	2.26E-03	5.39E-05	9.17E-13	3.54E-13	0	2.19
Rocky Mountain	ROMO	1.33E-04	4.65E-03	1.65E-03	4.21E-05	9.70E-04	2.95E-05	7.16E-13	2.93E-13	0	0.96	
Sensitive Class II Area	Savage Run	SAVA	6.72E-04	1.95E-02	5.56E-03	1.20E-04	6.49E-03	1.43E-04	2.04E-12	6.86E-13	0	4.17
Exceed?			No	No	No	No	No	No	No	No	No	No

**7.5 CONCLUSION**

Conservatively modeling the proposed Medicine Bow emissions in CALPUFF resulted in modeled concentrations below the Class I Area threshold levels for deposition, significant impact, and visibility. Therefore, the proposed Medicine Bow sources will not have a significant impact on ambient air quality of Class I areas.

Since there were no significant increment, visibility impacts, or soil and vegetation on Class I areas, it was concluded that no further impacts would be likely and, and therefore no additional Air Quality Related Value (AQRV) impact analyses were conducted

**Appendix A**

**Wyoming Permit Application Form**



DEPARTMENT OF ENVIRONMENTAL QUALITY  
AIR QUALITY DIVISION

PERMIT APPLICATION FORM

Date of Application December 31, 2007

1. Name of Firm or Institution: Medicine Bow Fuel & Power LLC

2. Mailing Address

<u>2 Riverway, Suite 1780</u>	<u>Houston</u>	<u>TX</u>
Number Street	City	State
<u>77056</u>	<u>713-425-6520</u>	
County Zip	Telephone	

3. Plant Location

<u>7.5 miles north of I-80, Exit 260</u>	<u>near Medicine Bow</u>	<u>WY</u>
Number Street	City	State
<u>Carbon</u>	<u>82329</u>	
County Zip	Telephone	

Section 29, Township 21 North, Range 79 West

4. Name of owner or company official to contact regarding air pollution matters

<u>Tim Stamp</u>	<u>Site Contact</u>	<u>(307) 340-1978</u>
Name	Title	Telephone
<u>1620 Central Avenue</u>	<u>Chevenne</u>	<u>WY 82001</u>
Number Street	City	State Zip

5. General nature of business

Hydrocarbon conversion through gasification & liquefaction technologies. Support activities include coal mining and electrical generation (no electricity export).

6. Permit application is made for:  X  New Construction   Modification  
  Relocation   Operation

7. Type of equipment to be constructed, modified, or relocated. (List each major piece of equipment separately.)

Refer to Table 3.2 of the application document for a list of major equipment with point source emissions. A list of all major equipment (with and without point source emissions) is provided in Appendix D of the application document.

8. If application is being made for operation of an existing source in a new location, list previous location and new location:

Previous Location:  NA

New Location:  NA

9. If application is being made for a crushing unit, is there: (mark all appropriate boxes)

Primary Crushing  Control Equipment:  Enclosed crushers, coal mixed with water, fogging

Secondary Crushing Control Equipment:  N/A

Tertiary Crushing Control Equipment:  N/A

Recrushing & Screening Control Equipment:  N/A

Conveying  Control Equipment:  Enclosed conveyors, fogging system

Drying Control Equipment:  N/A

Other Control Equipment:  N/A

Proposed dates of operation (month/year)  Facility startup December 2010; equipment to operate year-round.

10. Materials used in unit or process (include solid fuels):

Type of Material	Process Weight Average (lb/hr)	Process Weight Maximum (lb/hr)	Quantity/Year
Coal	666,600 (dry)	666,600 (dry)	3,200,000 ton/year

11. Air contaminants emitted:

Emission Point	Pollutant	[lb/hr]	[ton/yr]	Basis of Data
Refer to Section 3.0 and Appendix B of the application document.				

12. Air contaminant control equipment:

Emission Point	Type	Pollutant Removed	Efficiency
Active Coal Storage	Stacking Tubes	PM	See Note 1
Coal Handling	Enclosed conveyors; Fogger & Passive Engineering Design at transfer points	PM	See Note 1
Combustion Turbines (3, total)	Low NOx burner, SCR, oxidation catalyst	NOx, CO, VOC	See Note 1
Process Heaters (3, total) Auxiliary Boiler (1, total)	Low NOx burner	NOx	See Note 1
Storage Tanks	Internal Floating Roof (IFR)	VOC, HAPs	See Note 1
Startup/Shutdown/Malfunions	Flares (2, total)	VOC, HAPs, H <sub>2</sub> S	98%

Notes for Item #12:

1. Refer to Section 3.0 (Emission Estimates), 4.0 (BACT Analysis), and Appendix B (Emission Calculations) of application document for control equipment efficiencies.

## Combustion Turbines (Electricity Generation)

13. Type of combustion unit: (check if applicable)

A. Coal \_\_\_\_\_

1. Pulverized :

General \_\_\_\_\_; Dry Bottom \_\_\_\_\_; Wet Bottom \_\_\_\_\_; With Flyash Reinjection \_\_\_\_\_;  
Without Flyash Reinjection \_\_\_\_\_; Other \_\_\_\_\_

2. Spreader Stoker :

With Flyash Reinjection \_\_\_\_\_; Without Flyash Reinjection \_\_\_\_\_; Cyclone \_\_\_\_\_;  
Hand-Fired \_\_\_\_\_; Other \_\_\_\_\_

B. Fuel Oil

Horizontally Fired \_\_\_\_\_; Tangentially Fired \_\_\_\_\_

C. Natural Gas X (startup and as supplement during normal operations) ;

D. If other, please specify Fuel Gas Mixture

Hourly fuel consumption (estimate for new equipment): \_\_\_\_\_

Size of combustion unit: 660-786 MMBtu/hr

14. Operating Schedule: 24 hours/day; 7 days/week; 52 weeks/year

Peak production season (if any): NA

Refer to Section 3 and Appendix B of the application document for details on fuel fired and amounts fired.

15. Fuel analysis:

	FUEL GAS MXTURE	NATURAL GAS
% Sulfur	0.1 ppmv	2.9 ppmv (2,000 gr/MMscf)
% Ash	0	0
BTU Value		1,020 Btu/scf assumed

## Auxiliary Boiler

13. Type of combustion unit: (check if applicable)

A. Coal \_\_\_\_\_

1. Pulverized :

General \_\_\_\_\_; Dry Bottom \_\_\_\_\_; Wet Bottom \_\_\_\_\_; With Flyash Reinjection \_\_\_\_\_;  
Without Flyash Reinjection \_\_\_\_\_; Other \_\_\_\_\_

2. Spreader Stoker :

With Flyash Reinjection \_\_\_\_\_; Without Flyash Reinjection \_\_\_\_\_; Cyclone \_\_\_\_\_;  
Hand-Fired \_\_\_\_\_; Other \_\_\_\_\_

B. Fuel Oil

Horizontally Fired \_\_\_\_\_; Tangentially Fired \_\_\_\_\_

C. Natural Gas X (startup and as supplement during normal operations) ;

D. If other, please specify Fuel Gas Mixture \_\_\_\_\_

Hourly fuel consumption (estimate for new equipment): \_\_\_\_\_

**Refer to Section 3 and Appendix B of the application document for details on fuel fired and amounts fired.**

Size of combustion unit: \_\_\_\_\_ 66 MM BTU heat input/hour

14. Operating Schedule: Full load for 760 hr/yr and 25% load for 8000 hr/yr

Peak production season (if any): NA

15. Fuel analysis:

	FUEL GAS MXTURE	NATURAL GAS
% Sulfur	0.1 ppmv	2.9 ppmv (2,000 gr/MMscf)
% Ash	0	0
BTU Value		1,020 Btu/scf assumed



### Catalyst Regeneration Heater (B-1)

13. Type of combustion unit: (check if applicable)

A. Coal \_\_\_\_\_

1. Pulverized :

General \_\_\_\_\_; Dry Bottom \_\_\_\_\_; Wet Bottom \_\_\_\_\_; With Flyash Reinjection \_\_\_\_\_;  
Without Flyash Reinjection \_\_\_\_\_; Other \_\_\_\_\_

2. Spreader Stoker :

With Flyash Reinjection \_\_\_\_\_; Without Flyash Reinjection \_\_\_\_\_; Cyclone \_\_\_\_\_;  
Hand-Fired \_\_\_\_\_; Other \_\_\_\_\_

B. Fuel Oil

Horizontally Fired \_\_\_\_\_; Tangentially Fired \_\_\_\_\_

C. Natural Gas  X (startup and as supplement during normal operations) ;

D. If other, please specify  during times of normal operation in standby, the fuel will be a Fuel Gas Mixture, mixed with Natural Gas

Refer to Section 3 and Appendix B of the application document for details on fuel fired and amounts fired.

Hourly fuel consumption (estimate for new equipment): \_\_\_\_\_

Refer to Section 3 and Appendix B of the application document for details on fuel fired and amounts fired.

Size of combustion unit: \_\_\_\_\_ 21.53 MM BTU heat input/hour

14. Operating Schedule:  @21.53 MMBtu/hr for 877 hr/yr and @ 3.58 MMBtu/hr for 7123 hr/yr

Peak production season (if any):  NA

15. Fuel analysis:

	FUEL GAS MIXTURE	NATURAL GAS
% Sulfur	0.1 ppmv	2.9 ppmv (2,000 gr/MMscf)
% Ash	0	0
BTU Value		1,020 Btu/scf assumed

## Reactivation Heater (B-2)

13. Type of combustion unit: (check if applicable)

A. Coal \_\_\_\_\_

1. Pulverized:

General \_\_\_\_\_; Dry Bottom \_\_\_\_\_; Wet Bottom \_\_\_\_\_; With Flyash Reinjection \_\_\_\_\_;  
Without Flyash Reinjection \_\_\_\_\_; Other \_\_\_\_\_

2. Spreader Stoker:

With Flyash Reinjection \_\_\_\_\_; Without Flyash Reinjection \_\_\_\_\_; Cyclone \_\_\_\_\_;  
Hand-Fired \_\_\_\_\_; Other \_\_\_\_\_

B. Fuel Oil

Horizontally Fired \_\_\_\_\_; Tangentially Fired \_\_\_\_\_

C. Natural Gas X (startup and as supplement during normal operations);

D. If other, please specify Fuel Gas Mixture

Hourly fuel consumption (estimate for new equipment): \_\_\_\_\_

**Refer to Section 3 and Appendix B of the application document for details on fuel fired and amounts fired.**

Size of combustion unit: \_\_\_\_\_ 12.45 MM BTU heat input/hour

14. Operating Schedule: \_\_\_\_\_ 2,216 hours/year

Peak production season (if any): NA

15. Fuel analysis:

	FUEL GAS MXTURE	NATURAL GAS
% Sulfur	0.1 ppmv	2.9 ppmv (2,000 gr/MMscf)
% Ash	0	0
BTU Value		1,020 Btu/scf assumed

### HGT Reactor Charge Heater (B-3)

13. Type of combustion unit: (check if applicable)

A. Coal \_\_\_\_\_

1. Pulverized :

General \_\_\_\_\_; Dry Bottom \_\_\_\_\_; Wet Bottom \_\_\_\_\_; With Flyash Reinjection \_\_\_\_\_;  
Without Flyash Reinjection \_\_\_\_\_; Other \_\_\_\_\_

2. Spreader Stoker :

With Flyash Reinjection \_\_\_\_\_; Without Flyash Reinjection \_\_\_\_\_; Cyclone \_\_\_\_\_;  
Hand-Fired \_\_\_\_\_; Other \_\_\_\_\_

B. Fuel Oil

Horizontally Fired \_\_\_\_\_; Tangentially Fired \_\_\_\_\_

C. Natural Gas  X (startup and as supplement during normal operations) ;

D. If other, please specify  Fuel Gas Mixture

Hourly fuel consumption (estimate for new equipment): \_\_\_\_\_

**Refer to Section 3 and Appendix B of the application document for details on fuel fired and amounts fired.**

Size of combustion unit: \_\_\_\_\_  2.22 MM BTU heat input/hour

14. Operating Schedule:  24  hours/day;  7  days/week;  52  weeks/year

Peak production season (if any):  NA

15. Fuel analysis:

	FUEL GAS MIXTURE	NATURAL GAS
% Sulfur	0.1 ppmv	2.9 ppmv (2,000 gr/MMscf)
% Ash	0	0
BTU Value		1,020 Btu/scf assumed

**Gasifier Preheaters (5 total, for cold startup only)**

13. Type of combustion unit: (check if applicable)

A. Coal \_\_\_\_\_

1. Pulverized :

General \_\_\_\_\_ ; Dry Bottom \_\_\_\_\_ ; Wet Bottom \_\_\_\_\_ ; With Flyash Reinjection \_\_\_\_\_ ;  
Without Flyash Reinjection \_\_\_\_\_ ; Other \_\_\_\_\_

2. Spreader Stoker :

With Flyash Reinjection \_\_\_\_\_ ; Without Flyash Reinjection \_\_\_\_\_ ; Cyclone \_\_\_\_\_ ;  
Hand-Fired \_\_\_\_\_ ; Other \_\_\_\_\_

B. Fuel Oil

Horizontally Fired \_\_\_\_\_ ; Tangentially Fired \_\_\_\_\_

C. Natural Gas X ;

D. If other, please specify \_\_\_\_\_

Hourly fuel consumption (estimate for new equipment): \_\_\_\_\_

Refer to Section 3 and Appendix B of the application document for details on fuel consumption.

Size of combustion unit: \_\_\_\_\_ 21 MM BTU heat input/hour

14. Operating Schedule: As needed during normal operation

Peak production season (if any): 500 hr/yr (each) during cold startup, as needed during normal operation

15. Fuel analysis:

	COAL	FUEL OIL	NATURAL GAS
% Sulfur			2.9 ppmv (2,000 gr/MMscf)
% Ash			0
BTU Value			1,020 Btu/scf assumed

**Black Start Generators (3, total)**

13. Type of combustion unit: (check if applicable)

A. Coal \_\_\_\_\_

1. Pulverized :

General \_\_\_\_\_; Dry Bottom \_\_\_\_\_; Wet Bottom \_\_\_\_\_; With Flyash Reinjection \_\_\_\_\_;  
Without Flyash Reinjection \_\_\_\_\_; Other \_\_\_\_\_

2. Spreader Stoker :

With Flyash Reinjection \_\_\_\_\_; Without Flyash Reinjection \_\_\_\_\_; Cyclone \_\_\_\_\_;  
Hand-Fired \_\_\_\_\_; Other \_\_\_\_\_

B. Fuel Oil

Horizontally Fired \_\_\_\_\_; Tangentially Fired \_\_\_\_\_

C. Natural Gas X ;

D. If other, please specify \_\_\_\_\_

Hourly fuel consumption (estimate for new equipment): \_\_\_\_\_

Size of combustion unit: \_\_\_\_\_ **19.5 MM BTU** heat input/hour  
(assuming 2,889 bhp, 6,748 Btu/hp-hr)

14. Operating Schedule: As needed during normal operation

Peak production season (if any): Up to 250 hr/yr. each during cold startup

15. Fuel analysis:

	COAL	FUEL OIL	NATURAL GAS
% Sulfur			2.9 ppmv (2,000 gr/MMscf)
% Ash			0
BTU Value			1,020 Btu/scf assumed

16. Products of process or unit:

Products	Quantity/Year
Gasoline (varying RVP, by season)	6.75 million barrels
Sulfur	15,330 tons
CO <sub>2</sub>	4.12 million tons
Slag	0.26 million tons

17. Emissions to the atmosphere (each point of emission should be listed separately and numbered so that it can be located on the flow sheet):

Emission Point	Description	Stack Height (ft)	Stack Diameter (ft)	Gas Discharge (ACFM)	Exit Temp (°F)	Gas Velocity (ft/s)
<i>Refer to Section 6.2.2, Table 6.2 of the application document for a list of emission points.</i>						

18. Does the input material or product from this process or unit contain finely divided materials which could become airborne?

Yes                       No

Is this material stored in piles or in some other way as to make possible the creation of dust problems?

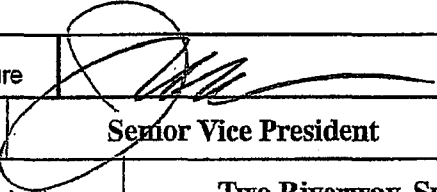
Yes                       No

List storage pile (if any):

Type of Material	Particle Size (Diameter or Screen Size)	Pile Size (Avg Tons on Pile)	Pile Wetted (Yes or No)	Pile Covered (Yes or No)
Coal - Active Coal Stockpile	12" minus	300,000	No	Partially sheltered by earth berms
Coal - Emergency Coal Stockpile	4" minus	300,000	Compacted & Sealed	
Slag Pile	2" minus	30,000	Yes (water)	No

19. Using a flow diagram:
- (1) Illustrate input of raw materials. Refer to Figures 2.1 and 2.2.
  - (2) Label production processes, process fuel combustion, process equipment, and air pollution control equipment. Refer to Figures 2.1 and 2.2.
  - (3) Illustrate locations of air contaminant release so that emission points under items 11, 12 and 17 can be identified. For refineries show normal pressure relief and venting systems. Attach extra pages as needed. Refer to Figures 1.3 and 1.4.
20. A site map should be included indicating the layout of facility at the site. All buildings, pieces of equipment, roads, pits, rivers and other such items should be shown on the layout. Refer to Figures 1.1, 1.2, and 1.3.
21. A location drawing should be included indicating location of the facility with respect to prominent highways, cities, towns, or other facilities (include UTM coordinates). Refer to Figure 1.1.

"I certify to the accuracy of the plans, specifications, and supplementary data submitted with this application. It is my Opinion that any new equipment installed in accordance with these submitted plans and operated in accordance with the manufacturer's recommendations will meet emission limitations specified in the Wyoming Air Quality Standards and Regulations."

Signature		Typed Name	<b>Jude R. Rolfes</b>		
Title	<b>Senior Vice President</b>	Company	<b>Medicine Bow Fuel &amp; Power LLC</b>		
Mailing Address	<b>Two Riverway, Suite 1780</b>		Telephone No.	<b>(713) 425-6526</b>	
City	<b>Houston</b>	State	<b>Texas</b>	Zip	<b>77056</b>
P.E. Registration (if applicable)	<b>016517</b>				
State where registered	<b>VA</b>				



**Appendix B**  
**Emission Calculations**

Medicine Bow Fuel & Power Industrial Gasification & Liquefaction Plant  
Emission Summary Sheet

Normal Operations (8760 hr/yr)

ID No.	Description	Usage	Operation (hr/yr)	Potential Emissions (tpy)					HAPs Emissions (tpy)																			
				NO <sub>x</sub>	CO	VOC	SO <sub>2</sub>	PM <sub>10</sub>	1,3-Butadiene	Acetaldehyde	Acrolein	2,2,4-Trimethylpentane	Benzene	Carbonyl Sulfide	Dichlorobenzene	Ethyl Benzene	Formaldehyde	Hexane	Mercury	Methanol	Naphthalene	PHH	Propylene Oxide	Toluene	Xylene	TOTALS		
GT-1	Turbine and HRSG Train 1	General Electric, 66 MW	8760	74.88	46.19	6.59	10.78	43.80	1.37E-03	1.27E-01	2.03E-02		3.81E-02			1.02E-01	2.26E-01		1.23E-04		4.13E-03	6.98E-03	0.21E-02	4.13E-01	2.03E-01	1.23E+00		
GT-2	Turbine and HRSG Train 2	General Electric, 66 MW	8760	74.88	46.19	6.59	10.78	43.80	1.37E-03	1.27E-01	2.03E-02		3.81E-02			1.02E-01	2.26E-01		1.23E-04		4.13E-03	6.98E-03	0.21E-02	4.13E-01	2.03E-01	1.23E+00		
GT-3	Turbine and HRSG Train 3	General Electric, 66 MW	8760	76.80	48.19	6.59	10.78	43.80	1.37E-03	1.27E-01	2.03E-02		3.81E-02			1.02E-01	2.26E-01		1.23E-04		4.13E-03	6.98E-03	0.21E-02	4.13E-01	2.03E-01	1.23E+00		
A0	Auxiliary Boiler	Heater, 80 MMlb/hr	8760	2.80	2.68	0.23	0.04	0.36					1.87E-04		1.07E-04	6.69E-03	1.01E-01				5.44E-05			3.03E-04		1.68E-01		
B-1	Catalyst Regenerator	Heater, 21.63 MMlb/hr	8009	0.82	2.30	0.15	0.02	0.21					5.76E-05		3.29E-05	2.06E-03	4.93E-02				9.81E-06			0.32E-05		6.46E-02		
B-2	Desulfurization Heater	Heater, 12 MMlb/hr	1459	0.33	0.94	0.33	0.01	0.00					2.34E-05		1.34E-05	8.37E-04	2.91E-02				8.81E-06			3.10E-05		2.10E-02		
B-3	HOT Reactor Charge Heater	Heater, 2 MMlb/hr	8760	0.85	1.86	0.07	0.01	0.09					1.42E-05		8.90E-04	2.12E-02	7.24E-06				4.03E-05			3.23E-07		2.23E-02		
Tanks	Storage Tanks	Product Storage	8760			102.82							6.27E-01		3.79E-02	4.95E-01		2.30E+00					5.87E-01	1.80E-01	4.17E+00			
EL	Equipment Leaks	Fugitives	8760			71.32							1.04E+01	2.90E-01				1.04E+01							2.11E+01			
OB	Coal Storage	Fugitives	8760					60.18																	0.00E+00			
FW Pump	Firewater Pump <sup>1</sup>	Engine, 675 HP	500	1.51	0.09	0.34	1.52E-03	0.02					3.77E-05	7.39E-04	8.91E-05								8.17E-05		2.49E-03	3.04E-04	2.76E-04	6.44E-03
FL-1	HP / Emergency Flare <sup>2</sup>	Flare, 0.819 MMlb/hr	8760	0.40	0.58	2.97	2.10E-03						8.99E-04			1.14E-03										0.00E+00		
FL-2	LP Flare <sup>2</sup>	Flare, 0.204 MMlb/hr	8760	0.12	0.25	0.74	0.00																			0.00E+00		
<b>Total Emissions</b>				<b>233.00</b>	<b>146.89</b>	<b>198.33</b>	<b>32.40</b>	<b>102.24</b>	<b>4.13E-03</b>	<b>3.82E-01</b>	<b>6.10E-02</b>	<b>9.01E+00</b>	<b>1.11E+01</b>	<b>2.80E-01</b>	<b>1.04E-03</b>	<b>3.43E-01</b>	<b>7.08E-01</b>	<b>7.29E-01</b>	<b>3.70E-04</b>	<b>1.28E+01</b>	<b>1.26E-02</b>	<b>2.10E-02</b>	<b>2.79E-01</b>	<b>1.81E+00</b>	<b>7.78E-01</b>	<b>25.24</b>		

Notes:  
<sup>1</sup> SO<sub>2</sub> emissions from the Firewater Pump are not based on burning ultra-low sulfur diesel (15 ppm).  
<sup>2</sup> Flare emissions include pilot emissions for 8760 hr/yr.

Malfunctions and Other Events

ID No.	Description	Usage	Operation (hours)	Potential Emissions (tons)					HAPs Emissions (tpy)																	
				NO <sub>x</sub>	CO	VOC	SO <sub>2</sub>	PM <sub>10</sub>	1,3-Butadiene	Acetaldehyde	Acrolein	2,2,4-Trimethylpentane	Benzene	Carbonyl Sulfide	Dichlorobenzene	Ethyl Benzene	Formaldehyde	Hexane	Mercury	Methanol	Naphthalene	Propylene Oxide	Toluene	Xylene	TOTALS	
CO2 VS	CO2 Vent Stack	CO2 Vent Stack	60		73.30	0.01																				0.00E+00
FL-1	HP / Emergency Flare	Flare, 0.819 MMlb/hr	40	7.83	84.99	0.12	150.18																			0.00E+00
FL-2	LP Flare	Flare, 0.204 MMlb/hr	8	1.16E-02	2.25E-04	6.79E-04	14.40																			0.00E+00
GP-1	Gasification Preheater	Heater, 21.00 MMlb/hr	600	0.28	0.43	0.02	3.00E-03	0.04					1.08E-05	0.16E-00		3.80E-04	3.20E-03									1.75E-03

Notes:  
<sup>1</sup> The hours shown are annual estimates, except for the Gasification Preheater which is based on 500 hours per preheating event for one gasifier.

Medicine Bow Fuel & Power Industrial Gasification & Liquefaction Plant  
Emission Summary Sheet

Initial Year Including Cold Startup Emissions

This sheet includes initial emissions from a cold startup (second set of emissions) and from the remainder of the initial year of operations. The total emissions shown at the bottom of this sheet provide the total emissions for the initial year (or any year with a cold startup).

Normal Operations (After Startup)

ID No.	Description	Usage	Normal Operating Hours After Startup (hr/yr)	Potential Emissions (t/yr)					HAPs Emissions (t/yr)														TOTALS					
				NO <sub>x</sub>	CO	VOC	SO <sub>2</sub>	PM <sub>10</sub>	1,2-Dichlorobenzene	Acealdehyde	Acrolein	2,2,4-Trimethylpentane	Benzene	Carbonyl Sulfide	Dichlorobenzene	Ethyl Benzene	Formaldehyde	Hexane	Mercury	Methanol	Naphthalene	PAH		Propylene Oxide	Toluene	Xylene		
GT-1	Turbine and HRSG Train 1	General Electric, 68 MW	7,760	67.20	40.92	5.84	9.58	38.80	1.21E-03	1.12E-01	1.80E-02	3.37E-02	8.00E-02	2.00E-01	1.09E-04	3.88E-03	6.19E-03	6.18E-02	3.66E-01	1.80E-01	1.09E-01	1.09E-01	1.09E-01	1.09E-01	1.09E-01			
GT-2	Turbine and HRSG Train 2	General Electric, 68 MW	7,760	67.20	40.92	5.84	9.58	38.80	1.21E-03	1.12E-01	1.80E-02	3.37E-02	8.00E-02	2.00E-01	1.09E-04	3.88E-03	6.19E-03	6.18E-02	3.66E-01	1.80E-01	1.09E-01	1.09E-01	1.09E-01	1.09E-01	1.09E-01			
GT-3	Turbine and HRSG Train 3	General Electric, 68 MW	7,760	67.20	40.92	5.84	9.58	38.80	1.21E-03	1.12E-01	1.80E-02	3.37E-02	8.00E-02	2.00E-01	1.09E-04	3.88E-03	6.19E-03	6.18E-02	3.66E-01	1.80E-01	1.09E-01	1.09E-01	1.09E-01	1.09E-01	1.09E-01			
AD	Auxiliary Boiler	Heater, 66 MMBtu/hr	8,000	2.38	2.44	0.26	0.04	0.33				1.71E-04			9.78E-05				6.11E-03	1.47E-01				4.97E-05	2.77E-04	1.53E-01		
B-1	Catalyst Regenerator	Heater, 21.53 MMBtu/hr	8,000	0.82	2.30	0.16	0.02	0.21				5.76E-05			3.28E-05				8.07E-03	4.93E-02				9.61E-06	9.32E-05	5.18E-02		
B-2	Reaction Heater	Heater, 12 MMBtu/hr	1,458	0.33	0.94	0.08	0.01	0.08				2.34E-05			1.34E-05				8.37E-04	2.01E-02				8.61E-06	3.79E-05	2.10E-02		
B-3	HGT Reactor Charge Heater	Heater, 2 MMBtu/hr	8,000	0.33	0.91	0.06	0.01	0.08				1.30E-05			6.13E-04				1.95E-02	6.61E-03				3.68E-05	2.35E-07	2.04E-02		
Tanks	Storage Tanks	Product Storage	8,000				102.82					6.27E-01							3.70E-02	4.92E-01				2.31E+00	5.07E-01	1.60E-01	4.17E+00	
EL	Equipment Leaks	Fugitives	8780				71.32					1.04E+01	2.60E-01												1.04E+01	0.00E+00		
CS	Coal Storage	Fugitives	8780					60.18																		60.18E+00	0.00E+00	
FW-Pump	Fluorator Pump <sup>1</sup>	Engine, 575 HP	600	1.51	0.09	0.31	1.62E-03	0.02	3.77E-05	1.38E-04	8.81E-05	0.99E-04			1.14E-03									8.17E-05	2.48E-03	3.04E-04	2.75E-04	0.14E-03
FL-1	HP / Emergency Flare <sup>2</sup>	Flare Pilot, 0.816 MMBtu/hr	8780	0.49	0.98	2.97	2.10E-03																				0.00E+00	
FL-2	LP Flare <sup>2</sup>	Flare Pilot, 0.204 MMBtu/hr	8780	0.12	0.25	0.74	0.00																				0.00E+00	
Total Emissions (Partial Year of Normal Operations)				207.57	139.88	198.04	28.78	177.30	3.87E-03	3.38E-01	8.41E-02	0.00E+00	1.11E-01	2.60E-01	9.57E-04	3.08E-01	0.29E-01	7.11E-01	3.28E-04	1.28E+01	1.12E-02	1.88E-02	2.47E-01	1.67E+00	7.09E-01	28.80		

Notes:  
<sup>1</sup> CO<sub>2</sub> emissions from the Fluorator Pump are based on burning ultra-low sulfur diesel (15 ppm).  
<sup>2</sup> Flare emissions include pilot emissions for 8780 hr/yr.

Cold Startup

ID No.	Description	Usage	Startup Operating Hours (hr/yr)	Potential Emissions (t/yr)					HAPs Emissions (t/yr)														TOTALS				
				NO <sub>x</sub>	CO	VOC	SO <sub>2</sub>	PM <sub>10</sub>	1,2-Dichlorobenzene	Acealdehyde	Acrolein	2,2,4-Trimethylpentane	Benzene	Carbonyl Sulfide	Dichlorobenzene	Ethyl Benzene	Formaldehyde	Hexane	Mercury	Methanol	Naphthalene	PAH		Propylene Oxide	Toluene	Xylene	
GT-1	Turbine and HRSG Train 1	General Electric, 68 MW	1,000	9.48	5.89	0.81	1.33	5.00	1.89E-04	1.67E-02	2.51E-03	4.71E-03	1.28E-02	2.78E-02	1.82E-05	6.10E-04	8.64E-04	1.14E-02	6.10E-02	2.61E-02	1.52E-01	1.52E-01	1.52E-01	1.52E-01	1.52E-01	1.52E-01	
GT-2	Turbine and HRSG Train 2	General Electric, 68 MW	1,000	9.48	5.89	0.81	1.33	5.00	1.89E-04	1.67E-02	2.51E-03	4.71E-03	1.28E-02	2.78E-02	1.82E-05	6.10E-04	8.64E-04	1.14E-02	6.10E-02	2.61E-02	1.52E-01	1.52E-01	1.52E-01	1.52E-01	1.52E-01	1.52E-01	
GT-3	Turbine and HRSG Train 3	General Electric, 68 MW	1,000	9.48	5.89	0.81	1.33	5.00	1.89E-04	1.67E-02	2.51E-03	4.71E-03	1.28E-02	2.78E-02	1.82E-05	6.10E-04	8.64E-04	1.14E-02	6.10E-02	2.61E-02	1.52E-01	1.52E-01	1.52E-01	1.52E-01	1.52E-01	1.52E-01	
Gen-1	Black-Start Generator	Caterpillar, 2889 HP	250	0.80	1.93	0.72	1.43E-03	1.88E-04	6.61E-04	2.04E-02	1.28E-02	0.09E-04	5.17E-04	1.29E-01	2.70E-04										9.91E-04	4.48E-04	1.05E-01
Gen-2	Black-Start Generator	Caterpillar, 2889 HP	250	0.80	1.93	0.72	1.43E-03	1.88E-04	6.61E-04	2.04E-02	1.28E-02	0.09E-04	5.17E-04	1.29E-01	2.70E-04										9.91E-04	4.48E-04	1.05E-01
Gen-3	Black-Start Generator	Caterpillar, 2889 HP	250	0.80	1.93	0.72	1.43E-03	1.88E-04	6.61E-04	2.04E-02	1.28E-02	0.09E-04	5.17E-04	1.29E-01	2.70E-04										9.91E-04	4.48E-04	1.05E-01
AD	Auxiliary Boiler	Heater, 66 MMBtu/hr	760	1.23	2.07	0.14	0.01	0.19							5.95E-05				1.44E-03	4.43E-02				4.93E-05		4.93E-02	
B-2	Reaction Heater	Heater, 12 MMBtu/hr	760	0.23	0.25	0.03	0.00	0.04							5.57E-05				3.48E-04	8.35E-03				1.59E-05		8.73E-03	
B-3	HGT Reactor Charge Heater	Heater, 2 MMBtu/hr	760	0.04	0.07	0.00	0.00	0.01							9.92E-07				6.20E-05	1.49E-03				2.81E-06		1.68E-03	
GP-1	Gasifier Preheater	Heater, 21.00 MMBtu/hr	500	0.26	0.43	0.03	3.09E-03	0.04							1.08E-05				3.86E-04	3.28E-03				1.76E-05		9.69E-03	
GP-2	Gasifier Preheater	Heater, 21.00 MMBtu/hr	500	0.26	0.43	0.03	3.09E-03	0.04							1.08E-05				3.86E-04	3.28E-03				1.76E-05		9.69E-03	
GP-3	Gasifier Preheater	Heater, 21.00 MMBtu/hr	500	0.26	0.43	0.03	3.09E-03	0.04							1.08E-05				3.86E-04	3.28E-03				1.76E-05		9.69E-03	
GP-4	Gasifier Preheater	Heater, 21.00 MMBtu/hr	500	0.26	0.43	0.03	3.09E-03	0.04							1.08E-05				3.86E-04	3.28E-03				1.76E-05		9.69E-03	
GP-5	Gasifier Preheater	Heater, 21.00 MMBtu/hr	500	0.26	0.43	0.03	3.09E-03	0.04							1.08E-05				3.86E-04	3.28E-03				1.76E-05		9.69E-03	
CO <sub>2</sub> VS	CO <sub>2</sub> Vent Stack		250				274.88	0.82																		0.00E+00	
FL-1	HP / Emergency Flare <sup>1</sup>	Venting to Flare, 0.816 MMBtu/hr	60	9.78	80.88	0.14	187.70																			0.00E+00	
FL-2	LP Flare <sup>1</sup>	Venting to Flare, 0.204 MMBtu/hr	20	0.03	0.19	0.00	36.01																			0.00E+00	
Total Emissions (Cold Startup Only, Partial Year)				43.44	383.49	5.03	227.76	15.42	2.48E-03	1.88E-01	4.81E-02	1.81E-03	1.58E-02	6.00E+00	6.99E-06	3.77E-02	4.74E-01	1.01E-01	4.89E-03	0.00E+00	1.53E-03	2.59E-03	3.41E-01	1.56E-01	7.97E-02	1.98	

Notes:  
<sup>1</sup> Flare operating hours include cold startup and malfunctions. Up to 60 hr/yr of venting to the HP Flare and up to 20 hr/yr of venting to the LP Flare are included. Flare emissions are included above in the Normal Operations summary.

TOTAL EMISSIONS FOR COLD STARTUP YEAR	Potential Emissions (t/yr)					HAPs Emissions (t/yr)														TOTALS			
	NO <sub>x</sub>	CO	VOC	SO <sub>2</sub>	PM <sub>10</sub>	1,2-Dichlorobenzene	Acealdehyde	Acrolein	2,2,4-Trimethylpentane	Benzene	Carbonyl Sulfide	Dichlorobenzene	Ethyl Benzene	Formaldehyde	Hexane	Mercury	Methanol	Naphthalene	PAH		Propylene Oxide	Toluene	Xylene
	251.01	514.16	201.09	255.62	192.73	0.01	0.45	0.10	0.00	11.08	0.28	0.50	0.35	1.10	0.81	0.00	12.75	0.01	0.02	0.20	1.82	0.78	28.80

Medicine Bow Fuel & Power Industrial Gasification & Liquefaction Plant  
 Turbine Detail Sheet - Initial Year (Cold Start and Remainder Normal Operations [Base Load])

Source ID Number	Turbine and HRSG Train 1		
Equipment ID			
Turbine Usage	Power Generation		
Turbine Make	GE		
Turbine Model	7EA		
Serial Number	TBD		
Installation Date	TBD		
Engine Configuration	Turbine		
Emission Controls	SCR/Oxidation Catalyst		
Design Output	66 MW		
Site Operating Hours	7760 hr/yr		
Exhaust Temperature	300 °F		
Gas Heating Value	-12°F	45°F	85°F
	16399.6 Btu/lb	16399.6 Btu/lb	16399.6 Btu/lb
Gas Flow Rate	47,910 lb/hr	44,450 lb/hr	40,240 lb/hr
Gas Heat Rate	785.7 MMBtu/hr	729.0 MMBtu/hr	659.9 MMBtu/hr

Potential Emissions from Fuel Gas Mixture Operation (Normal operations, Partial year)

Pollutant	Emission Factor (ppmv, dry)	Emission Factor (lb/MMBtu)	Estimated Hourly Emissions			Max Hourly Emissions (lb/hr)	Estimated Annual Emissions (tpy)	Source of Emission Factor
			-12°F (lb/hr)	45°F (lb/hr)	85°F (lb/hr)			
NOx	6	0.0234	18.40	17.44	16.12	18.40	67.20	Manf. Data <sup>1</sup>
CO	6	0.0143	11.20	10.62	9.81	11.20	40.92	Manf. Data <sup>1</sup>
VOC	1.4 (ppmv, wet)	0.0020	1.59	1.52	1.40	1.59	5.84	Manf. Data <sup>1</sup>
SO2		0.0034	2.67	2.48	2.24	2.67	9.56	AP-42 <sup>2</sup>
PM10 Total		0.0127	10.00	10.00	10.00	10.00	36.80	Manf. Data <sup>1</sup>
Mercury	2.24E-06	3.81E-08	2.89E-05	2.84E-05	2.62E-05	2.99E-05	1.08E-04	Manf. Data <sup>1</sup>
1,3-Butadiene		4.30E-07	3.38E-04	3.13E-04	2.84E-04	3.38E-04	1.21E-03	AP-42 <sup>2</sup>
Acetaldehyde		4.00E-05	3.14E-02	2.92E-02	2.84E-02	3.14E-02	1.12E-01	AP-42 <sup>2</sup>
Acrolein		6.40E-06	5.03E-03	4.67E-03	4.22E-03	5.03E-03	1.80E-02	AP-42 <sup>2</sup>
Benzene		1.20E-05	9.43E-03	8.75E-03	7.92E-03	9.43E-03	3.37E-02	AP-42 <sup>2</sup>
Ethylbenzene		3.20E-05	2.51E-02	2.33E-02	2.11E-02	2.51E-02	9.00E-02	AP-42 <sup>2</sup>
Formaldehyde		7.10E-05	5.58E-02	5.18E-02	4.69E-02	5.58E-02	2.00E-01	AP-42 <sup>2</sup>
Naphthalene		1.30E-06	1.02E-03	9.48E-04	8.58E-04	1.02E-03	3.66E-03	AP-42 <sup>2</sup>
PAH		2.20E-06	1.73E-03	1.60E-03	1.45E-03	1.73E-03	6.19E-03	AP-42 <sup>2</sup>
Propylene Oxide		2.90E-05	2.28E-02	2.11E-02	1.81E-02	2.28E-02	8.16E-02	AP-42 <sup>2</sup>
Toluene		1.30E-04	1.02E-01	9.48E-02	8.58E-02	1.02E-01	3.66E-01	AP-42 <sup>2</sup>
Xylene		6.40E-05	5.03E-02	4.67E-02	4.22E-02	5.03E-02	1.80E-01	AP-42 <sup>2</sup>

Exhaust Composition	Base Load, Temp. = -12°F		Base Load, Temp. = 45°F		Base Load, Temp. = 85°F	
	Mol. Wt.	Volume %	Weighted Mol Wt.	Volume %	Weighted Mol Wt.	Volume %
Argon	39.94	1.03	0.41	1.03	0.41	1.03
Nitrogen	28.02	77.34	21.67	76.82	21.52	76.61
Oxygen	32.00	12.08	3.87	12.22	3.91	12.37
Carbon Dioxide	44.01	3.32	1.46	3.23	1.42	3.17
Water	18.02	6.23	1.12	6.71	1.21	6.73
		100.0	28.5	100.0	28.5	99.9

Calculation of dry mass flow rate:	Base Load, Temp. = 0°F	Base Load, Temp. = 45°F	Base Load, Temp. = 80°F
Mass flow of exhaust =	2.03E+06 lb/hr	1.93E+06 lb/hr	1.78E+06 lb/hr
Molar flow of exhaust = Mass flow of exhaust / Mol Wt =	71079.6 lb-mol/hr	67738.0 lb-mol/hr	62614.9 lb-mol/hr
Molar flow of water = Vol.% H <sub>2</sub> O * Exhaust molar flow =	4428.3 lb-mol/hr	4545.2 lb-mol/hr	4214.0 lb-mol/hr
Molar flow of O <sub>2</sub> = Vol.% O <sub>2</sub> * Exhaust molar flow =	8585.4 lb-mol/hr	8277.6 lb-mol/hr	7745.5 lb-mol/hr
Molar flow of Exhaust, dry = Exhaust molar flow - H <sub>2</sub> O molar flow =	66651.4 lb-mol/hr	63192.8 lb-mol/hr	58400.9 lb-mol/hr
Vol. % O <sub>2</sub> , dry = O <sub>2</sub> molar flow / Exhaust molar flow =	12.9%	13.1%	13.3%

<sup>1</sup> Criteria pollutant emission factors provided by the manufacturer, but in some cases have been adapted from natural gas combustion. The NOx emission factor is corrected to 15% O<sub>2</sub>.

<sup>2</sup> EPA AP-42, Volume I, Fifth Edition - April 2000, Table 3.1-3, Emission Factors for Hazardous Air Pollutants from Natural Gas-Fired Stationary Gas Turbines. Note: These emission factors are for natural gas combustion, which is expected to produce emissions of these pollutants that are very similar to the emissions produced during fuel gas combustion, so these emission factors should provide representative emission estimates.

Additional notes:

All gas flow rates and compositions are based on information provided by GE. (Information provided by Paul Rood of SNC Lavalin via email on 12/17/07.)

Average VOC molecular weight assumed to be 46 lb-mol/lb.

The operating hours include 500 hours for malfunction and warm start-up.

Medicine Bow Fuel & Power Industrial Gasification & Liquefaction Plant  
Turbine Detail Sheet - SSM Emissions, Natural Gas Firing (Cold Start-up)

Design Output	66 MW
Cold Operating Hours	6 hr/yr
Normal Operating Hours	994 hr/yr
Natural Gas Heating Value	21515 Btu/lb
Natural Gas Flow Rate	36,495 lb/hr
Natural Gas Heat Rate	785.2 MMBtu/hr
Gas Flow Rate	0.77 MMscf/hr

Potential Emissions from Natural Gas Operation (Cold Startup, Partial year)

Pollutant	Emission Factor (lb/MMBtu)	Emission Factor (ppmv, dry)	Estimated Emissions		Source of Emission Factor
			(lb/hr)	(tpy)	
NOx (cold)		25	77.56	0.23	Manf. Data <sup>1</sup>
NOx (normal)		6	18.61	9.25	Manf. Data <sup>1</sup>
CO (cold)		10	18.89	0.06	Manf. Data <sup>1</sup>
CO (normal)		6	11.33	5.63	Manf. Data <sup>1</sup>
VOC		1.4 (ppmv, wet)	1.62	0.81	Manf. Data <sup>1</sup>
SO2	0.0034		2.67	1.33	Eng. Est. <sup>4</sup>
PM10 Total			10.00	5.00	Manf. Data <sup>1</sup>
Mercury		2.240E-06	3.03E-05	1.52E-05	Manf. Data <sup>1</sup>
1,3-Butadiene	4.30E-07		3.38E-04	1.69E-04	AP-42 <sup>2</sup>
Acetaldehyde	4.00E-05		3.14E-02	1.57E-02	AP-42 <sup>2</sup>
Acrolein	6.40E-06		5.03E-03	2.51E-03	AP-42 <sup>2</sup>
Benzene	1.20E-05		9.42E-03	4.71E-03	AP-42 <sup>2</sup>
Ethylbenzene	3.20E-05		2.51E-02	1.26E-02	AP-42 <sup>2</sup>
Formaldehyde	7.10E-05		5.57E-02	2.78E-02	AP-42 <sup>2</sup>
Naphthalene	1.30E-06		1.02E-03	5.10E-04	AP-42 <sup>2</sup>
PAH	2.20E-06		1.73E-03	8.64E-04	AP-42 <sup>2</sup>
Propylene Oxide	2.90E-05		2.28E-02	1.14E-02	AP-42 <sup>2</sup>
Toluene	1.30E-04		1.02E-01	5.10E-02	AP-42 <sup>2</sup>
Xylene	6.40E-05		5.03E-02	2.51E-02	AP-42 <sup>2</sup>

Exhaust Composition		Base Load, Temp. = 0°F	
Component	Mol. Wt.	Volume %	Weighted Mol Wt.
Argon	39.94	0.8	0.36
Nitrogen	28.02	76.5	21.18
Oxygen	32.00	13.88	4.44
Carbon Dioxide	44.01	3.22	1.42
Water	18.02	6.5	1.17
		100.0	28.5

Calculation of dry mass flow rate:

Mass flow of exhaust =	2.08E+06	lb/hr	
Molar flow of exhaust = Mass flow of exhaust / Mol Wt =	72132.9	lb-mol/hr	
Molar flow of water = Vol.% H <sub>2</sub> O * Exhaust molar flow =	4688.6	lb-mol/hr	
Molar Flow of O <sub>2</sub> = Vol.% O <sub>2</sub> * Exhaust molar flow =	10012.0	lb-mol/hr	
Molar flow of Exhaust, dry = Exhaust molar flow - H <sub>2</sub> O molar flow =	67444.3	lb-mol/hr	
Vol. % O <sub>2</sub> , dry = O <sub>2</sub> molar flow / Exhaust molar flow =	14.8%		

<sup>1</sup> Criteria pollutant emission factors provided by the manufacturer. The NOx emission factor is corrected to 15% O<sub>2</sub>. Cold operation emissions assume that the SCR / oxidation catalyst is not operating. Nitrogen injection is assumed; however, nitrogen may not be available until the Air separation Unit is operating.

<sup>2</sup> EPA AP-42, Volume I, Fifth Edition - April 2000, Table 3.1-3, Emission Factors for Hazardous Air Pollutants from Natural Gas-Fired Stationary Gas Turbines.

Additional notes:

These emissions are calculated assuming an ambient temperature of -12°F, which produces the worst case emission estimate.

All natural gas heat rates, flow rates, and exhaust compositions are based on information provided by GE. (Information provided by Paul Rood of SNC Lavalin via email on 12/18/07.)

Average VOC molecular weight assumed to be 46 lb-mol/lb.

Medicine Bow Fuel & Power Industrial Gasification & Liquefaction Plant  
Turbine Detail Sheet - Normal Operations (Base Load)

Source ID Number	Turbine and HRSG Train 1		
Equipment ID			
Turbine Usage	Power Generation		
Turbine Make	GE		
Turbine Model	7EA		
Serial Number	TBD		
Installation Date	TBD		
Engine Configuration	Turbine		
Emission Controls	SCR/Oxidation Catalyst		
Design Output	66 MW		
Site Operating Hours	8760 hr/yr		
Exhaust Temperature	300 °F		
	-12°F	45°F	85°F
Gas Heating Value	16399.6 Btu/lb	16399.6 Btu/lb	16399.6 Btu/lb
Gas Flow Rate	47,910 lb/hr	44,450 lb/hr	40,240 lb/hr
Gas Heat Rate	785.7 MMBtu/hr	729.0 MMBtu/hr	659.9 MMBtu/hr

Potential Emissions from Fuel Gas Mixture Operation

Pollutant	Emission Factor (ppmv, dry)	Emission Factor (lb/MMBtu)	Estimated Hourly Emissions			Max Hourly Emissions (lb/hr)	Estimated Annual Emissions (tpy)	Source of Emission Factor
			-12°F (lb/hr)	45°F (lb/hr)	85°F (lb/hr)			
NOx	6	0.0234	18.40	17.44	16.12	18.40	75.88	Manf. Data <sup>1</sup>
CO	6	0.0143	11.20	10.62	9.81	11.20	46.19	Manf. Data <sup>1</sup>
VOC	1.4 (ppmv, wet)	0.0020	1.59	1.52	1.40	1.59	6.59	Manf. Data <sup>1</sup>
SO2		0.0034	2.67	2.48	2.24	2.67	10.79	AP-42 <sup>2</sup>
PM10 Total		0.0127	10.00	10.00	10.00	10.00	43.80	Manf. Data <sup>1</sup>
Mercury	2.24E-06	3.81E-08	2.99E-05	2.84E-05	2.62E-05	2.99E-05	1.23E-04	Manf. Data <sup>1</sup>
1,3-Butadiene		4.30E-07	3.38E-04	3.13E-04	2.84E-04	3.38E-04	1.37E-03	AP-42 <sup>2</sup>
Acetaldehyde		4.00E-05	3.14E-02	2.92E-02	2.64E-02	3.14E-02	1.27E-01	AP-42 <sup>2</sup>
Acrolein		6.40E-06	5.03E-03	4.67E-03	4.22E-03	5.03E-03	2.03E-02	AP-42 <sup>2</sup>
Benzene		1.20E-05	9.43E-03	8.75E-03	7.92E-03	9.43E-03	3.81E-02	AP-42 <sup>2</sup>
Ethylbenzene		3.20E-05	2.51E-02	2.33E-02	2.11E-02	2.51E-02	1.02E-01	AP-42 <sup>2</sup>
Formaldehyde		7.10E-05	5.58E-02	5.18E-02	4.69E-02	5.58E-02	2.25E-01	AP-42 <sup>2</sup>
Naphthalene		1.30E-06	1.02E-03	9.48E-04	8.58E-04	1.02E-03	4.13E-03	AP-42 <sup>2</sup>
PAH		2.20E-06	1.73E-03	1.60E-03	1.45E-03	1.73E-03	6.98E-03	AP-42 <sup>2</sup>
Propylene Oxide		2.90E-05	2.28E-02	2.11E-02	1.91E-02	2.28E-02	9.21E-02	AP-42 <sup>2</sup>
Toluene		1.30E-04	1.02E-01	9.48E-02	8.58E-02	1.02E-01	4.13E-01	AP-42 <sup>2</sup>
Xylene		6.40E-05	5.03E-02	4.67E-02	4.22E-02	5.03E-02	2.03E-01	AP-42 <sup>2</sup>

Exhaust Composition	Component	Mol. Wt.	Base Load, Temp. = -12°F		Base Load, Temp. = 45°F		Base Load, Temp. = 85°F	
			Volume %	Weighted Mol Wt.	Volume %	Weighted Mol Wt.	Volume %	Weighted Mol Wt.
	Argon	39.94	1.03	0.41	1.03	0.41	1.03	0.41
	Nitrogen	28.02	77.34	21.87	76.82	21.52	76.61	21.47
	Oxygen	32.00	12.08	3.87	12.22	3.91	12.37	3.96
	Carbon Dioxide	44.01	3.32	1.46	3.23	1.42	3.17	1.40
	Water	18.02	6.23	1.12	6.71	1.21	6.73	1.21
			100.0	28.5	100.0	28.5	99.9	28.4

Calculation of dry mass flow rate:	Base Load, Temp. = 0°F	Base Load, Temp. = 45°F	Base Load, Temp. = 80°F
Mass flow of exhaust =	2.03E+06 lb/hr	1.93E+06 lb/hr	1.78E+06 lb/hr
Molar flow of exhaust = Mass flow of exhaust / Mol Wt =	71079.6 lb-mol/hr	67738.0 lb-mol/hr	62614.9 lb-mol/hr
Molar flow of water = Vol.% H <sub>2</sub> O * Exhaust molar flow =	4428.3 lb-mol/hr	4545.2 lb-mol/hr	4214.0 lb-mol/hr
Molar Flow of O <sub>2</sub> = Vol.% O <sub>2</sub> * Exhaust molar flow =	6586.4 lb-mol/hr	6277.6 lb-mol/hr	5845.5 lb-mol/hr
Molar flow of Exhaust, dry = Exhaust molar flow - H <sub>2</sub> O molar flow =	66851.4 lb-mol/hr	63192.8 lb-mol/hr	58400.9 lb-mol/hr
Vol. % O <sub>2</sub> , dry = O <sub>2</sub> molar flow / Exhaust molar flow =	12.9%	13.1%	13.3%

<sup>1</sup>Criteria pollutant emission factors provided by the manufacturer, but in some cases have been adapted from natural gas combustion. The NOx emission factor is corrected to 15% O<sub>2</sub>.

<sup>2</sup>EPA AP-42, Volume I, Fifth Edition - April 2000, Table 3.1-3, Emission Factors for Hazardous Air Pollutants from Natural Gas-Fired Stationary Gas Turbines. Note: These emission factors are for natural gas combustion, which is expected to produce emissions of these pollutants that are greater than or equal to the emissions produced during fuel gas combustion, so these emission factors should provide worst case emission estimates.

Additional notes:

All gas flow rates and compositions are based on information provided by GE. (Information provided by Paul Rood of SNC Lavalin via email on 12/17/07.)

Average VOC molecular weight assumed to be 46 lb-mol/lb.

Medicine Bow Fuel & Power Industrial Gasification & Liquefaction Plant  
Turbine Detail Sheet - Initial Year (Cold Start and Remainder Normal Operations [Base Load])

Source ID Number	Turbine and HRSG Train 2		
Equipment ID			
Turbine Usage	Power Generation		
Turbine Make	GE		
Turbine Model	7EA		
Serial Number	TBD		
Installation Date	TBD		
Engine Configuration	Turbine		
Emission Controls	SCR/Oxidation Catalyst		
Design Output	86 MW		
Site Operating Hours	7760 hr/yr		
Exhaust Temperature	300 °F		
	-12°F	45°F	85°F
Gas Heating Value	16399.6 Btu/lb	16399.6 Btu/lb	16399.6 Btu/lb
Gas Flow Rate	47,910 lb/hr	44,450 lb/hr	40,240 lb/hr
Gas Heat Rate	785.7 MMBtu/hr	729.0 MMBtu/hr	659.9 MMBtu/hr

Potential Emissions from Fuel Gas Mixture Operation (Normal operations, Partial year)

Pollutant	Emission Factor (ppmv, dry)	Emission Factor (lb/MMBtu)	Estimated Hourly Emissions			Max Hourly Emissions (lb/hr)	Estimated Annual Emissions (tpy)	Source of Emission Factor
			-12°F	45°F	85°F			
NOx	6	0.0234	18.40	17.44	16.12	18.40	67.20	Manf. Data <sup>1</sup>
CO	6	0.0143	11.20	10.62	9.81	11.20	40.92	Manf. Data <sup>1</sup>
VOC	1.4 (ppmv, wet)	0.0020	1.59	1.52	1.40	1.59	5.84	Manf. Data <sup>1</sup>
SO2		0.0034	2.67	2.48	2.24	2.67	9.56	AP-42 <sup>2</sup>
PM10 Total		0.0127	10.00	10.00	10.00	10.00	38.80	Manf. Data <sup>1</sup>
Mercury	2.24E-06	3.81E-08	2.99E-05	2.84E-05	2.62E-05	2.99E-05	1.09E-04	Manf. Data <sup>1</sup>
1,3-Butadiene		4.30E-07	3.38E-04	3.13E-04	2.84E-04	3.38E-04	1.21E-03	AP-42 <sup>2</sup>
Acetaldehyde		4.00E-05	3.14E-02	2.92E-02	2.64E-02	3.14E-02	1.12E-01	AP-42 <sup>2</sup>
Acrolein		8.40E-06	5.03E-03	4.67E-03	4.22E-03	5.03E-03	1.80E-02	AP-42 <sup>2</sup>
Benzene		1.20E-05	9.43E-03	8.75E-03	7.92E-03	9.43E-03	3.37E-02	AP-42 <sup>2</sup>
Ethylbenzene		3.20E-05	2.51E-02	2.33E-02	2.11E-02	2.51E-02	9.00E-02	AP-42 <sup>2</sup>
Formaldehyde		7.10E-05	5.58E-02	5.18E-02	4.69E-02	5.58E-02	2.00E-01	AP-42 <sup>2</sup>
Naphthalene		1.30E-06	1.02E-03	9.48E-04	8.58E-04	1.02E-03	3.66E-03	AP-42 <sup>2</sup>
PAH		2.20E-06	1.73E-03	1.60E-03	1.45E-03	1.73E-03	6.19E-03	AP-42 <sup>2</sup>
Propylene Oxide		2.90E-05	2.28E-02	2.11E-02	1.91E-02	2.28E-02	8.16E-02	AP-42 <sup>2</sup>
Toluene		1.30E-04	1.02E-01	9.48E-02	8.58E-02	1.02E-01	3.66E-01	AP-42 <sup>2</sup>
Xylene		6.40E-05	5.03E-02	4.67E-02	4.22E-02	5.03E-02	1.80E-01	AP-42 <sup>2</sup>

Exhaust Composition	Component	Mol. Wt.	Base Load, Temp. = -12°F		Base Load, Temp. = 45°F		Base Load, Temp. = 85°F	
			Volume %	Weighted Mol Wt.	Volume %	Weighted Mol Wt.	Volume %	Weighted Mol Wt.
	Argon	39.94	1.03	0.41	1.03	0.41	1.03	0.41
	Nitrogen	28.02	77.34	21.67	76.82	21.52	76.81	21.47
	Oxygen	32.00	12.08	3.87	12.22	3.91	12.37	3.96
	Carbon Dioxide	44.01	3.32	1.46	3.23	1.42	3.17	1.40
	Water	18.02	6.23	1.12	6.71	1.21	6.73	1.21
			100.0	28.5	100.0	28.5	99.9	28.4

Calculation of dry mass flow rate:	Base Load, Temp. = 0°F	Base Load, Temp. = 45°F	Base Load, Temp. = 80°F
Mass flow of exhaust =	2.03E+06 lb/hr	1.93E+06 lb/hr	1.78E+06 lb/hr
Molar flow of exhaust = Mass flow of exhaust / Mol Wt =	71079.6 lb-mol/hr	67738.0 lb-mol/hr	62614.9 lb-mol/hr
Molar flow of water = Vol.% H <sub>2</sub> O * Exhaust molar flow =	4428.3 lb-mol/hr	4545.2 lb-mol/hr	4214.0 lb-mol/hr
Molar Flow of O <sub>2</sub> = Vol.% O <sub>2</sub> * Exhaust molar flow =	8586.4 lb-mol/hr	8277.8 lb-mol/hr	7746.5 lb-mol/hr
Molar flow of Exhaust, dry = Exhaust molar flow - H <sub>2</sub> O molar flow =	66651.4 lb-mol/hr	63192.8 lb-mol/hr	58400.9 lb-mol/hr
Vol. % O <sub>2</sub> , dry = O <sub>2</sub> molar flow / Exhaust molar flow =	12.9%	13.1%	13.3%

<sup>1</sup> Criteria pollutant emission factors provided by the manufacturer, but in some cases have been adapted from natural gas combustion. The NOx emission factor is corrected to 15% O<sub>2</sub>.

<sup>2</sup> EPA AP-42, Volume I, Fifth Edition - April 2000, Table 3.1-3, Emission Factors for Hazardous Air Pollutants from Natural Gas-Fired Stationary Gas Turbines. Note: These emission factors are for natural gas combustion, which is expected to produce emissions of these pollutants that are very similar to the emissions produced during fuel gas combustion, so these emission factors should provide representative emission estimates.

Additional notes:

All gas flow rates and compositions are based on information provided by GE. (Information provided by Paul Rood of SNC Lavalin via email on 12/17/07.)

Average VOC molecular weight assumed to be 46 lb-mol/lb.

The operating hours include 500 hours for malfunction and warm start-up.

Medicine Bow Fuel & Power Industrial Gasification & Liquefaction Plant  
Turbine Detail Sheet - SSM Emissions, Natural Gas Firing (Cold Start-up)

Design Output	86 MW
Cold Operating Hours	6 hr/yr
Normal Operating Hours	994 hr/yr
Natural Gas Heating Value	21515 Btu/lb
Natural Gas Flow Rate	36,495 lb/hr
Natural Gas Heat Rate	785.2 MMBtu/hr
Gas Flow Rate	0.77 MMscf/hr

Potential Emissions from Natural Gas Operation (Cold Startup, Partial year)

Pollutant	Emission Factor (lb/MMBtu)	Emission Factor (ppmv, dry)	Estimated Emissions		Source of Emission Factor
			(lb/hr)	(tpy)	
NOx (cold)		25	77.56	0.23	Manf. Data <sup>1</sup>
NOx (normal)		6	18.61	9.25	Manf. Data <sup>1</sup>
CO (cold)		10	18.89	0.06	Manf. Data <sup>1</sup>
CO (normal)		6	11.33	5.63	Manf. Data <sup>1</sup>
VOC		1.4 (ppmv, wet)	1.62	0.81	Manf. Data <sup>1</sup>
SO2	0.0034		2.67	1.33	Manf. Data <sup>1</sup>
PM10 Total			10.00	5.00	Manf. Data <sup>1</sup>
Mercury		2.240E-06	3.03E-05	1.52E-05	Manf. Data <sup>1</sup>
1,3-Butadiene	4.30E-07		3.38E-04	1.69E-04	AP-42 <sup>2</sup>
Acetaldehyde	4.00E-05		3.14E-02	1.57E-02	AP-42 <sup>2</sup>
Acrolein	6.40E-06		5.03E-03	2.51E-03	AP-42 <sup>2</sup>
Benzene	1.20E-05		9.42E-03	4.71E-03	AP-42 <sup>2</sup>
Ethylbenzene	3.20E-05		2.51E-02	1.26E-02	AP-42 <sup>2</sup>
Formaldehyde	7.10E-05		5.57E-02	2.79E-02	AP-42 <sup>2</sup>
Naphthalene	1.30E-06		1.02E-03	5.10E-04	AP-42 <sup>2</sup>
PAH	2.20E-06		1.73E-03	8.64E-04	AP-42 <sup>2</sup>
Propylene Oxide	2.90E-05		2.28E-02	1.14E-02	AP-42 <sup>2</sup>
Toluene	1.30E-04		1.02E-01	5.10E-02	AP-42 <sup>2</sup>
Xylene	6.40E-05		5.03E-02	2.51E-02	AP-42 <sup>2</sup>

Component	Mol. Wt.	Volume %	Base Load, Temp. = 0°F	
			Weighted Mol Wt.	
Argon	39.94	0.8	0.36	
Nitrogen	28.02	75.5	21.16	
Oxygen	32.00	13.88	4.44	
Carbon Dioxide	44.01	3.22	1.42	
Water	18.02	6.5	1.17	
		100.0	28.5	

Calculation of dry mass flow rate:

Mass flow of exhaust =	2.06E+06	lb/hr		
Molar flow of exhaust = Mass flow of exhaust / Mol Wt =			72132.9	lb-mol/hr
Molar flow of water = Vol.% H <sub>2</sub> O * Exhaust molar flow =			4688.6	lb-mol/hr
Molar Flow of O <sub>2</sub> = Vol.% O <sub>2</sub> * Exhaust molar flow =			10012.0	lb-mol/hr
Molar flow of Exhaust, dry = Exhaust molar flow - H <sub>2</sub> O molar flow =			67444.3	lb-mol/hr
Vol. % O <sub>2</sub> , dry = O <sub>2</sub> molar flow / Exhaust molar flow =			14.8%	

<sup>1</sup> Criteria pollutant emission factors provided by the manufacturer. The NOx emission factor is corrected to 15% O<sub>2</sub>. Cold operation emissions assume that the SCR / oxidation catalyst is not operating. Nitrogen Injection is assumed.

<sup>2</sup> EPA AP-42, Volume 1, Fifth Edition - April 2000, Table 3.1-3, Emission Factors for Hazardous Air Pollutants from Natural Gas-Fired Stationary Gas Turbines.

Additional notes:

These emissions are calculated assuming an ambient temperature of -12°F, which produces the worst case emission estimate.

All natural gas heat rates, flow rates, and exhaust compositions are based on information provided by GE. (Information provided by Paul Rood of SNC Lavalin via email on 12/18/07.)

Average VOC molecular weight assumed to be 46 lb-mol/lb.



Medicine Bow Fuel & Power Industrial Gasification & Liquefaction Plant  
Turbine Detail Sheet - Normal Operations (Base Load)

Source ID Number	Turbine and HRSG Train 2		
Equipment ID			
Turbine Usage	Power Generation		
Turbine Make	GE		
Turbine Model	7EA		
Serial Number	TBD		
Installation Date	TBD		
Engine Configuration	Turbine		
Emission Controls	SCR/Oxidation Catalyst		
Design Output	66 MW		
Site Operating Hours	8760 hr/yr		
Exhaust Temperature	300 °F		
	-12°F	45°F	85°F
Gas Heating Value	16399.6 Btu/lb	16399.6 Btu/lb	16399.6 Btu/lb
Gas Flow Rate	47,910 lb/hr	44,450 lb/hr	40,240 lb/hr
Gas Heat Rate	785.7 MMBtu/hr	729.0 MMBtu/hr	659.9 MMBtu/hr

Potential Emissions from Fuel Gas Mixture Operation

Pollutant	Emission Factor (ppmv, dry)	Emission Factor (lb/MMBtu)	Estimated Hourly Emissions			Max Hourly Emissions (lb/hr)	Estimated Annual Emissions (tpy)	Source of Emission Factor
			-12°F (lb/hr)	45°F (lb/hr)	85°F (lb/hr)			
NOx	6	0.0234	18.40	17.44	16.12	18.40	75.86	Manf. Data <sup>1</sup>
CO	6	0.0143	11.20	10.62	9.81	11.20	46.19	Manf. Data <sup>1</sup>
VOC	1.4 (ppmv, wet)	0.0020	1.59	1.52	1.40	1.59	6.59	Manf. Data <sup>1</sup>
SO2		0.0034	2.67	2.48	2.24	2.67	10.79	AP-42 <sup>2</sup>
PM10 Total		0.0127	10.00	10.00	10.00	10.00	43.80	Manf. Data <sup>1</sup>
Mercury	2.24E-06	3.81E-08	2.99E-05	2.84E-05	2.62E-05	2.99E-05	1.23E-04	Manf. Data <sup>1</sup>
1,3-Butadiene		4.30E-07	3.38E-04	3.13E-04	2.84E-04	3.38E-04	1.37E-03	AP-42 <sup>2</sup>
Acetaldehyde		4.00E-05	3.14E-02	2.92E-02	2.64E-02	3.14E-02	1.27E-01	AP-42 <sup>2</sup>
Acrolein		6.40E-06	5.03E-03	4.67E-03	4.22E-03	5.03E-03	2.03E-02	AP-42 <sup>2</sup>
Benzene		1.20E-05	9.43E-03	8.76E-03	7.92E-03	9.43E-03	3.81E-02	AP-42 <sup>2</sup>
Ethylbenzene		3.20E-05	2.51E-02	2.33E-02	2.11E-02	2.51E-02	1.02E-01	AP-42 <sup>2</sup>
Formaldehyde		7.10E-05	5.59E-02	5.18E-02	4.69E-02	5.59E-02	2.25E-01	AP-42 <sup>2</sup>
Naphthalene		1.30E-06	1.02E-03	9.48E-04	8.59E-04	1.02E-03	4.13E-03	AP-42 <sup>2</sup>
PAH		2.20E-06	1.73E-03	1.60E-03	1.45E-03	1.73E-03	6.98E-03	AP-42 <sup>2</sup>
Propylene Oxide		2.90E-05	2.28E-02	2.11E-02	1.91E-02	2.28E-02	9.21E-02	AP-42 <sup>2</sup>
Toluene		1.30E-04	1.02E-01	9.48E-02	8.59E-02	1.02E-01	4.13E-01	AP-42 <sup>2</sup>
Xylene		6.40E-05	5.03E-02	4.67E-02	4.22E-02	5.03E-02	2.03E-01	AP-42 <sup>2</sup>

Exhaust Composition	Component	Mol. Wt.	Base Load, Temp. = -12°F		Base Load, Temp. = 45°F		Base Load, Temp. = 85°F	
			Volume %	Weighted Mol	Volume %	Weighted Mol	Volume %	Weighted Mol
	Argon	39.94	1.03	0.41	1.03	0.41	1.03	0.41
	Nitrogen	28.02	77.34	21.67	76.82	21.52	76.81	21.47
	Oxygen	32.00	12.08	3.87	12.22	3.91	12.37	3.86
	Carbon Dioxide	44.01	3.32	1.46	3.29	1.42	3.17	1.40
	Water	18.02	6.23	1.12	6.71	1.21	6.73	1.21
			100.0	28.5	100.0	28.5	99.9	28.4

Calculation of dry mass flow rate:	Base Load, Temp. = 0°F	Base Load, Temp. = 45°F	Base Load, Temp. = 80°F
Mass flow of exhaust =	2.03E+06 lb/hr	1.83E+06 lb/hr	1.78E+06 lb/hr
Molar flow of exhaust = Mass flow of exhaust / Mol Wt =	71079.6 lb-mol/hr	67798.0 lb-mol/hr	62614.9 lb-mol/hr
Molar flow of water = Vol.% H <sub>2</sub> O * Exhaust molar flow =	4428.3 lb-mol/hr	4545.2 lb-mol/hr	4214.0 lb-mol/hr
Molar Flow of O <sub>2</sub> = Vol.% O <sub>2</sub> * Exhaust molar flow =	8586.4 lb-mol/hr	8277.6 lb-mol/hr	7745.5 lb-mol/hr
Molar flow of Exhaust, dry = Exhaust molar flow - H <sub>2</sub> O molar flow =	66651.4 lb-mol/hr	63192.8 lb-mol/hr	58400.9 lb-mol/hr
Vol. % O <sub>2</sub> , dry = O <sub>2</sub> molar flow / Exhaust molar flow =	12.9%	13.1%	13.3%

<sup>1</sup> Criteria pollutant emission factors provided by the manufacturer, but in some cases have been adapted from natural gas combustion. The NOx emission factor is corrected to 15% O<sub>2</sub>.

<sup>2</sup> EPA AP-42, Volume I, Fifth Edition - April 2000, Table 3.1-3, Emission Factors for Hazardous Air Pollutants from Natural Gas-Fired Stationary Gas Turbines. Note: These emission factors are for natural gas combustion, which is expected to produce emissions of these pollutants that are greater than or equal to the emissions produced during fuel gas combustion, so these emission factors should provide worst case emission estimates.

Additional notes:

All gas flow rates and compositions are based on information provided by GE. (Information provided by Paul Rood of SNC Lavalin via email on 12/17/07.)

Average VOC molecular weight assumed to be 46 lb-mol/lb.

Medicine Bow Fuel & Power Industrial Gasification & Liquefaction Plant  
Turbine Detail Sheet - Initial Year (Cold Start and Remainder Normal Operations [Base Load])

Source ID Number	Turbine and HRSG Train 3		
Equipment ID			
Turbine Usage	Power Generation		
Turbine Make	GE		
Turbine Model	7EA		
Serial Number	TBD		
Installation Date	TBD		
Engine Configuration	Turbine		
Emission Controls	SCR/Oxidation Catalyst		
Design Output	86 MW		
Site Operating Hours	7760 hr/yr		
Exhaust Temperature	300 °F		
	-12°F	45°F	85°F
Gas Heating Value	16399.6 Btu/lb	16399.6 Btu/lb	16399.6 Btu/lb
Gas Flow Rate	47,910 lb/hr	44,450 lb/hr	40,240 lb/hr
Gas Heat Rate	785.7 MMBtu/hr	729.0 MMBtu/hr	659.9 MMBtu/hr

Potential Emissions from Fuel Gas Mixture Operation (Normal operations, Partial year)

Pollutant	Emission Factor (ppmv, dry)	Emission Factor (lb/MMBtu)	Estimated Hourly Emissions			Max Hourly Emissions (lb/hr)	Estimated Annual Emissions (tpy)	Source of Emission Factor
			-12°F (lb/hr)	45°F (lb/hr)	85°F (lb/hr)			
NOx	6	0.0234	18.40	17.44	16.12	18.40	67.20	Manf. Data <sup>1</sup>
CO	6	0.0143	11.20	10.62	9.81	11.20	40.92	Manf. Data <sup>1</sup>
VOC	1.4 (ppmv, wet)	0.0020	1.59	1.52	1.40	1.59	5.84	Manf. Data <sup>1</sup>
SO2		0.0034	2.67	2.48	2.24	2.67	9.56	AP-42 <sup>2</sup>
PM10 Total		0.0127	10.00	10.00	10.00	10.00	38.80	Manf. Data <sup>1</sup>
Mercury	2.24E-06	3.81E-08	2.99E-05	2.84E-05	2.62E-05	2.99E-05	1.09E-04	Manf. Data <sup>1</sup>
1,3-Butadiene		4.30E-07	3.38E-04	3.13E-04	2.84E-04	3.38E-04	1.21E-03	AP-42 <sup>2</sup>
Acetaldehyde		4.00E-05	3.14E-02	2.92E-02	2.84E-02	3.14E-02	1.12E-01	AP-42 <sup>2</sup>
Acrolein		6.40E-06	5.08E-03	4.67E-03	4.22E-03	5.08E-03	1.80E-02	AP-42 <sup>2</sup>
Benzene		1.20E-05	9.43E-03	8.75E-03	7.92E-03	9.43E-03	3.37E-02	AP-42 <sup>2</sup>
Ethylbenzene		3.20E-05	2.51E-02	2.33E-02	2.11E-02	2.51E-02	9.00E-02	AP-42 <sup>2</sup>
Formaldehyde		7.10E-05	5.58E-02	5.18E-02	4.69E-02	5.58E-02	2.00E-01	AP-42 <sup>2</sup>
Naphthalene		1.30E-06	1.02E-03	9.48E-04	8.58E-04	1.02E-03	3.66E-03	AP-42 <sup>2</sup>
PAH		2.20E-06	1.78E-03	1.60E-03	1.45E-03	1.78E-03	6.19E-03	AP-42 <sup>2</sup>
Propylene Oxide		2.90E-05	2.28E-02	2.11E-02	1.91E-02	2.28E-02	8.16E-02	AP-42 <sup>2</sup>
Toluene		1.30E-04	1.02E-01	9.48E-02	8.58E-02	1.02E-01	3.66E-01	AP-42 <sup>2</sup>
Xylene		6.40E-05	5.03E-02	4.67E-02	4.22E-02	5.03E-02	1.80E-01	AP-42 <sup>2</sup>

Exhaust Composition	Base Load, Temp. = -12°F		Base Load, Temp. = 45°F		Base Load, Temp. = 85°F	
	Mol. Wt.	Volume %	Weighted Mol	Weighted Mol	Volume %	Weighted Mol Wt.
Argon	39.94	1.03	0.41	0.41	1.03	0.41
Nitrogen	28.02	77.34	21.67	76.82	76.61	21.47
Oxygen	32.00	12.08	3.87	12.22	3.91	3.95
Carbon Dioxide	44.01	3.32	1.46	3.23	3.17	1.40
Water	18.02	6.23	1.12	6.71	6.73	1.21
		100.0	28.5	100.0	99.9	28.4

Calculation of dry mass flow rate:	Base Load, Temp. = 0°F	Base Load, Temp. = 45°F	Base Load, Temp. = 80°F
Mass flow of exhaust =	2.03E+06 lb/hr	1.93E+06 lb/hr	1.78E+06 lb/hr
Molar flow of exhaust = Mass flow of exhaust / Mol Wt. =	71079.6 lb-mol/hr	67738.0 lb-mol/hr	62614.9 lb-mol/hr
Molar flow of water = Vol.% H <sub>2</sub> O * Exhaust molar flow =	4428.3 lb-mol/hr	4545.2 lb-mol/hr	4214.0 lb-mol/hr
Molar flow of O <sub>2</sub> = Vol.% O <sub>2</sub> * Exhaust molar flow =	8586.4 lb-mol/hr	8277.6 lb-mol/hr	7745.5 lb-mol/hr
Molar flow of Exhaust, dry = Exhaust molar flow - H <sub>2</sub> O molar flow =	66651.4 lb-mol/hr	63192.8 lb-mol/hr	58400.9 lb-mol/hr
Vol. % O <sub>2</sub> , dry = O <sub>2</sub> molar flow / Exhaust molar flow =	12.9%	13.1%	13.3%

<sup>1</sup> Criteria pollutant emission factors provided by the manufacturer, but in some cases have been adapted from natural gas combustion. The NOx emission factor is corrected to 15% O<sub>2</sub>.

<sup>2</sup> EPA AP-42, Volume I, Fifth Edition - April 2000, Table 3.1-3, Emission Factors for Hazardous Air Pollutants from Natural Gas-Fired Stationary Gas Turbines. Note: These emission factors are for natural gas combustion, which is expected to produce emissions of these pollutants that are greater than or equal to the emissions produced during fuel gas combustion, so these emission factors should provide worst case emission estimates.

Additional notes:

All gas flow rates and compositions are based on information provided by GE. (Information provided by Paul Rood of SNC Lavalin via email on 12/17/07.)

Average VOC molecular weight assumed to be 46 lb-mol/lb.

The operating hours include 500 hours for malfunction and warm start-up.

Medicine Bow Fuel & Power Industrial Gasification & Liquefaction Plant  
Turbine Detail Sheet - SSM Emissions, Natural Gas Firing (Cold Startup)

Design Output	66 MW
Cold Operating Hours	6 hr/yr
Normal Operating Hours	894 hr/yr
Natural Gas Heating Value	21515 Btu/lb
Natural Gas Flow Rate	36,495 lb/hr
Natural Gas Heat Rate	785.2 MMBtu/hr
Gas Flow Rate	0.77 MMscf/hr

Potential Emissions from Natural Gas Operation (Cold Startup, Partial year)

Pollutant	Emission Factor (lb/MMBtu)	Emission Factor (ppmv, dry)	Estimated Emissions		Source of Emission Factor
			(lb/hr)	(tpy)	
NOx (cold)		25	77.56	0.23	Manf. Data <sup>1</sup>
NOx (normal)		6	18.51	9.25	Manf. Data <sup>1</sup>
CO (cold)		10	18.89	0.06	Manf. Data <sup>1</sup>
CO (normal)		6	11.33	5.63	Manf. Data <sup>1</sup>
VOC		1.4 (ppmv, wet)	1.62	0.81	Manf. Data <sup>1</sup>
SO2	0.0034		2.67	1.33	Manf. Data <sup>1</sup>
PM10 Total			10.00	5.00	Manf. Data <sup>1</sup>
Mercury		2.240E-06	3.03E-05	1.82E-05	Manf. Data <sup>1</sup>
1,3-Butadiene	4.30E-07		3.38E-04	1.69E-04	AP-42 <sup>2</sup>
Acetaldehyde	4.00E-05		3.14E-02	1.57E-02	AP-42 <sup>2</sup>
Acrolein	6.40E-06		5.03E-03	2.51E-03	AP-42 <sup>2</sup>
Benzene	1.20E-05		9.42E-03	4.71E-03	AP-42 <sup>2</sup>
Ethylbenzene	3.20E-05		2.51E-02	1.26E-02	AP-42 <sup>2</sup>
Formaldehyde	7.10E-05		5.57E-02	2.79E-02	AP-42 <sup>2</sup>
Naphthalene	1.30E-06		1.02E-03	5.10E-04	AP-42 <sup>2</sup>
PAH	2.20E-06		1.73E-03	8.64E-04	AP-42 <sup>2</sup>
Propylene Oxide	2.90E-05		2.28E-02	1.14E-02	AP-42 <sup>2</sup>
Toluene	1.30E-04		1.02E-01	5.10E-02	AP-42 <sup>2</sup>
Xylene	6.40E-05		5.03E-02	2.51E-02	AP-42 <sup>2</sup>

Exhaust Composition

Base Load, Temp. = 0°F

Component	Mol. Wt.	Volume %	Weighted Mol	
			Vol.	Wt.
Argon	39.94	0.9	0.36	
Nitrogen	28.02	75.5	21.16	
Oxygen	32.00	13.88	4.44	
Carbon Dioxide	44.01	3.22	1.42	
Water	18.02	6.5	1.17	
		100.0	28.5	

Calculation of dry mass flow rates:

Mass flow of exhaust =	2.06E+06	lb/hr		
Molar flow of exhaust = Mass flow of exhaust / Mol Wt =	72132.9	lb-mol/hr		
Molar flow of water = Vol.% H <sub>2</sub> O * Exhaust molar flow =	4888.6	lb-mol/hr		
Molar Flow of O <sub>2</sub> = Vol.% O <sub>2</sub> * Exhaust molar flow =	10012.0	lb-mol/hr		
Molar flow of Exhaust, dry = Exhaust molar flow - H <sub>2</sub> O molar flow =	67444.3	lb-mol/hr		
Vol. % O <sub>2</sub> , dry = O <sub>2</sub> molar flow / Exhaust molar flow =	14.8%			

<sup>1</sup> Criteria pollutant emission factors provided by the manufacturer. The NOx emission factor is corrected to 15% O<sub>2</sub>. Cold operation emissions assume that the SCR / oxidation catalyst is not operating. Nitrogen injection is assumed.

<sup>2</sup> EPA AP-42, Volume I, Fifth Edition - April 2000, Table 3.1-3, Emission Factors for Hazardous Air Pollutants from Natural Gas-Fired Stationary Gas Turbines.

Additional notes:

These emissions are calculated assuming an ambient temperature of -12°F, which produces the worst case emission estimate.

All natural gas heat rates, flow rates, and exhaust compositions are based on information provided by GE. (Information provided by Paul Rood of SNC Lavalin via email on 12/18/07.)

Average VOC molecular weight assumed to be 46 lb-mol/lb.

Medicine Bow Fuel & Power Industrial Gasification & Liquefaction Plant  
Turbine Detail Sheet - Normal Operations (Base Load)

Source ID Number	Turbine and HRSG Train 3		
Equipment ID			
Turbine Usage	Power Generation		
Turbine Make	GE		
Turbine Model	7EA		
Serial Number	TBD		
Installation Date	TBD		
Engine Configuration	Turbine		
Emission Controls	SCR/Oxidation Catalyst		
Design Output	66 MW		
Site Operating Hours	8760 hr/yr		
Exhaust Temperature	300 °F		
	-12°F	45°F	85°F
Gas Heating Value	16399.6 Btu/lb	16399.6 Btu/lb	16399.6 Btu/lb
Gas Flow Rate	47,910 lb/hr	44,450 lb/hr	40,240 lb/hr
Gas Heat Rate	785.7 MMBtu/hr	729.0 MMBtu/hr	659.9 MMBtu/hr

Potential Emissions from Fuel Gas Mixture Operation

Pollutant	Emission Factor (ppmv, dry)	Emission Factor (lb/MMBtu)	Estimated Hourly Emissions			Max Hourly Emissions (lb/hr)	Estimated Annual Emissions (tpy)	Source of Emission Factor
			-12°F (lb/hr)	45°F (lb/hr)	85°F (lb/hr)			
NOx	6	0.0234	18.40	17.44	16.12	18.40	75.86	Manf. Data <sup>1</sup>
CO	6	0.0143	11.20	10.62	9.81	11.20	46.19	Manf. Data <sup>1</sup>
VOC	1.4 (ppmv, wet)	0.0020	1.59	1.52	1.40	1.59	6.59	Manf. Data <sup>1</sup>
SO2		0.0034	2.67	2.48	2.24	2.67	10.79	AP-42 <sup>2</sup>
PM10 Total		0.0127	10.00	10.00	10.00	10.00	43.80	Manf. Data <sup>1</sup>
Mercury	2.24E-06	3.81E-08	2.99E-05	2.84E-05	2.62E-05	2.99E-05	1.23E-04	Manf. Data <sup>1</sup>
1,3-Butadiene		4.30E-07	3.38E-04	3.13E-04	2.84E-04	3.38E-04	1.37E-03	AP-42 <sup>2</sup>
Acetaldehyde		4.00E-05	3.14E-02	2.92E-02	2.64E-02	3.14E-02	1.27E-01	AP-42 <sup>2</sup>
Acrolein		6.40E-06	5.03E-03	4.67E-03	4.22E-03	5.03E-03	2.03E-02	AP-42 <sup>2</sup>
Benzene		1.20E-05	9.43E-03	8.76E-03	7.92E-03	9.43E-03	3.81E-02	AP-42 <sup>2</sup>
Ethylbenzene		3.20E-05	2.51E-02	2.33E-02	2.11E-02	2.51E-02	1.02E-01	AP-42 <sup>2</sup>
Formaldehyde		7.10E-05	5.58E-02	5.18E-02	4.69E-02	5.58E-02	2.25E-01	AP-42 <sup>2</sup>
Naphthalene		1.30E-06	1.02E-03	9.48E-04	8.58E-04	1.02E-03	4.13E-03	AP-42 <sup>2</sup>
PAH		2.20E-06	1.73E-03	1.60E-03	1.45E-03	1.73E-03	6.98E-03	AP-42 <sup>2</sup>
Propylene Oxide		2.90E-05	2.28E-02	2.11E-02	1.91E-02	2.28E-02	9.21E-02	AP-42 <sup>2</sup>
Toluene		1.30E-04	1.02E-01	9.48E-02	8.58E-02	1.02E-01	4.13E-01	AP-42 <sup>2</sup>
Xylene		6.40E-05	5.03E-02	4.67E-02	4.22E-02	5.03E-02	2.03E-01	AP-42 <sup>2</sup>

Exhaust Composition	Base Load, Temp. = -12°F		Base Load, Temp. = 45°F		Base Load, Temp. = 85°F	
	Mol. Wt.	Volume %	Weighted Mol Wt.	Volume %	Weighted Mol Wt.	Volume %
Argon	39.94	1.03	0.41	1.03	0.41	1.03
Nitrogen	28.02	77.34	21.67	76.82	21.52	76.61
Oxygen	32.00	12.08	3.87	12.22	3.91	12.37
Carbon Dioxide	44.01	3.32	1.48	3.23	1.42	3.17
Water	18.02	6.23	1.12	6.71	1.21	6.73
		100.0	28.5	100.0	28.5	99.9

Calculation of dry mass flow rate:	Base Load, Temp. = 0°F	Base Load, Temp. = 45°F	Base Load, Temp. = 80°F
Mass flow of exhaust =	2.03E+06 lb/hr	1.93E+06 lb/hr	1.78E+06 lb/hr
Molar flow of exhaust = Mass flow of exhaust / Mol Wt =	71079.6 lb-mol/hr	67738.0 lb-mol/hr	62614.9 lb-mol/hr
Molar flow of water = Vol.% H <sub>2</sub> O * Exhaust molar flow =	4428.3 lb-mol/hr	4545.2 lb-mol/hr	4214.0 lb-mol/hr
Molar flow of O <sub>2</sub> = Vol.% O <sub>2</sub> * Exhaust molar flow =	8588.4 lb-mol/hr	8277.6 lb-mol/hr	7745.5 lb-mol/hr
Molar flow of Exhaust, dry = Exhaust molar flow - H <sub>2</sub> O molar flow =	66651.4 lb-mol/hr	63192.8 lb-mol/hr	58400.9 lb-mol/hr
Vol. % O <sub>2</sub> , dry = O <sub>2</sub> molar flow / Exhaust molar flow =	12.9%	13.1%	13.3%

<sup>1</sup> Criteria pollutant emission factors provided by the manufacturer, but in some cases have been adapted from natural gas combustion. The NOx emission factor is corrected to 15% O<sub>2</sub>.

<sup>2</sup> EPA AP-42, Volume I, Fifth Edition - April 2000, Table 3.1-3, Emission Factors for Hazardous Air Pollutants from Natural Gas-Fired Stationary Gas Turbines. Note: These emission factors are for natural gas combustion, which is expected to produce emissions of these pollutants that are greater than or equal to the emissions produced during fuel gas combustion, so these emission factors should provide worst case emission estimates.

Additional notes:

All gas flow rates and compositions are based on information provided by GE. (Information provided by Paul Rood of SNC Lavalin via email on 12/17/07.)

Average VOC molecular weight assumed to be 46 lb-mol/lb.

**Medicine Bow Fuel & Power Industrial Gasification & Liquefaction Plant  
Auxiliary Boiler Detail Sheet**

Source ID Number		Vent Gas Molar Flow Rate	215 lb-mol/hr
Equipment Usage	Auxiliary Boiler	Vent Gas Molecular Weight	18.5 lb/lb-mol
Equipment Make	TBD	Vent Gas Percent H2O	0.1%
Equipment Model	TBD	Vent Gas Molar Flow Rate (dry)	215 lb-mol/hr
Serial Number	TBD	Vent Gas Flow Rate (dry)	81,510 scf/hr
Installation Date	TBD		
Emission Controls	Low Nox Burner		
Design Heat Rate	66.00 MMBtu/hr		
<b>Normal Operation</b>			
Gas Potential Operation	8000 hr/yr		
Gas Potential Fuel Usage	652 MMscf/yr		
<b>Cold Startup (natural gas)</b>			
Fuel Heating Value	1020 Btu/scf		
Heat Rate	0.0647 MMscf/hr		
NG Potential Operation	760 hr/yr		
NG Potential Fuel Usage	49.18 MMscf/yr		

*Potential Emissions from Normal Operation (firing fuel gas mixture, 25% load)*

Pollutant	Emission Factor (lb/MMBtu)	Emission Factor (lb/MMscf)	Estimated Emissions		Source of Emission Factor
			(lb/hr)	(tpy)	
NOx	0.036	---	0.59	2.38	Vendor <sup>1</sup>
CO	0.037	---	0.61	2.44	Vendor <sup>1</sup>
VOC	0.004	---	0.07	0.26	Vendor <sup>1</sup>
SO2	0.0006	---	0.01	0.04	Vendor <sup>1</sup>
PM10	0.005	---	0.08	0.33	Vendor <sup>1</sup>
Benzene	---	2.1E-03	4.28E-05	1.71E-04	AP-42 <sup>3</sup>
Dichlorobenzene	---	1.2E-03	2.45E-05	9.78E-05	AP-42 <sup>3</sup>
Formaldehyde	---	7.5E-02	1.53E-03	6.11E-03	AP-42 <sup>3</sup>
Hexane	---	1.8E+00	3.67E-02	1.47E-01	AP-42 <sup>3</sup>
Naphthalene	---	6.1E-04	1.24E-05	4.97E-05	AP-42 <sup>3</sup>
Toluene	---	3.4E-03	6.93E-05	2.77E-04	AP-42 <sup>3</sup>

<sup>1</sup> NOx, CO, VOC, SO2, and PM10 emissions are estimated based on vendor specifications.

<sup>2</sup> EPA AP-42, Volume I, Fifth Edition - July 1998, Table 1.4-2, Emission Factors for Criteria Pollutants and Greenhouse Gases from Natural Gas Combustion. Note: These emission factors are for natural gas combustion, which is expected to produce emissions of these pollutants that are greater than or equal to the emissions produced during syn gas combustion, so these emission factors should provide worst case emission estimates.

<sup>3</sup> EPA AP-42, Volume I, Fifth Edition - July 1998, Table 1.4-3, Emission Factors for Speciated Organic Compounds from Natural Gas Combustion. Note: These emission factors are for natural gas combustion, which is expected to produce emissions of these pollutants that are greater than or equal to the emissions produced during syn gas combustion, so these emission factors should provide worst case emission estimates.

**Additional notes:**

The vent gas molar flow rates are from the material balance in the Feasibility Study, dated October 2007.

The PAH emission factor is a sum of all the constituent PAH emission factors in Table 1.4-3.

For annual emissions shown on the summary sheet, operation on fuel gas and natural gas have been pro-rated accordingly for normal operation and initial year operation.

Medicine Bow Fuel & Power Industrial Gasification & Liquefaction Plant Cont.  
 Auxillary Boiler Detail Sheet

Potential Emissions from Startup Operation (firing natural gas at 100% load)

Pollutant	Emission Factor (lb/MMscf)	Estimated Emissions		Source of Emission Factor
		(lb/hr)	(tpy)	
NOx	50.00	3.24	1.23	AP-42 <sup>1</sup>
CO	84.00	5.44	2.07	AP-42 <sup>1</sup>
VOC	5.50	0.36	0.14	AP-42 <sup>2</sup>
SO2	0.60	0.04	1.48E-02	AP-42 <sup>2</sup>
PM10	7.60	0.49	0.19	AP-42 <sup>2</sup>
Benzene	2.1E-03	1.36E-04	5.16E-05	AP-42 <sup>3</sup>
Dichlorobenzene	1.2E-03	7.76E-05	2.95E-05	AP-42 <sup>3</sup>
Formaldehyde	7.5E-02	4.85E-03	1.84E-03	AP-42 <sup>3</sup>
Hexane	1.8E+00	1.16E-01	4.43E-02	AP-42 <sup>3</sup>
Toluene	3.4E-03	2.20E-04	8.36E-05	AP-42 <sup>3</sup>

<sup>1</sup> EPA AP-42, Volume I, Fifth Edition - July 1998, Table 1.4-1, Emission Factors for Nitrogen Oxides (NOx) and Carbon Monoxide (CO) from Natural Gas Combustion.

<sup>2</sup> EPA AP-42, Volume I, Fifth Edition - July 1998, Table 1.4-2, Emission Factors for Criteria Pollutants and Greenhouse Gases from Natural Gas Combustion.

<sup>3</sup> EPA AP-42, Volume I, Fifth Edition - July 1998, Table 1.4-3, Emission Factors for Speciated Organic Compounds from Natural Gas Combustion.

**Medicine Bow Fuel & Power Industrial Gasification & Liquefaction Plant  
Heater Detail Sheet**

Source ID Number	Catalyst Regenerator	Vent Gas Molar Flow Rate	12 lb-mol/hr
Equipment Usage	Process Heater	Vent Gas Molecular Weight	18.5 lb/lb-mol
Equipment Make	TBD	Vent Gas Percent H2O	0.1%
Equipment Model	TBD	Vent Gas Molar Flow Rate (dry)	12 lb-mol/hr
Serial Number	TBD	Vent Gas Flow Rate (dry)	4,421 scf/hr
Installation Date	TBD		
Emission Controls	Low NOx Burner		
Design Heat Rate	3.58 MMBtu/hr		
<u>Normal Operation</u>			
Gas Potential Operation	7123 hr/yr		
Gas Potential Fuel Usage	31 MMscf/yr		

*Potential Emissions from Normal Operation in Standby (firing fuel gas mixture)*

Pollutant	Emission Factor (lb/MMscf)	Estimated Emissions		Source of Emission Factor
		(lb/hr)	(tpy)	
NOx	30.00	0.13	0.47	Vendor <sup>1</sup>
CO	84.00	0.37	1.32	AP-42 <sup>1</sup>
VOC	5.50	0.02	0.09	AP-42 <sup>2</sup>
SO2	0.60	0.00	0.01	AP-42 <sup>2</sup>
PM10	7.60	0.03	0.12	AP-42 <sup>2</sup>
Benzene	2.1E-03	9.28E-06	3.31E-05	AP-42 <sup>3</sup>
Dichlorobenzene	1.2E-03	5.31E-06	1.89E-05	AP-42 <sup>3</sup>
Formaldehyde	7.5E-02	3.32E-04	1.18E-03	AP-42 <sup>3</sup>
Hexane	1.8E+00	7.96E-03	2.83E-02	AP-42 <sup>3</sup>
Naphthalene	6.1E-04	2.70E-06	9.61E-06	AP-42 <sup>3</sup>
Toluene	3.4E-03	1.50E-05	5.35E-05	AP-42 <sup>3</sup>

<sup>1</sup> NOx emissions are estimated based on vendor specifications.

<sup>2</sup> EPA AP-42, Volume I, Fifth Edition - July 1998, Table 1.4-2, Emission Factors for Criteria Pollutants and Greenhouse Gases from Natural Gas Combustion. Note: These emission factors are for natural gas combustion, which is expected to produce emissions of these pollutants that are greater than or equal to the emissions produced during syn gas combustion, so these emission factors should provide worst case emission estimates.

<sup>3</sup> EPA AP-42, Volume I, Fifth Edition - July 1998, Table 1.4-3, Emission Factors for Speciated Organic Compounds from Natural Gas Combustion. Note: These emission factors are for natural gas combustion, which is expected to produce emissions of these pollutants that are greater than or equal to the emissions produced during syn gas combustion, so these emission factors should provide worst case emission estimates.

Additional notes:

The vent gas molar flow rates are from the material balance in the Feasibility Study, dated October 2007.

**Medicine Bow Fuel & Power Industrial Gasification & Liquefaction Plant  
Heater Detail Sheet**

Source ID Number	Catalyst Regenerator	Vent Gas Molar Flow Rate	70 lb-mol/hr
Equipment Usage	Process Heater	Vent Gas Molecular Weight	18.5 lb/lb-mol
Equipment Make	TBD	Vent Gas Percent H2O	0.1%
Equipment Model	TBD	Vent Gas Molar Flow Rate (dry)	70 lb-mol/hr
Serial Number	TBD	Vent Gas Flow Rate (dry)	26,590 scf/hr
Installation Date	TBD		
Emission Controls	Low NOx Burner		
Design Heat Rate	21.53 MMBtu/hr		
<b>Normal Operation</b>			
Gas Potential Operation	877 hr/yr		
Gas Potential Fuel Usage	23 MMscf/yr		

*Potential Emissions from Catalyst Regeneration Operation (firing fuel gas mixture)*

Pollutant	Emission Factor (lb/MMscf)	Estimated Emissions		Source of Emission Factor
		(lb/hr)	(tpy)	
NOx	30.00	0.80	0.35	Vendor <sup>1</sup>
CO	84.00	2.23	0.98	AP-42 <sup>2</sup>
VOC	5.50	0.15	0.06	AP-42 <sup>2</sup>
SO2	0.60	0.02	0.01	AP-42 <sup>2</sup>
PM10	7.60	0.20	0.09	AP-42 <sup>2</sup>
Benzene	2.1E-03	5.58E-05	2.45E-05	AP-42 <sup>3</sup>
Dichlorobenzene	1.2E-03	3.19E-05	1.40E-05	AP-42 <sup>3</sup>
Formaldehyde	7.5E-02	1.99E-03	8.74E-04	AP-42 <sup>3</sup>
Hexane	1.8E+00	4.79E-02	2.10E-02	AP-42 <sup>3</sup>
Naphthalene	6.1E-04	1.62E-05	7.11E-06	AP-42 <sup>3</sup>
Toluene	3.4E-03	9.04E-05	3.96E-05	AP-42 <sup>3</sup>

<sup>1</sup> NOx emissions are estimated based on vendor specifications.

<sup>2</sup> EPA AP-42, Volume I, Fifth Edition - July 1998, Table 1.4-2, Emission Factors for Criteria Pollutants and Greenhouse Gases from Natural Gas Combustion. Note: These emission factors are for natural gas combustion, which is expected to produce emissions of these pollutants that are greater than or equal to the emissions produced during syn gas combustion, so these emission factors should provide worst case emission estimates.

<sup>3</sup> EPA AP-42, Volume I, Fifth Edition - July 1998, Table 1.4-3, Emission Factors for Speciated Organic Compounds from Natural Gas Combustion. Note: These emission factors are for natural gas combustion, which is expected to produce emissions of these pollutants that are greater than or equal to the emissions produced during syn gas combustion, so these emission factors should provide worst case emission estimates.

**Additional notes:**

The vent gas molar flow rates are from the material balance in the Feasibility Study, dated October 2007.



Medicine Bow Fuel & Power Industrial Gasification & Liquefaction Plant  
Heater Detail Sheet

Source ID Number	Reactivation Heater (B-2)	Vent Gas Molar Flow Rate	40 lb-mol/hr
Equipment Usage	Process Heater	Vent Gas Molecular Weight	18.6 lb/lb-mol
Equipment Make	TBD	Vent Gas Percent H2O	0.1%
Equipment Model	TBD	Vent Gas Molar Flow Rate (dry)	40 lb-mol/hr
Serial Number	TBD	Vent Gas Flow Rate (dry)	15,327 scf/hr
Installation Date	TBD		
Emission Controls	Low NOx Burner		
Design Heat Rate	12.45 MMBtu/hr		
<u>Normal Operation</u>			
Gas Potential Operation	1456 hr/yr		
Gas Potential Fuel Usage	22 MMscf/yr		
<u>Cold Startup (natural gas)</u>			
Fuel Heating Value	1020 Btu/scf		
Heat Rate	0.0122 MMscf/hr		
NG Potential Operation	760 hr/yr		
NG Potential Fuel Usage	9.28 MMscf/yr		

*Potential Emissions from Normal Operation (firing fuel gas mixture)*

Pollutant	Emission Factor (lb/MMscf)	Estimated Emissions		Source of Emission Factor
		(lb/hr)	(tpy)	
NOx	30.0	0.46	0.33	Vendor <sup>1</sup>
CO	84.00	1.29	0.94	AP-42 <sup>1</sup>
VOC	5.50	0.08	0.06	AP-42 <sup>2</sup>
SO2	0.60	0.01	0.01	AP-42 <sup>2</sup>
PM10	7.60	0.12	0.08	AP-42 <sup>2</sup>
Benzene	2.1E-03	3.22E-05	2.34E-05	AP-42 <sup>3</sup>
Dichlorobenzene	1.2E-03	1.84E-05	1.34E-05	AP-42 <sup>3</sup>
Formaldehyde	7.5E-02	1.15E-03	8.37E-04	AP-42 <sup>3</sup>
Hexane	1.8E+00	2.76E-02	2.01E-02	AP-42 <sup>3</sup>
Naphthalene	6.1E-04	9.35E-06	6.81E-06	AP-42 <sup>3</sup>
Toluene	3.4E-03	5.21E-05	3.79E-05	AP-42 <sup>3</sup>

<sup>1</sup> NOx are estimated based on vendor specifications.

<sup>2</sup> EPA AP-42, Volume I, Fifth Edition - July 1998, Table 1.4-2, Emission Factors for Criteria Pollutants and Greenhouse Gases from Natural Gas Combustion. Note: These emission factors are for natural gas combustion, which is expected to produce emissions of these pollutants that are greater than or equal to the emissions produced during syn gas combustion, so these emission factors should provide worst case emission estimates.

<sup>3</sup> EPA AP-42, Volume I, Fifth Edition - July 1998, Table 1.4-3, Emission Factors for Speciated Organic Compounds from Natural Gas Combustion. Note: These emission factors are for natural gas combustion, which is expected to produce emissions of these pollutants that are greater than or equal to the emissions produced during syn gas combustion, so these emission factors should provide worst case emission estimates.

Additional notes:

The vent gas molar flow rates are from the material balance in the Feasibility Study, dated October 2007.

For annual emissions shown on the summary sheet, operation on fuel gas and natural gas have been pro-rated accordingly for normal operation and initial year operation.

Medicine Bow Fuel & Power Industrial Gasification & Liquefaction Plant, Cont.  
 Heater Detail Sheet

*Potential Emissions from Startup Operation (firing natural gas)*

Pollutant	Emission Factor (lb/MMscf)	Estimated Emissions		Source of Emission Factor
		(lb/hr)	(tpy)	
NOx	50.00	0.61	0.23	AP-42 <sup>1</sup>
CO	84.00	1.03	0.39	AP-42 <sup>1</sup>
VOC	5.50	0.07	0.03	AP-42 <sup>2</sup>
SO2	0.60	0.01	2.78E-03	AP-42 <sup>2</sup>
PM10	7.60	0.09	0.04	AP-42 <sup>2</sup>
Benzene	2.1E-03	2.56E-05	9.74E-06	AP-42 <sup>3</sup>
Dichlorobenzene	1.2E-03	1.46E-05	5.57E-06	AP-42 <sup>3</sup>
Formaldehyde	7.5E-02	9.15E-04	3.48E-04	AP-42 <sup>3</sup>
Hexane	1.8E+00	2.20E-02	8.35E-03	AP-42 <sup>3</sup>
Toluene	3.4E-03	4.15E-05	1.58E-05	AP-42 <sup>3</sup>

<sup>1</sup> EPA AP-42, Volume I, Fifth Edition - July 1998, Table 1.4-1, Emission Factors for Nitrogen Oxides (NOx) and Carbon Monoxide (CO) from Natural Gas Combustion.

<sup>2</sup> EPA AP-42, Volume I, Fifth Edition - July 1998, Table 1.4-2, Emission Factors for Criteria Pollutants and Greenhouse Gases from Natural Gas Combustion.

<sup>3</sup> EPA AP-42, Volume I, Fifth Edition - July 1998, Table 1.4-3, Emission Factors for Speciated Organic Compounds from Natural Gas Combustion.

**Medicine Bow Fuel & Power Industrial Gasification & Liquefaction Plant  
Heater Detail Sheet**

Source ID Number	HGT reactor Charge Heater (B-3)		
Equipment Usage	Process Heater	Vent Gas Molar Flow Rate	7 lb-mol/hr
Equipment Make	TBD	Vent Gas Molecular Weight	18.6 lb/lb-mol
Equipment Model	TBD	Vent Gas Percent H2O	1.0%
Serial Number	TBD	Vent Gas Molar Flow Rate (dry)	7 lb-mol/hr
Installation Date	TBD	Vent Gas Flow Rate (dry)	2,708 scf/hr
Emission Controls	Low NOx Burner		
Design Heat Rate	2.22 MMBtu/hr		
<u>Normal Operation</u>			
Gas Potential Operation	8000 hr/yr		
Gas Potential Fuel Usage	22 MMscf/yr		
<u>Cold Startup (natural gas)</u>			
Fuel Heating Value	1020 Btu/scf		
Heat Rate	0.0022 MMscf/hr		
NG Potential Operation	760 hr/yr		
NG Potential Fuel Usage	1.65 MMscf/yr		

*Potential Emissions from Normal Operation (firing fuel gas mixture)*

Pollutant	Emission Factor (lb/MMscf)	Estimated Emissions		Source of Emission Factor
		(lb/hr)	(tpy)	
NOx	30.0	0.08	0.33	Vendor <sup>1</sup>
CO	84.0	0.23	0.91	AP-42 <sup>1</sup>
VOC	5.50	0.01	0.06	AP-42 <sup>2</sup>
SO2	0.6	0.00	0.01	AP-42 <sup>2</sup>
PM10	7.60	0.02	0.08	AP-42 <sup>2</sup>
Benzene	1.2E-03	3.25E-06	1.30E-05	AP-42 <sup>3</sup>
Dichlorobenzene	7.5E-02	2.03E-04	8.13E-04	AP-42 <sup>3</sup>
Formaldehyde	1.8E+00	4.88E-03	1.95E-02	AP-42 <sup>3</sup>
Hexane	6.1E-04	1.65E-06	6.61E-06	AP-42 <sup>3</sup>
Naphthalene	3.4E-03	9.21E-06	3.68E-05	AP-42 <sup>3</sup>
Toluene	3.4E-03	7.37E-08	2.95E-07	AP-42 <sup>3</sup>

<sup>1</sup> NOx emissions are estimated based on vendor specifications.

<sup>2</sup> EPA AP-42, Volume I, Fifth Edition - July 1998, Table 1.4-2, Emission Factors for Criteria Pollutants and Greenhouse Gases from Natural Gas Combustion. Note: These emission factors are for natural gas combustion, which is expected to produce emissions of these pollutants that are greater than or equal to the emissions produced during syn gas combustion, so these emission factors should provide worst case emission estimates.

<sup>3</sup> EPA AP-42, Volume I, Fifth Edition - July 1998, Table 1.4-3, Emission Factors for Speciated Organic Compounds from Natural Gas Combustion. Note: These emission factors are for natural gas combustion, which is expected to produce emissions of these pollutants that are greater than or equal to the emissions produced during syn gas combustion, so these emission factors should provide worst case emission estimates.

**Additional notes:**

The vent gas molar flow rates are from the material balance in the Feasibility Study, dated October 2007.

For annual emissions shown on the summary sheet, operation on fuel gas and natural gas have been pro-rated accordingly for normal operation and initial year operation.

**Medicine Bow Fuel & Power Industrial Gasification & Liquefaction Plant, Cont.  
Heater Detail Sheet**

*Potential Emissions from Startup Operation (firing natural gas)*

Pollutant	Emission Factor (lb/MMscf)	Estimated Emissions		Source of Emission Factor
		(lb/hr)	(tpy)	
NOx	50.00	0.11	0.04	AP-42 <sup>1</sup>
CO	84.00	0.18	0.07	AP-42 <sup>1</sup>
VOC	5.50	0.01	0.00	AP-42 <sup>2</sup>
SO2	0.60	0.00	4.96E-04	AP-42 <sup>2</sup>
PM10	7.60	0.02	0.01	AP-42 <sup>2</sup>
Benzene	2.1E-03	4.57E-06	1.74E-06	AP-42 <sup>3</sup>
Dichlorobenzene	1.2E-03	2.61E-06	9.92E-07	AP-42 <sup>3</sup>
Formaldehyde	7.5E-02	1.63E-04	6.20E-05	AP-42 <sup>3</sup>
Hexane	1.8E+00	3.92E-03	1.49E-03	AP-42 <sup>3</sup>
Toluene	3.4E-03	7.40E-06	2.81E-06	AP-42 <sup>3</sup>

<sup>1</sup> EPA AP-42, Volume I, Fifth Edition - July 1998, Table 1.4-1, Emission Factors for Nitrogen Oxides (NOx) and Carbon Monoxide (CO) from Natural Gas Combustion.

<sup>2</sup> EPA AP-42, Volume I, Fifth Edition - July 1998, Table 1.4-2, Emission Factors for Criteria Pollutants and Greenhouse Gases from Natural Gas Combustion.

<sup>3</sup> EPA AP-42, Volume I, Fifth Edition - July 1998, Table 1.4-3, Emission Factors for Speciated Organic Compounds from Natural Gas Combustion.

Medicine Bow Fuel & Power Industrial Gasification & Liquefaction Plant  
Stack Detail Sheet

Source ID Number	CO2 Vent Stack	
Equipment Usage	Vent for Off-Spec CO2	
Equipment Make	TBD	
Equipment Model	TBD	
Serial Number	TBD	
Installation Date	TBD	
Emission Controls	None	
Potential Operation during initial startup	250 hr/yr	
Potential Operation during malfunctions	50 hr/yr	
Total Vent Stream Flowrate	21,712 lb-mol/hr	
<b>Initial Startup</b>		
Vent Gas Molar Flow Rate during startup	5,428 lb-mol/hr	
Vent Gas Molecular Weight	43.3 lb/lb-mol	
Vent Gas H2O Molar Flow Rate	0.20% lb-mol/hr	
Vent Gas Molar Flow Rate (dry)	5417 lb-mol/hr	
Vent Gas Flow Rate (dry)	2,056,158 scf/hr	
<b>Malfunction</b>		
Vent Gas Molar Flow Rate during malfunc	7,237 lb-mol/hr	
Vent Gas Molecular Weight	43.3 lb/lb-mol	
Vent Gas H2O Molar Flow Rate	0.20% lb-mol/hr	
Vent Gas Molar Flow Rate (dry)	7223 lb-mol/hr	
Vent Gas Flow Rate (dry)	2,741,543 scf/hr	

Potential Emissions from SSM Operation

Cold Startup Malfunction

Pollutant	Emission Factor ppmvd	Estimated Hourly Emissions		Max Hourly Emissions (lb/hr)	Total Annual Emissions (tpy)	Total Annual Emissions (tpy)	Source of Emission Factor
		Initial Startup (lb/hr)	Malfunction (lb/hr)				
CO	14,492	2198.87	2931.83	2931.83	274.86	73.30	Vendor <sup>1</sup>
VOC	0.5	0.15	0.20	0.20	0.02	0.01	Vendor <sup>1</sup>

<sup>1</sup> CO and VOC emissions are estimated based on vendor specifications.

Additional notes:

Vent gas molar flow rates are based on information in the Feasibility Study, dated Oct. 2007

VOC is in the form of carbonyl sulfide.

Annual emissions for this source have been estimated both for the first year of operation, which will include the initial startup emissions and malfunction emissions, and for subsequent years of operation, which will include only malfunction emissions.

The total potential flow rate from this source will only occur if all four gasifiers were operating at full load and both CO2 compressors were to fail. The flow rate at initial startup is estimated to be one-fourth of the total potential flow rate since at most only one gasifier will be operating at full load before the CO2 compression system is operational. The flow rate during a malfunction is estimated to be one-third of the total potential flow rate since at most only one of the three CO2 compressors could fail without a reduction in the production by the gasifiers.

Medicine Bow Fuel & Power Industrial Gasification & Liquefaction Plant  
HP Flare Detail Sheet

Source ID Number	Flare	
Equipment Usage	Emergency Flare/HP Flare	
Equipment Make	TBD	
Equipment Model	TBD	
Serial Number	TBD	
Installation Date	TBD	
Emission Controls	None	
Gas Flow Rate <sup>1</sup>	2,943,142 lb/hr	Syngas to flare (wet)
Gas Heat Content <sup>1</sup>	2,000 Btu/lb	
Flare Firing Rate	5,886 MMBtu/hr	(low BTU gas)
Hours of Operation	40 hrs/yr	Malfunctions
	10 hrs/yr	Initial Year (Cold Starts)
Pilot Fuel Flow Rate	800 scf/hr	
Pilot Fuel Heat Content	1,020 Btu/scf	Natural Gas (High BTU gas)
Flare Pilot Firing Rate	0.816 MMBtu/hr	
Hours of Operation, Pilot	8,760 hrs/yr	Continuous pilot

48" Diameter

Estimated Flare Gas Composition During Coal Firing

Component	Flow Rate (lb/hr)	Mol Wt. lb/lb-mol
CO	750,294	28
H2	48,330	2
CO2	489,061	44
H2O	1,625,960	18
CH4	1,199	16
Ar	14,974	40
N2	6,305	28
H2S	3,922	34
COS	270	60
NH3	2,797	17
Total	2,943,142	

Potential Emissions <sup>2</sup>

Pollutant	Emission Factors		Destruction Efficiency (%)	Estimated Emissions Pilot (Normal Operation) <sup>8</sup>		Estimated Emissions Cold Start & Malfunctions		Estimated Emissions Malfunctions only	
	Low BTU gas (lb/MMBtu)	High BTU gas (lb/MMBtu)		(lb/hr)	(tpy)	(lb/hr)	(tpy)	(lb/hr)	(tpy)
NOx <sup>3</sup>	0.0641	0.1380		0.11	0.5	391.30	9.8	391.30	7.8
CO <sup>4</sup>	0.5496	0.2755		0.22	1.0	3,235.10	80.9	3,249.31	65.0
VOC <sup>5,6</sup>			98%	0.68	3.0	5.40	0.1	6.08	0.1
SO2 <sup>7</sup>		0.0006		4.80E-04	2.1E-03	7,508.07	187.7	7,508.07	150.16

Notes:

- Flare gas composition, heat content, and flow rate are all from the Feasibility Study, dated 12/12/06.
- These emissions are based on the calculation methodology and emission factors presented in the TCEQ Guidance Document for Flares and Vapor Oxidizers (RG-109, October 2000). NOx, CO, and VOC emissions include constant pilot gas flow (natural gas).
- NOx emissions were calculated as a sum of the thermal and fuel generated NOx. Thermal NOx emissions were calculated using an emission factor from Table 4 (similar to CO) for an unassisted flare burning low Btu gas. Thermal NOx emissions from the continuous pilot were calculated using the Table 4 emission factor for high BTU gas. The fuel NOx emissions were calculated using the guidance in Table 4 that indicates NOx is 0.5 wt% of Inlet NH3.
- The CO emission factor is from Table 4 in the TCEQ Guidance Document and is for an unassisted flare burning low Btu gas. CO emissions for the continuous pilot were calculated using the TCEQ Table 4 emission factor for high BTU gas.
- Fuel VOC emissions were calculated based on guidance in the TCEQ Guidance Document which indicates that 98% of VOCs entering the flare in the fuel will be combusted. The emissions are equal to 2 percent of the incoming flow of COS.
- VOCs from pilot gas combustion are calculated assuming natural gas density of 0.0424 lb/scf, and destruction efficiency of 98%.
- SO2 emissions are a sum of the SO2 from the H2S combustion and from the COS combustion. Table 4 indicates that 98% of incoming H2S is converted to SO2, and since COS is a VOC, 98% of that compound will also be combusted and converted to SO2.
- Emissions from normal operations represent only the continuous pilot, since normal operation does not include high pressure vents to flare.

Medicine Bow Fuel & Power Industrial Gasification & Liquefaction Plant  
LP Flare Detail Sheet

Source ID Number	Flare		
Equipment Usage	Emergency Flare/LP Flare		
Equipment Make	TBD		
Equipment Model	TBD		
Serial Number	TBD		
Installation Date	TBD		
Emission Controls	None		
Gas Flow Rate <sup>1</sup>	3,989 lb/hr	Selexol Reflux Drum vent	24" diameter
Gas Heat Content <sup>1</sup>	8,831 Btu/lb		
Flare Firing Rate	35 MMBtu/hr	(low BTU gas)	
Hours of Operation	8 hrs/yr	Malfunctions	
	12 hrs/yr	Initial Year (Cold Starts)	
Pilot Fuel Flow Rate	200 scf/hr		
Pilot Fuel Heat Content	1,020 Btu/scf	Natural Gas (High BTU gas)	
Flare Pilot Firing Rate	0.204 MMBtu/hr		
Hours of Operation, Pilot	8,760 hrs/yr	Continuous pilot	

Estimated Flare Gas Composition During Coal Firing

Component	Flow Rate (lb/hr)	Mol Wt. lb/lb-mol
CO	160	28
H2	399	2
CO2	1,167	44
H2O	199	18
CH4	0	16
Ar	0	40
N2	0	28
H2S	1,955	34
COS	0	60
NH3	120	17
<b>Total</b>	<b>3,989</b>	

Potential Emissions <sup>2</sup>

Pollutant	Emission Factors		Destruction Efficiency (%)	Estimated Emissions Pilot (Normal Operation) <sup>7</sup>		Estimated Emissions Cold Start & Malfunction <sup>8</sup>		Estimated Emissions Malfunctions Only	
	Low BTU gas (lb/MMBtu)	High BTU gas (lb/MMBtu)		(lb/hr)	(tpy)	(lb/hr)	(tpy)	(lb/hr)	(tpy)
NOx <sup>3</sup>	0.0641	0.1380	98%	0.03	0.1	2.86	0.0	2.86	0.0
CO <sup>4</sup>	0.5496	0.2755		0.06	0.2	19.38	0.2	0.06	0.0
VOC <sup>5</sup>				0.17	0.7	0.00	0.0	0.17	0.0
SO2 <sup>6</sup>		0.0006		1.20E-04	5.3E-04	3,601.15	36.0	3,601.15	14.4

Notes:

- Flare gas composition and flow rate are from Flare RV Log, December 2007
- These emissions are based on the calculation methodology and emission factors presented in the TCEQ Guidance Document for Flares and Vapor Oxidizers (RG-109, October 2000). NOx, CO, and VOC emissions include constant pilot gas flow (natural gas).
- Fuel NOx emissions were calculated using TCEQ guidance (Table 4) that indicates NOx is 0.5 wt% of inlet NH3. Thermal NOx contribution from the process vent stream is assumed to be negligible; for the pilot gas, thermal NOx is calculated using the TCEQ Table 4 emission factor for high BTU gas.
- CO emissions for the continuous pilot were calculated using the TCEQ Table 4 emission factor for high BTU gas. TCEQ Table 4 emission factor for high BTU gas. CO emissions are from the pilot fuel only.
- VOCs from pilot gas combustion are calculated assuming natural gas density of 0.0424 lb/scf, and destruction efficiency of 98%.
- SO2 emissions are a sum of the SO2 from the H2S combustion and from the COS combustion. Table 4 indicates that 98% of incoming H2S is converted to SO2, and since COS is a VOC, 98% of that compound will also be combusted and converted to SO2.
- Emissions from normal operations represent only the continuous pilot, since normal operation does not include low pressure vents to flare.
- The initial year (i.e., cold start) emissions represent emissions from the low pressure vent gas to the flare. Emissions are estimated for the worst-case (high flow rate, high H2S content) vent stream directed to the LP Flare, and include both cold start and malfunction hours.

**Medicine Bow Fuel & Power Industrial Gasification & Liquefaction Plant  
Preheater Detail Sheet**

Source ID Number	Gasifier Preheater 1
Equipment Usage	Refractory Preheating
Equipment Make	TBD
Equipment Model	TBD
Serial Number	TBD
Installation Date	TBD
Emission Controls	None
Design Heat Rate	21.00 MMBtu/hr
<u>Cold Startup</u>	
Gas Heating Value	1020 Btu/scf
Gas Potential Operation	500 hr/yr
Gas Potential Fuel Usage	2.06E-02 MMscf/hr

*Potential Emissions from Startup Operation (firing natural gas)*

Pollutant	Emission Factor (lb/MMscf)	Estimated Emissions		Source of Emission Factor
		(lb/hr)	(tpy)	
NOx	50.00	1.03	0.26	AP-42 <sup>1</sup>
CO	84.00	1.73	0.43	AP-42 <sup>1</sup>
VOC	5.50	0.11	0.03	AP-42 <sup>2</sup>
SO2	0.60	0.01	3.09E-03	AP-42 <sup>2</sup>
PM10	7.60	0.16	0.04	AP-42 <sup>2</sup>
Benzene	2.1E-03	4.32E-05	1.08E-05	AP-42 <sup>3</sup>
Dichlorobenzene	1.2E-03	2.47E-05	6.18E-06	AP-42 <sup>3</sup>
Formaldehyde	7.5E-02	1.54E-03	3.86E-04	AP-42 <sup>3</sup>
Hexane	1.8E+00	3.71E-02	9.26E-03	AP-42 <sup>3</sup>
Toluene	3.4E-03	7.00E-05	1.75E-05	AP-42 <sup>3</sup>

<sup>1</sup> EPA AP-42, Volume I, Fifth Edition - September 1998, Table 1.4-1. Emission Factors for Nitrogen Oxides and Carbon Monoxide from Natural Gas Combustion

<sup>2</sup> EPA AP-42, Volume I, Fifth Edition - September 1998, Table 1.4-2. Emission Factors for Criteria Pollutants and Greenhouse Gases from Natural Gas Combustion

<sup>3</sup> EPA AP-42, Volume I, Fifth Edition - September 1998, Table 1.4-3. Emission Factors For Speciated Organic Compounds From Natural Gas Combustion

Additional notes:

The average heating value for natural gas is used in these calculations (as provided in Section 1.4 of AP-42).

The PAH emission factor is a sum of all the constituent PAH emission factors in Table 1.4-3.



**Medicine Bow Fuel & Power Industrial Gasification & Liquefaction Plant  
Preheater Detail Sheet**

Source ID Number	Gasifier Preheater 2
Equipment Usage	Refractory Preheating
Equipment Make	TBD
Equipment Model	TBD
Serial Number	TBD
Installation Date	TBD
Emission Controls	None
Design Heat Rate	21.00 MMBtu/hr
<b>Cold Startup</b>	
Gas Heating Value	1020 Btu/scf
Gas Potential Operation	500 hr/yr
Gas Potential Fuel Usage	2.06E-02 MMscf/hr

*Potential Emissions from Startup Operation (firing natural gas)*

Pollutant	Emission Factor (lb/MMscf)	Estimated Emissions		Source of Emission Factor
		(lb/hr)	(tpy)	
NOx	50.00	1.03	0.26	AP-42 <sup>1</sup>
CO	84.00	1.73	0.43	AP-42 <sup>1</sup>
VOC	5.50	0.11	0.03	AP-42 <sup>2</sup>
SO2	0.60	0.01	3.09E-03	AP-42 <sup>2</sup>
PM10	7.60	0.16	0.04	AP-42 <sup>2</sup>
Benzene	2.1E-03	4.32E-05	1.08E-05	AP-42 <sup>3</sup>
Dichlorobenzene	1.2E-03	2.47E-05	6.18E-06	AP-42 <sup>3</sup>
Formaldehyde	7.5E-02	1.54E-03	3.86E-04	AP-42 <sup>3</sup>
Hexane	1.8E+00	3.71E-02	9.26E-03	AP-42 <sup>3</sup>
Toluene	3.4E-03	7.00E-05	1.75E-05	AP-42 <sup>3</sup>

<sup>1</sup> EPA AP-42, Volume I, Fifth Edition - September 1998, Table 1.4-1. Emission Factors for Nitrogen Oxides and Carbon Monoxide from Natural Gas Combustion

<sup>2</sup> EPA AP-42, Volume I, Fifth Edition - September 1998, Table 1.4-2. Emission Factors for Criteria Pollutants and Greenhouse Gases from Natural Gas Combustion

<sup>3</sup> EPA AP-42, Volume I, Fifth Edition - September 1998, Table 1.4-3. Emission Factors For Speciated Organic Compounds From Natural Gas Combustion

Additional notes:

The average heating value for natural gas is used in these calculations (as provided in Section 1.4 of AP-42).

The PAH emission factor is a sum of all the constituent PAH emission factors in Table 1.4-3.

Medicine Bow Fuel & Power Industrial Gasification & Liquefaction Plant  
Preheater Detail Sheet

Source ID Number	Gasifier Preheater 3
Equipment Usage	Refractory Preheating
Equipment Make	TBD
Equipment Model	TBD
Serial Number	TBD
Installation Date	TBD
Emission Controls	None
Design Heat Rate	21.00 MMBtu/hr
<u>Cold Startup</u>	
Gas Heating Value	1020 Btu/scf
Gas Potential Operation	500 hr/yr
Gas Potential Fuel Usage	2.06E-02 MMscf/hr

Potential Emissions from Startup Operation (firing natural gas)

Pollutant	Emission Factor (lb/MMscf)	Estimated Emissions		Source of Emission Factor
		(lb/hr)	(tpy)	
NOx	50.00	1.03	0.26	AP-42 <sup>1</sup>
CO	84.00	1.73	0.43	AP-42 <sup>1</sup>
VOC	5.50	0.11	0.03	AP-42 <sup>2</sup>
SO2	0.60	0.01	3.09E-03	AP-42 <sup>2</sup>
PM10	7.60	0.16	0.04	AP-42 <sup>2</sup>
Benzene	2.1E-03	4.32E-05	1.08E-05	AP-42 <sup>3</sup>
Dichlorobenzene	1.2E-03	2.47E-05	6.18E-06	AP-42 <sup>3</sup>
Formaldehyde	7.5E-02	1.54E-03	3.86E-04	AP-42 <sup>3</sup>
Hexane	1.8E+00	3.71E-02	9.26E-03	AP-42 <sup>3</sup>
Toluene	3.4E-03	7.00E-05	1.75E-05	AP-42 <sup>3</sup>

<sup>1</sup> EPA AP-42, Volume I, Fifth Edition - September 1998, Table 1.4-1. Emission Factors for Nitrogen Oxides and Carbon Monoxide from Natural Gas Combustion

<sup>2</sup> EPA AP-42, Volume I, Fifth Edition - September 1998, Table 1.4-2. Emission Factors for Criteria Pollutants and Greenhouse Gases from Natural Gas Combustion

<sup>3</sup> EPA AP-42, Volume I, Fifth Edition - September 1998, Table 1.4-3. Emission Factors For Speciated Organic Compounds From Natural Gas Combustion

Additional notes:

The average heating value for natural gas is used in these calculations (as provided in Section 1.4 of AP-42).

The PAH emission factor is a sum of all the constituent PAH emission factors in Table 1.4-3.

**Medicine Bow Fuel & Power Industrial Gasification & Liquefaction Plant  
Preheater Detail Sheet**

Source ID Number	Gasifier Preheater 4
Equipment Usage	Refractory Preheating
Equipment Make	TBD
Equipment Model	TBD
Serial Number	TBD
Installation Date	TBD
Emission Controls	None
Design Heat Rate	21.00 MMBtu/hr
<u>Cold Startup</u>	
Gas Heating Value	1020 Btu/scf
Gas Potential Operation	500 hr/yr
Gas Potential Fuel Usage	2.06E-02 MMscf/hr

*Potential Emissions from Startup Operation (firing natural gas)*

Pollutant	Emission Factor (lb/MMscf)	Estimated Emissions		Source of Emission Factor
		(lb/hr)	(tpy)	
NOx	50.00	1.03	0.26	AP-42 <sup>1</sup>
CO	84.00	1.73	0.43	AP-42 <sup>1</sup>
VOC	5.50	0.11	0.03	AP-42 <sup>2</sup>
SO2	0.60	0.01	3.09E-03	AP-42 <sup>2</sup>
PM10	7.60	0.16	0.04	AP-42 <sup>2</sup>
Benzene	2.1E-03	4.32E-05	1.08E-05	AP-42 <sup>3</sup>
Dichlorobenzene	1.2E-03	2.47E-05	6.18E-06	AP-42 <sup>3</sup>
Formaldehyde	7.5E-02	1.54E-03	3.86E-04	AP-42 <sup>3</sup>
Hexane	1.8E+00	3.71E-02	9.26E-03	AP-42 <sup>3</sup>
Toluene	3.4E-03	7.00E-05	1.75E-05	AP-42 <sup>3</sup>

<sup>1</sup> EPA AP-42, Volume I, Fifth Edition - September 1998, Table 1.4-1. Emission Factors for Nitrogen Oxides and Carbon Monoxide from Natural Gas Combustion

<sup>2</sup> EPA AP-42, Volume I, Fifth Edition - September 1998, Table 1.4-2. Emission Factors for Criteria Pollutants and Greenhouse Gases from Natural Gas Combustion

<sup>3</sup> EPA AP-42, Volume I, Fifth Edition - September 1998, Table 1.4-3. Emission Factors For Speciated Organic Compounds From Natural Gas Combustion

Additional notes:

The average heating value for natural gas is used in these calculations (as provided in Section 1.4 of AP-42).

The PAH emission factor is a sum of all the constituent PAH emission factors in Table 1.4-3.

**Medicine Bow Fuel & Power Industrial Gasification & Liquefaction Plant  
Preheater Detail Sheet**

Source ID Number	Gasifier Preheater 5
Equipment Usage	Refractory Preheating
Equipment Make	TBD
Equipment Model	TBD
Serial Number	TBD
Installation Date	TBD
Emission Controls	None
Design Heat Rate	21.00 MMBtu/hr
<u>Cold Startup</u>	
Gas Heating Value	1020 Btu/scf
Gas Potential Operation	500 hr/yr
Gas Potential Fuel Usage	2.06E-02 MMscf/hr

*Potential Emissions from Startup Operation (firing natural gas)*

Pollutant	Emission Factor (lb/MMscf)	Estimated Emissions		Source of Emission Factor
		(lb/hr)	(tpy)	
NOx	50.00	1.03	0.26	AP-42 <sup>1</sup>
CO	84.00	1.73	0.43	AP-42 <sup>1</sup>
VOC	5.50	0.11	0.03	AP-42 <sup>2</sup>
SO2	0.60	0.01	3.09E-03	AP-42 <sup>2</sup>
PM10	7.60	0.16	0.04	AP-42 <sup>2</sup>
Benzene	2.1E-03	4.32E-05	1.08E-05	AP-42 <sup>3</sup>
Dichlorobenzene	1.2E-03	2.47E-05	6.18E-06	AP-42 <sup>3</sup>
Formaldehyde	7.5E-02	1.54E-03	3.86E-04	AP-42 <sup>3</sup>
Hexane	1.8E+00	3.71E-02	9.26E-03	AP-42 <sup>3</sup>
Toluene	3.4E-03	7.00E-05	1.75E-05	AP-42 <sup>3</sup>

<sup>1</sup> EPA AP-42, Volume I, Fifth Edition - September 1998, Table 1.4-1. Emission Factors for Nitrogen Oxides and Carbon Monoxide from Natural Gas Combustion

<sup>2</sup> EPA AP-42, Volume I, Fifth Edition - September 1998, Table 1.4-2. Emission Factors for Criteria Pollutants and Greenhouse Gases from Natural Gas Combustion

<sup>3</sup> EPA AP-42, Volume I, Fifth Edition - September 1998, Table 1.4-3. Emission Factors For Speciated Organic Compounds From Natural Gas Combustion

Additional notes:

The average heating value for natural gas is used in these calculations (as provided in Section 1.4 of AP-42).

The PAH emission factor is a sum of all the constituent PAH emission factors in Table 1.4-3.

Medicine Bow Fuel & Power Industrial Gasification & Liquefaction Plant  
Generator Detail Sheet

Source ID Number	Black-Start Generator 1		
Engine Usage	Startup Generators		
Engine Make	Caterpillar		
Engine Model	TBD		
Serial Number	TBD		
Installation Date	TBD		
Engine Configuration	Natural Gas		
Emission Controls	None		
Design Rating	1650	ekW	
Site Rated Horsepower	2889	BHP	
Fuel Heating Value	1020	Btu/scf	
Heat Rate	19.49	MMBtu/hr	
Engine Heat Rate	6748	Btu/hp-hr	
Potential Operation	250	hr/yr	
Potential Fuel Usage	4.78	MMscf/yr	At 100% load (worst case emissions)

Potential Emissions

Pollutant	Emission Factor		Estimated Emissions		Source of Emission Factor
	(lb/MMBtu)	(g/hp-hr)	(lb/hr)	(tpy)	
NOx		1	6.37	0.80	Manf. Data <sup>1</sup>
CO		2.43	15.48	1.93	Manf. Data <sup>1</sup>
VOC		0.9	5.73	0.72	Manf. Data <sup>1</sup>
SO2	0.000588		0.0115	0.001	AP-42 <sup>2</sup>
PM10 Total	0.000077		0.0015	0.00019	AP-42 <sup>2</sup>
1,3-Butadiene	2.67E-04		5.21E-03	6.51E-04	AP-42 <sup>2</sup>
2,2,4-Trimethylpentane	2.50E-04		4.87E-03	6.09E-04	AP-42 <sup>2</sup>
Acetaldehyde	8.36E-03		1.63E-01	2.04E-02	AP-42 <sup>2</sup>
Acrolein	5.14E-03		1.00E-01	1.25E-02	AP-42 <sup>2</sup>
Benzene	4.40E-04		8.58E-03	1.07E-03	AP-42 <sup>2</sup>
Biphenyl	2.12E-04		4.13E-03	5.17E-04	AP-42 <sup>2</sup>
Ethylbenzene	3.97E-05		7.74E-04	9.67E-05	AP-42 <sup>2</sup>
Formaldehyde	5.28E-02		1.03E+00	1.29E-01	AP-42 <sup>2</sup>
Methanol	2.50E-03		4.87E-02	6.09E-03	AP-42 <sup>2</sup>
n-Hexane	1.11E-04		2.16E-03	2.70E-04	AP-42 <sup>2</sup>
Toluene	4.08E-04		7.95E-03	9.94E-04	AP-42 <sup>2</sup>
Xylene	1.84E-04		3.59E-03	4.48E-04	AP-42 <sup>2</sup>

<sup>1</sup> Manufacturers Specification.

<sup>2</sup> EPA AP-42, Volume I, Fifth Edition - October 1996, Table 3.2-2, Uncontrolled Emission Factors for 4-Stroke Lean-Burn Engines.

Medicine Bow Fuel & Power Industrial Gasification & Liquefaction Plant  
Generator Detail Sheet

Source ID Number	Black-Start Generator 2	
Engine Usage	Startup Generators	
Engine Make	Caterpillar	
Engine Model	TBD	
Serial Number	TBD	
Installation Date	TBD	
Engine Configuration	Natural Gas	
Emission Controls	None	
Design Rating	1650	ekW
Site Rated Horsepower	2889	BHP
Fuel Heating Value	1020	Btu/scf
Heat Rate	19.49	MMBtu/hr
Engine Heat Rate	6748	Btu/hp-hr
Potential Operation	250	hr/yr
Potential Fuel Usage	4.78	MMscf/yr

At 100% load (worst case emissions)

Potential Emissions

Pollutant	Emission Factor		Estimated Emissions		Source of Emission Factor
	(lb/MMBtu)	(g/hp-hr)	(lb/hr)	(tpy)	
NOx		1	6.37	0.80	Manf. Data <sup>1</sup>
CO		2.43	15.48	1.93	Manf. Data <sup>1</sup>
VOC		0.9	5.73	0.72	Manf. Data <sup>1</sup>
SO2	0.000588		0.0115	0.001	AP-42 <sup>2</sup>
PM10 Total	0.000077		0.0015	0.00019	AP-42 <sup>2</sup>
1,3-Butadiene	2.67E-04		5.21E-03	6.51E-04	AP-42 <sup>2</sup>
2,2,4-Trimethylpentane	2.50E-04		4.87E-03	6.09E-04	AP-42 <sup>2</sup>
Acetaldehyde	8.36E-03		1.63E-01	2.04E-02	AP-42 <sup>2</sup>
Acrolein	5.14E-03		1.00E-01	1.25E-02	AP-42 <sup>2</sup>
Benzenes	4.40E-04		8.58E-03	1.07E-03	AP-42 <sup>2</sup>
Biphenyl	2.12E-04		4.13E-03	5.17E-04	AP-42 <sup>2</sup>
Ethylbenzene	3.97E-05		7.74E-04	9.67E-05	AP-42 <sup>2</sup>
Formaldehyde	5.28E-02		1.03E+00	1.29E-01	AP-42 <sup>2</sup>
Methanol	2.50E-03		4.87E-02	6.09E-03	AP-42 <sup>2</sup>
n-Hexane	1.11E-04		2.16E-03	2.70E-04	AP-42 <sup>2</sup>
Toluene	4.08E-04		7.95E-03	9.94E-04	AP-42 <sup>2</sup>
Xylene	1.84E-04		3.59E-03	4.48E-04	AP-42 <sup>2</sup>

<sup>1</sup> Manufacturers Specification.

<sup>2</sup> EPA AP-42, Volume 1, Fifth Edition - October 1996, Table 3.2-2, Uncontrolled Emission Factors for 4-Stroke Lean-Burn Engines.

**Medicine Bow Fuel & Power Industrial Gasification & Liquefaction Plant  
Generator Detail Sheet**

Source ID Number	Black-Start Generator 3	
Engine Usage	Startup Generators	
Engine Make	Caterpillar	
Engine Model	TBD	
Serial Number	TBD	
Installation Date	TBD	
Engine Configuration	Natural Gas	
Emission Controls	None	
Design Rating	1650	ekW
Site Rated Horsepower	2889	BHP
Fuel Heating Value	1020	Btu/scf
Heat Rate	19.49	MMBtu/hr
Engine Heat Rate	6748	Btu/hp-hr
Potential Operation	250	hr/yr
Potential Fuel Usage	4.78	MMscf/yr

At 100% load (worst case emissions)

*Potential Emissions*

Pollutant	Emission Factor		Estimated Emissions		Source of Emission Factor
	(lb/MMBtu)	(g/hp-hr)	(lb/hr)	(tpy)	
NOx		1	6.37	0.79615	Manf. Data <sup>1</sup>
CO		2.43	15.48	1.93464	Manf. Data <sup>1</sup>
VOC		0.9	5.73	0.71653	Manf. Data <sup>1</sup>
SO <sub>2</sub>	0.000588		0.0115	0.001	AP-42 <sup>2</sup>
PM10 Total	0.000077		0.0015	0.00019	AP-42 <sup>2</sup>
1,3-Butadiene	2.67E-04		5.21E-03	6.51E-04	AP-42 <sup>2</sup>
2,2,4-Trimethylpentane	2.50E-04		4.87E-03	6.09E-04	AP-42 <sup>2</sup>
Acetaldehyde	8.36E-03		1.63E-01	2.04E-02	AP-42 <sup>2</sup>
Acrolein	5.14E-03		1.00E-01	1.25E-02	AP-42 <sup>2</sup>
Benzene	4.40E-04		8.58E-03	1.07E-03	AP-42 <sup>2</sup>
Biphenyl	2.12E-04		4.13E-03	5.17E-04	AP-42 <sup>2</sup>
Ethylbenzene	3.97E-05		7.74E-04	9.67E-05	AP-42 <sup>2</sup>
Formaldehyde	5.28E-02		1.03E+00	1.29E-01	AP-42 <sup>2</sup>
Methanol	2.50E-03		4.87E-02	6.09E-03	AP-42 <sup>2</sup>
n-Hexane	1.11E-04		2.16E-03	2.70E-04	AP-42 <sup>2</sup>
Toluene	4.08E-04		7.95E-03	9.94E-04	AP-42 <sup>2</sup>
Xylene	1.84E-04		3.59E-03	4.48E-04	AP-42 <sup>2</sup>

<sup>1</sup> Manufacturers Specification.

<sup>2</sup> EPA AP-42, Volume I, Fifth Edition - October 1996, Table 3.2-2, Uncontrolled Emission Factors for 4-Stroke Lean-Burn Engines.

**Medicine Bow Fuel & Power Industrial Gasification & Liquefaction Plant  
Engine Detail Sheet**

Source ID Number	Firewater Pump
Engine Usage	Firewater Pump Engine
Engine Make	TBD
Engine Model	TBD
Serial Number	TBD
Installation Date	TBD
Engine Configuration	Fuel Oil
Emission Controls	None
Design Rating	575 BHP
Fuel Heating Value	18300 Btu/lb
Fuel Density	7.34 lb/gal
Heat Rate	3.85 MMBtu/hr
Potential Operation	500 hr/yr
Potential Fuel Usage	28.70 gal/hr

*Potential Emissions from Fuel Oil Operation*

Pollutant	Emission Factor		Estimated Emissions		Source of Emission Factor
	(lb/MMBtu)	(g/hp-hr)	(lb/hr)	(tpy)	
NOx		4.75	6.02	1.51	Vendor <sup>1</sup>
CO		0.29	0.37	0.09	Vendor <sup>1</sup>
VOC	0.35		1.35	0.34	AP-42 <sup>2</sup>
SO <sub>2</sub>			6.06E-03	1.52E-03	Eng. Est. <sup>3</sup>
PM10 Total		0.06	7.61E-02	0.02	Vendor <sup>1</sup>
1,3-Butadiene	3.91E-05		1.51E-04	3.77E-05	AP-42 <sup>4</sup>
Acetaldehyde	7.67E-04		2.96E-03	7.39E-04	AP-42 <sup>4</sup>
Acrolein	9.25E-05		3.57E-04	8.91E-05	AP-42 <sup>4</sup>
Benzene	9.33E-04		3.60E-03	8.99E-04	AP-42 <sup>4</sup>
Formaldehyde	1.18E-03		4.55E-03	1.14E-03	AP-42 <sup>4</sup>
Naphthalene	8.48E-05		3.27E-04	8.17E-05	AP-42 <sup>4</sup>
Propylene	2.58E-03		9.94E-03	2.49E-03	AP-42 <sup>4</sup>
Toluene	4.09E-04		1.58E-03	3.94E-04	AP-42 <sup>4</sup>
Xylene	2.85E-04		1.10E-03	2.75E-04	AP-42 <sup>4</sup>
<b>Total HAPs</b>			<b>2.46E-02</b>	<b>6.14E-03</b>	

<sup>1</sup> NOx, PM, and CO emissions are estimated based on vendor specifications.

<sup>2</sup> EPA AP-42, Volume I, Fifth Edition - October 1996, Table 3.3-1, Emission Factors for Uncontrolled Gasoline and Diesel Industrial Engines.

<sup>3</sup> SO<sub>2</sub> emissions are estimated based on 15 ppm S and assuming that 100% of S is converted to SO<sub>2</sub>.

<sup>4</sup> EPA AP-42, Volume I, Fifth Edition - October 1996, Table 3.3-2, Speciated Organic Compound Emission Factors for Uncontrolled Diesel Engines.



Madison Bow Fun & Power Industrial Gasification & Liquefaction Plant  
 Tank Detail Sheet

Potential VOC Emissions

Source ID	Source Name	Tank Capacity (gal)	Annual Throughput (gal/yr)	Product	Total VOC Emissions (lb/yr)	VOC Emission Rates		HAP Emission Rates						TOTAL	
						(lb/hr)	(tpy)	Hexane (lb/yr)	Benzene (lb/yr)	Toluene (lb/yr)	Ethylbenzene (lb/yr)	Xylene (cm) (lb/yr)	Methanol (lb/yr)	(lb/yr)	(tpy)
TBD	Slops Tank	7,800	42,000	Misc.	808.6	0.07	0.3	18.83	4.89	4.24	0.33	1.39	0	30.30	0.0
TBD	Methanol Tank #1	8,341,984	25,987,938	Methanol	2,285	0.25	1.1	0	0	0	0	0	2,285	2284.56	1.1
TBD	Methanol Tank #2	8,341,984	25,987,938	Methanol	2,285	0.25	1.1	0	0	0	0	0	2,285	2284.56	1.1
TBD	Gasoline Product #1	8,341,984	36,254,859	Product Gasoline	23,511	2.68	11.8	110.01	118.82	128.05	8.54	35.88	0	401.40	0.2
TBD	Gasoline Product #2	8,341,984	36,254,859	Product Gasoline	23,511	2.68	11.8	110.01	118.82	128.05	8.54	35.88	0	401.40	0.2
TBD	Gasoline Product #3	8,341,984	36,254,859	Product Gasoline	23,511	2.68	11.8	110.01	118.82	128.05	8.54	35.88	0	401.40	0.2
TBD	Gasoline Product #4	8,341,984	36,254,859	Product Gasoline	23,511	2.68	11.8	110.01	118.82	128.05	8.54	35.88	0	401.40	0.2
TBD	Gasoline Product #5	8,341,984	36,254,859	Product Gasoline	23,511	2.68	11.8	110.01	118.82	128.05	8.54	35.88	0	401.40	0.2
TBD	Gasoline Product #6	8,341,984	36,254,859	Product Gasoline	23,511	2.68	11.8	110.01	118.82	128.05	8.54	35.88	0	401.40	0.2
TBD	Gasoline Product #7	8,341,984	36,254,859	Product Gasoline	23,511	2.68	11.8	110.01	118.82	128.05	8.54	35.88	0	401.40	0.2
TBD	Gasoline Product #8	8,341,984	36,254,859	Product Gasoline	23,511	2.68	11.8	110.01	118.82	128.05	8.54	35.88	0	401.40	0.2
TBD	Heavy Gasoline Tank	4,783,841	36,781,340	Heavy Gasoline	9,837	1.10	4.8	80.68	87.32	94.76	6.48	27.56	0	297.01	0.1
TBD	Methanol Off-Spec Tank	8,000	30,000	Methanol	208	0.02	0.1	0	0	0	0	0	208.88	208.88	0.1
TBD	Gasoline Off-Spec Tank	8,000	30,000	Product Gasoline	2,148	0.24	1.1	10.01	10.8	11.43	0.72	3.04	0.00	38	0.0
<b>TOTAL</b>					<b>25.43</b>	<b>102.8</b>		<b>0.498316</b>	<b>0.628888</b>	<b>0.587418</b>	<b>0.037926</b>	<b>0.158918</b>	<b>2.38749</b>		<b>4.175</b>
											<b>HAP-Specific TPY</b>				

Notes:  
 All emissions were calculated using the EPA TANKS Program, version 4.09.d.  
 Annual hours of operation were assumed to be 8760.

Insignificant Emission Sources - Tanks

TBD	M/G Water Tank
TBD	Liquid Sulfur Storage Tank #1
TBD	Liquid Sulfur Storage Tank #2
03T-002	Slurry Water Tank
03T-003	Slurry Additive Tank
01T-104	Mill Discharge Tank
01T-105	Slurry Tank
02T-001	Inletor Coolant Tank
03T-001	Seller
03T-004	Filter Feed Tank
03T-005	Filter Tank
TBD	Glycol Storage Tank

Medicine Bow Fuel & Power Industrial Gasification & Liquefaction Plant  
 Arch Coal Company, Saddleback Hills Mine  
 BACT Option 1 (In-Pit Stacking Tubes) PM-10 Emissions

Emission Source	Type	Description	Control	Additional Information
Dozer Reclaim	Fugitive	Cat D11 Dozer	None	
		Emission Factor	8.0 Lb/Hr	WDEQ 2002 Guidance
		Total Throughput	3,200,000 Tons/Yr	Total Coal Through Storage
		Dozed Throughput	1,500,000 Tons/Yr	Portion to Dead Storage
		Dozer Productivity	750 Tons/Hr	Estimate for 300,000 Ton Pile
		Operating Hrs	2,000 Hrs	Productivity/Throughput
		TSP Emissions	8.00 Tons/Yr	$E=(EF \times Op\ Hrs)/2000$
		PM-10 Emissions	2.40 Tons/Yr	30% of TSP
Coal Stacker	Fugitive	Coal Dumping to Stockpile	Stacking Tubes	
		Emission Factor	0.017 Lb/Ton	WDEQ Emission Factor
		% Suspended	0.75	WDEQ Emission Factor
		Control Factor	50.00%	Estimated
		Material Dumped	3,200,000 Tons/Yr	Total Coal Through Storage
		TSP Emissions	10.20 Tons/Yr	$E=(EF \times \% \text{ sus} \times MD/2000) \times (1-CF)$
		PM-10 Emissions	3.06 Tons/Yr	30% of TSP
Coal Reclaim	Fugitive	Vibratory & Pile Activator Feeder	Passive Control	
		Emission Factor	0.017 Lb/Ton	WDEQ Emission Factor
		% Suspended	0.75	WDEQ Emission Factor
		Control Factor	100.00%	Estimated
		Material Reclaimed	3,200,000 Tons/Yr	Total Coal Through Storage
		TSP Emissions	0.00 Tons/Yr	$E=(EF \times \% \text{ sus} \times MR/2000) \times (1-CF)$
		PM-10 Emissions	0.00 Tons/Yr	30% of TSP
Coal Stockpile	Fugitive	Wind Erosion on Stockpiles	Water	
		Emission Factor	1.2 Lb/Acre/Hr	WDEQ Emission Factor
		Pile Size	11.0 Acres	Calculated from Pile Size
		Fraction Suspended	0.75	WDEQ Emission Factor
		Hours	8,760 Hours	Total Annual
		Ave. Wind Speed	5.03 meters/Sec	Adjusted for in-pit
		Wet Days	60	Seminole Mine 5-Year Average
		Control Factor	0.00%	
		TSP Emissions	182.40 Tons/Yr	$E=(EF \times AWS \times \% \text{ sus} \times PS \times ((365-WD)/365) \times (1-CF))/2000$
PM-10 Emissions	54.72 Tons/Yr			
<b>TOTAL PM-10 EMISSIONS</b>			<b>60.2 Tons/Yr</b>	

Medicine Bow Fuel & Power Industrial Gasification & Liquefaction Plant  
 Equipment Leaks Emission Summary

Process Stream	Service Type	Controlled Emissions		Uncontrolled Emissions	
		SOCMI Factors		SOCMI Factors	
		VOC Emissions (ton/yr)	HAP Emissions (ton/yr)	VOC Emissions (ton/yr)	HAP Emissions (ton/yr)
Acid Gas	Gas	0.09	0.09	0.12	0.12
Flare KO Drum Drainage	Gas	4.99	1.61	6.70	2.16
Gasifier Vent	Gas	0.16	0.16	0.22	0.22
Gasoline (Gas)	Gas	9.87	3.18	12.38	3.99
Gasoline (Light Liquid)	Light Liquid	17.12	5.52	36.22	11.67
Gasoline (Heavy Liquid)	Heavy Liquid	0.26	0.09	0.26	0.09
LPG	Light Liquid	1.12	0.00	2.21	0.00
Methanol Gas	Gas	1.04	1.04	1.28	1.28
Methanol Pure Liquid	Light Liquid	0.65	0.65	1.44	1.44
Methanol Product (MeOH 1)	Light Liquid	7.86	7.85	14.90	14.86
Methanol Product (MeOH 2)	Light Liquid	0.23	0.23	0.54	0.54
Methanol Product (MeOH 3)	Light Liquid	0.23	0.23	0.54	0.54
Methanol Product (MeOH 5)	Gas	0.40	0.40	0.50	0.50
Mixed Fuel Gas	Gas	0.52	0.02	1.77	0.06
MTG Fuel Gas	Gas	4.42	0.05	5.44	0.06
Propylene	Gas	22.35	0.00	24.36	0.00
<b>Total</b>		<b>71.32</b>	<b>21.10</b>	<b>108.86</b>	<b>37.52</b>

Individual HAPs	Controlled Emissions		Uncontrolled Emissions	
	SOCMI Factors		SOCMI Factors	
	HAP Emissions (lb/hr)	HAP Emissions (ton/yr)	HAP Emissions (lb/hr)	HAP Emissions (ton/yr)
Carbonyl Sulfide (COS)	0.06	0.26	0.08	0.35
Methanol (MeOH)	2.37	10.40	4.39	19.22
C6 - C10 Aromatics (Assumed to be Benzene)	2.38	10.44	4.10	17.96
<b>Total</b>	<b>4.82</b>	<b>21.10</b>	<b>8.57</b>	<b>37.52</b>

Medicine Bow Fuel & Power Industrial Gasification & Liquefaction Plant  
Controlled HAP Summary

Controlled Emissions (SOCMI Factors)

Process Stream	COS		MeOH		Benzene*	
	(lb/hr)	(ton/yr)	(lb/hr)	(ton/yr)	(lb/hr)	(ton/yr)
Acid Gas	2.13E-02	9.34E-02	0.00E+00	0.00E+00	0.00E+00	0.00E+00
Flare KO Drum Drainage	1.29E-03	5.66E-03	0.00E+00	0.00E+00	3.67E-01	1.61E+00
Gasifier Vent	3.67E-02	1.61E-01	0.00E+00	0.00E+00	0.00E+00	0.00E+00
Gasoline (Gas)	0.00E+00	0.00E+00	0.00E+00	0.00E+00	7.26E-01	3.18E+00
Gasoline (Light Liquid)	0.00E+00	0.00E+00	0.00E+00	0.00E+00	1.26E+00	5.52E+00
Gasoline (Heavy Liquid)	0.00E+00	0.00E+00	0.00E+00	0.00E+00	1.94E-02	8.51E-02
LPG	0.00E+00	0.00E+00	0.00E+00	0.00E+00	0.00E+00	0.00E+00
Methanol Gas	0.00E+00	0.00E+00	2.36E-01	1.04E+00	0.00E+00	0.00E+00
Methanol Pure Liquid	0.00E+00	0.00E+00	1.48E-01	6.50E-01	0.00E+00	0.00E+00
Methanol Product (MeOH 1)	0.00E+00	0.00E+00	1.79E+00	7.85E+00	0.00E+00	0.00E+00
Methanol Product (MeOH 2)	0.00E+00	0.00E+00	5.21E-02	2.28E-01	0.00E+00	0.00E+00
Methanol Product (MeOH 3)	0.00E+00	0.00E+00	5.19E-02	2.27E-01	0.00E+00	0.00E+00
Methanol Product (MeOH 5)	0.00E+00	0.00E+00	9.03E-02	3.95E-01	0.00E+00	0.00E+00
Mixed Fuel Gas	0.00E+00	0.00E+00	4.23E-03	1.85E-02	0.00E+00	0.00E+00
MTG Fuel Gas	0.00E+00	0.00E+00	0.00E+00	0.00E+00	1.15E-02	5.03E-02
Propylene	0.00E+00	0.00E+00	0.00E+00	0.00E+00	0.00E+00	0.00E+00
<b>Total</b>	<b>5.94E-02</b>	<b>2.60E-01</b>	<b>2.37E+00</b>	<b>1.04E+01</b>	<b>2.38E+00</b>	<b>1.04E+01</b>

\* Benzene is assumed from emissions of C6-C10 aromatics.

Uncontrolled HAP Summary

Uncontrolled Emissions (SOCMI Factors)

Process Stream	COS		MeOH		Benzene*	
	(lb/hr)	(ton/yr)	(lb/hr)	(ton/yr)	(lb/hr)	(ton/yr)
Acid Gas	2.79E-02	1.22E-01	0.00E+00	0.00E+00	0.00E+00	0.00E+00
Flare KO Drum Drainage	1.73E-03	7.59E-03	0.00E+00	0.00E+00	4.92E-01	2.15E+00
Gasifier Vent	4.92E-02	2.15E-01	0.00E+00	0.00E+00	0.00E+00	0.00E+00
Gasoline (Gas)	0.00E+00	0.00E+00	0.00E+00	0.00E+00	9.10E-01	3.99E+00
Gasoline (Light Liquid)	0.00E+00	0.00E+00	0.00E+00	0.00E+00	2.66E+00	1.17E+01
Gasoline (Heavy Liquid)	0.00E+00	0.00E+00	0.00E+00	0.00E+00	1.94E-02	8.51E-02
LPG	0.00E+00	0.00E+00	0.00E+00	0.00E+00	0.00E+00	0.00E+00
Methanol Gas	0.00E+00	0.00E+00	2.92E-01	1.28E+00	0.00E+00	0.00E+00
Methanol Pure Liquid	0.00E+00	0.00E+00	3.28E-01	1.44E+00	0.00E+00	0.00E+00
Methanol Product (MeOH 1)	0.00E+00	0.00E+00	3.39E+00	1.49E+01	0.00E+00	0.00E+00
Methanol Product (MeOH 2)	0.00E+00	0.00E+00	1.23E-01	5.40E-01	0.00E+00	0.00E+00
Methanol Product (MeOH 3)	0.00E+00	0.00E+00	1.23E-01	5.38E-01	0.00E+00	0.00E+00
Methanol Product (MeOH 5)	0.00E+00	0.00E+00	1.15E-01	5.02E-01	0.00E+00	0.00E+00
Mixed Fuel Gas	0.00E+00	0.00E+00	1.44E-02	6.32E-02	0.00E+00	0.00E+00
MTG Fuel Gas	0.00E+00	0.00E+00	0.00E+00	0.00E+00	1.41E-02	6.18E-02
Propylene	0.00E+00	0.00E+00	0.00E+00	0.00E+00	0.00E+00	0.00E+00
<b>Total</b>	<b>7.88E-02</b>	<b>3.45E-01</b>	<b>4.39E+00</b>	<b>1.92E+01</b>	<b>4.10E+00</b>	<b>1.80E+01</b>

\* Benzene is assumed from emissions of C6-C10 aromatics.

Medicine Bow Fuel & Power Industrial Gastication & Liquefaction Plant  
Acid Gas Process Stream

Stream Name: Acid Gas  
Service Type: Gas  
Hours of Operation: 8760  
This piping is included in the LDAR program.

Chemical Name	CAS Number	VOC	HAP	Molecular Weight (lb/lb-mol)	Weight %	Mole Fraction	Mole Percent
CO	630-08-0	N	N	28.01	0.00%	0.00E+00	0.00%
H2	1333-74-0	N	N	2.02	0.00%	0.00E+00	0.00%
CO2	124-38-6	N	N	44.01	55.84%	1.27E-02	47.86%
H2O	7732-18-6	N	N	18.02	3.37%	1.87E-03	7.05%
CH4	74-82-8	N	N	16.04	0.00%	0.00E+00	0.00%
Ar	7440-37-1	N	N	39.85	0.00%	0.00E+00	0.00%
N2	7727-37-9	N	N	28.01	0.00%	0.00E+00	0.00%
H2S	7783-06-4	N	N	34.08	40.16%	1.18E-02	44.37%
CO	463-58-1	Y	Y	60.07	0.28%	4.68E-05	0.18%
NH3	7664-41-7	N	N	17.03	0.25%	1.45E-04	0.55%
O2	7782-44-7	N	N	32.00	0.00%	0.00E+00	0.00%
SO2	7446-09-5	N	N	64.06	0.00%	0.00E+00	0.00%
Cl2	7782-50-5	N	Y	70.91	0.00%	0.00E+00	0.00%
HCl	7647-01-0	N	Y	36.48	0.00%	0.00E+00	0.00%
MeOH	67-56-1	Y	Y	32.04	0.00%	0.00E+00	0.00%
Ethanol	64-17-5	Y	N	46.07	0.00%	0.00E+00	0.00%
Dimethyl Ether	115-10-6	Y	N	46.07	0.00%	0.00E+00	0.00%
Methyl Acetate	79-20-9	Y	N	74.08	0.00%	0.00E+00	0.00%
Propanol	71-23-8	Y	N	60.10	0.00%	0.00E+00	0.00%
Butanol	71-36-3	Y	N	74.12	0.00%	0.00E+00	0.00%
Acetone	67-64-1	Y	N	58.08	0.00%	0.00E+00	0.00%
MEK	78-93-3	Y	N	72.11	0.00%	0.00E+00	0.00%
Ethane	74-84-0	N	N	30.07	0.00%	0.00E+00	0.00%
Ethylene	74-86-1	Y	N	28.05	0.00%	0.00E+00	0.00%
Propane	74-98-6	Y	N	44.10	0.00%	0.00E+00	0.00%
Propylene	115-07-1	Y	N	42.08	0.00%	0.00E+00	0.00%
Isobutane	75-28-5	Y	N	58.12	0.00%	0.00E+00	0.00%
N-Butane	106-97-8	Y	N	58.12	0.00%	0.00E+00	0.00%
Butylene	26167-67-3	Y	N	56.11	0.00%	0.00E+00	0.00%
Isopentane	78-78-4	Y	N	72.15	0.00%	0.00E+00	0.00%
C4 - C12 Paraffins	N/A	Y	N	114.23	0.00%	0.00E+00	0.00%
C4 - C12 Olefins	N/A	Y	N	112.21	0.00%	0.00E+00	0.00%
C6 - C10 Naphthenes	N/A	Y	N	112.21	0.00%	0.00E+00	0.00%
C6 - C10 Aromatics	N/A	Y	Y	78.11	0.00%	0.00E+00	0.00%
TOTALS					100.00%	2.66E-02	100.00%

Assumed Olefins  
Assumed Olefins  
Assumed Cycloolefins  
Assumed Benzene

Weight % TOC	0.28%
Weight % VOC	0.28%
Weight % HAP	0.28%

Fugitive Emissions - SOCM1 Factors				Controlled Emissions			Uncontrolled Emissions	
Equipment Type	SOCM1 Emission Factor <sup>1</sup> (kg/hr-source)	% Control With LDAR <sup>2</sup>	Source Count	TOC Emission Rate (kg/hr)	VOC Emission Rate (kg/hr)	Hours of Operation	VOC Emissions (tpy)	VOC Emissions (tpy)
Valves-Gas	0.00587	87.00%	204	0.0004	0.0004	8760	4.30E-03	3.30E-02
Valves-Light Liquids	0.00403	84.00%	0	0.0000	0.0000	8760	0.00E+00	0.00E+00
Valves-Heavy Liquids	0.00023		0	0.0000	0.0000	8760	0.00E+00	0.00E+00
Pump Seals-Light Liquids	0.01880	69.00%	0	0.0000	0.0000	8760	0.00E+00	0.00E+00
Pump Seals-Heavy Liquids	0.00882		0	0.0000	0.0000	8760	0.00E+00	0.00E+00
Compressor Seals-Gas	0.22800		0	0.0000	0.0000	8760	0.00E+00	0.00E+00
Relief Valves-Gas/Vapor	0.10400		27	0.0079	0.0079	8760	7.62E-02	7.62E-02
Connectors	0.00183		130	0.0007	0.0007	8760	6.45E-03	6.45E-03
Open-ended Lines	0.00170		0	0.0000	0.0000	8760	0.00E+00	0.00E+00
Sampling Connections	0.01500		16	0.0007	0.0007	8760	6.51E-03	6.51E-03
Totals				0.01	0.01		0.09	0.12

<sup>1</sup> EPA-453/R-95-017 Protocol for Equipment Leak Emission Estimates (Table 2-1).  
<sup>2</sup> EPA-453/R-95-017 Protocol for Equipment Leak Emission Estimates (Table 5-2). Assumes monthly monitoring with leak definition of 10,000 ppmv.

HAP Emissions - SOCM1 Factors				Controlled Emissions		Uncontrolled Emissions	
HAP	Individual HAP Weight %	VOC Weight %	Hours of Operation	HAP Emissions (lb/hr)	HAP Emissions (ton/yr)	HAP Emissions (lb/hr)	HAP Emissions (ton/yr)
CO	0.28%	0.28%	8760	2.13E-02	8.34E-02	2.79E-02	1.22E-01
Cl2	0.00%	0.28%	8760	0.00E+00	0.00E+00	0.00E+00	0.00E+00
HCl	0.00%	0.28%	8760	0.00E+00	0.00E+00	0.00E+00	0.00E+00
MeOH	0.00%	0.28%	8760	0.00E+00	0.00E+00	0.00E+00	0.00E+00
C6 - C10 Aromatics	0.00%	0.28%	8760	0.00E+00	0.00E+00	0.00E+00	0.00E+00
Total				0.02	0.09	0.03	0.12

Medicine Bow Fuel & Power Industrial Gasification & Liquefaction Plant  
Flare KO Drum Drainage Process Stream

Stream Name: Flare KO Drum Drainage  
Service Type: Gas  
Hours of Operation: 8760  
This piping is included in the LDAR program.

Chemical Name	CAS Number	VOC	HAP	Molecular Weight (lb/lb-mol)	Weight %	Mole Fraction	Mole Percent
CO	630-08-0	N	N	28.01	22.46%	8.02E-03	29.34%
H2	1333-74-0	N	N	2.02	1.16%	5.77E-03	21.11%
CO2	124-38-9	N	N	44.01	18.13%	4.12E-03	15.08%
H2O	7732-18-5	N	N	18.02	7.50%	4.16E-03	15.23%
CH4	74-82-8	N	N	16.04	0.03%	2.05E-05	0.07%
Ar	7440-37-1	N	N	39.95	0.37%	9.29E-05	0.34%
N2	7727-37-9	N	N	28.01	0.12%	4.25E-05	0.16%
H2S	7783-06-4	N	N	34.08	0.16%	4.72E-05	0.17%
COS	463-58-1	Y	Y	60.07	0.06%	9.44E-06	0.03%
NH3	7664-41-7	N	N	17.03	0.01%	3.15E-06	0.01%
O2	7782-44-7	N	N	32.00	0.00%	0.00E+00	0.00%
SO2	7446-08-5	N	N	64.06	0.00%	0.00E+00	0.00%
Cl2	7782-50-5	N	Y	70.91	0.00%	0.00E+00	0.00%
HCl	7647-01-0	N	Y	36.46	0.00%	0.00E+00	0.00%
MeOH	67-56-1	Y	Y	32.04	0.00%	0.00E+00	0.00%
Ethanol	64-17-5	Y	N	46.07	0.00%	0.00E+00	0.00%
Dimethyl Ether	115-10-5	Y	N	46.07	0.00%	0.00E+00	0.00%
Methyl Acetate	79-20-9	Y	N	74.08	0.00%	0.00E+00	0.00%
Propanol	71-23-8	Y	N	60.10	0.00%	0.00E+00	0.00%
Butanol	71-36-3	Y	N	74.12	0.00%	0.00E+00	0.00%
Acetone	67-64-1	Y	N	58.08	0.00%	0.00E+00	0.00%
MEK	78-93-3	Y	N	72.11	0.00%	0.00E+00	0.00%
Ethane	74-84-0	N	N	30.07	0.00%	0.00E+00	0.00%
Ethylene	74-85-1	Y	N	28.05	0.00%	0.00E+00	0.00%
Propane	74-98-6	Y	N	44.10	0.00%	0.00E+00	0.00%
Propylene	115-07-1	Y	N	42.08	0.00%	0.00E+00	0.00%
Isobutane	76-28-5	Y	N	58.12	0.00%	0.00E+00	0.00%
N-Butane	106-97-8	Y	N	58.12	0.00%	0.00E+00	0.00%
Butylene	25167-57-3	Y	N	58.11	0.00%	0.00E+00	0.00%
Isopentane	78-78-4	Y	N	72.15	0.00%	0.00E+00	0.00%
C4 - C12 Paraffins	N/A	Y	N	114.23	23.93%	2.09E-03	7.86%
C4 - C12 Olefins	N/A	Y	N	112.21	4.20%	3.74E-04	1.37%
C6 - C10 Naphthenes	N/A	Y	N	112.21	5.77%	5.14E-04	1.89%
C6 - C10 Aromatics	N/A	Y	Y	78.11	16.11%	2.06E-03	7.54%
TOTALS					100.00%	2.73E-02	100.00%

Assumed Octane  
Assumed Octene  
Assumed Cyclooctane  
Assumed Benzene

Weight % TOC	50.09%
Weight % VOC	50.06%
Weight % HAP	16.16%

Fugitive Emissions - SOCM1 Factors				Controlled Emissions			Uncontrolled Emissions	
Equipment Type	SOCM1 Emission Factor <sup>1</sup> (kg/hr-source)	% Control With LDAR <sup>2</sup>	Source Count	TOC Emission Rate (kg/hr)	VOC Emission Rate (kg/hr)	Hours of Operation	VOC Emissions (tpy)	VOC Emissions (tpy)
Valves-Gas	0.00597	87.00%	68	0.0264	0.0264	8760	2.55E-01	1.96E+00
Valves-Light Liquids	0.00403	84.00%	0	0.0000	0.0000	8760	0.00E+00	0.00E+00
Valves-Heavy Liquids	0.00223		0	0.0000	0.0000	8760	0.00E+00	0.00E+00
Pump Seals-Light Liquids	0.01960	69.00%	0	0.0000	0.0000	8760	0.00E+00	0.00E+00
Pump Seals-Heavy Liquids	0.00862		0	0.0000	0.0000	8760	0.00E+00	0.00E+00
Compressor Seals-Gas	0.22800		0	0.0000	0.0000	8760	0.00E+00	0.00E+00
Relief Valves-Gas/Vapor	0.10400		8	0.4167	0.4165	8760	4.02E+00	4.02E+00
Connectors	0.00183		48	0.0440	0.0440	8760	4.24E-01	4.24E-01
Open-ended Lines	0.00170		0	0.0000	0.0000	8760	0.00E+00	0.00E+00
Sampling Connections	0.01500		4	0.0301	0.0300	8760	2.90E-01	2.90E-01
Totals				0.52	0.52		4.99	6.70

<sup>1</sup> EPA-453/R-95-017 Protocol for Equipment Leak Emission Estimates (Table 2-1).  
<sup>2</sup> EPA-453/R-95-017 Protocol for Equipment Leak Emission Estimates (Table 5-2). Assumes monthly monitoring with leak definition of 10,000 ppmv.

HAP Emissions - SOCM1 Factors				Controlled Emissions		Uncontrolled Emissions	
HAP	Individual HAP Weight %	VOC Weight %	Hours of Operation	HAP Emissions (lb/hr)	HAP Emissions (ton/yr)	HAP Emissions (lb/hr)	HAP Emissions (ton/yr)
COS	0.06%	50.06%	8760	1.29E-03	5.66E-03	1.73E-03	7.59E-03
Cl2	0.00%	50.06%	8760	0.00E+00	0.00E+00	0.00E+00	0.00E+00
HCl	0.00%	50.06%	8760	0.00E+00	0.00E+00	0.00E+00	0.00E+00
MeOH	0.00%	50.06%	8760	0.00E+00	0.00E+00	0.00E+00	0.00E+00
C6 - C10 Aromatics	16.11%	50.06%	8760	3.67E-01	1.61E+00	4.92E-01	2.15E+00
Total				0.37	1.61	0.49	2.16

Medicine Bow Fuel & Power Industrial Gasification & Liquefaction Plant  
Gasifier Vent Process Stream

Stream Name: Gasifier Vent  
Service Type: Gas  
Hours of Operation: 8760  
This piping is included in the LDAR program.

Chemical Name	CAS Number	VOC	HAP	Molecular Weight (lb/lb-mol)	Weight %	Mole Fraction	Mole Percent
CO	630-08-0	N	N	28.01	44.91%	1.80E-02	35.98%
H2	1333-74-0	N	N	2.02	2.33%	1.15E-02	25.89%
CO2	124-38-8	N	N	44.01	36.27%	8.24E-03	18.48%
H2O	7732-18-5	N	N	18.02	15.00%	8.33E-03	18.68%
CH4	74-82-8	N	N	16.04	0.07%	4.08E-05	0.08%
Ar	7440-37-1	N	N	39.95	0.74%	1.88E-04	0.42%
N2	7727-37-9	N	N	28.01	0.24%	8.50E-05	0.18%
H2S	7783-06-4	N	N	34.08	0.32%	9.45E-05	0.21%
COS	463-55-1	Y	Y	60.07	0.11%	1.89E-05	0.04%
NH3	7664-41-7	N	N	17.03	0.01%	6.50E-06	0.01%
O2	7782-44-7	N	N	32.00	0.00%	0.00E+00	0.00%
SO2	7445-09-5	N	N	64.06	0.00%	0.00E+00	0.00%
Cl2	7782-50-5	N	Y	70.91	0.00%	0.00E+00	0.00%
HCl	7647-01-0	N	Y	36.46	0.00%	0.00E+00	0.00%
MeOH	67-56-1	Y	Y	32.04	0.00%	0.00E+00	0.00%
Ethanol	64-17-5	Y	N	46.07	0.00%	0.00E+00	0.00%
Dimethyl Ether	115-10-6	Y	N	46.07	0.00%	0.00E+00	0.00%
Methyl Acetate	79-20-9	Y	N	74.08	0.00%	0.00E+00	0.00%
Propanol	71-23-8	Y	N	60.10	0.00%	0.00E+00	0.00%
Butanol	71-36-3	Y	N	74.12	0.00%	0.00E+00	0.00%
Acetone	67-64-1	Y	N	58.08	0.00%	0.00E+00	0.00%
MEK	78-93-3	Y	N	72.11	0.00%	0.00E+00	0.00%
Ethane	74-84-0	N	N	30.07	0.00%	0.00E+00	0.00%
Ethylene	74-85-1	Y	N	28.05	0.00%	0.00E+00	0.00%
Propane	74-98-6	Y	N	44.10	0.00%	0.00E+00	0.00%
Propylene	115-07-1	Y	N	42.08	0.00%	0.00E+00	0.00%
Isobutane	75-28-5	Y	N	58.12	0.00%	0.00E+00	0.00%
n-Butane	106-97-8	Y	N	58.12	0.00%	0.00E+00	0.00%
Butylene	26167-87-3	Y	N	56.11	0.00%	0.00E+00	0.00%
Isopentane	78-78-4	Y	N	72.15	0.00%	0.00E+00	0.00%
C4 - C12 Paraffins	N/A	Y	N	114.23	0.00%	0.00E+00	0.00%
C4 - C12 Olefins	N/A	Y	N	112.21	0.00%	0.00E+00	0.00%
C6 - C10 Naphthenes	N/A	Y	N	112.21	0.00%	0.00E+00	0.00%
C6 - C10 Aromatics	N/A	Y	Y	78.11	0.00%	0.00E+00	0.00%
TOTALS					100.00%	4.45E-02	100.00%

Assumed Octane  
Assumed Cyclohexane  
Assumed Benzene

Weight % TOC	0.18%
Weight % VOC	0.11%
Weight % HAP	0.11%

Fugitive Emissions - SOCM1 Factors				Controlled Emissions				Uncontrolled Emissions
Equipment Type	SOCM1 Emission Factor <sup>1</sup> (kg/hr-source)	% Control With LDAR <sup>2</sup>	Source Count	TOC Emission Rate (kg/hr)	VOC Emission Rate (kg/hr)	Hours of Operation	VOC Emissions (tpy)	VOC Emissions (tpy)
Valves-Gas	0.00597	87.00%	957	0.0013	0.0008	8760	8.14E-03	6.26E-02
Valves-Light Liquids	0.00403	64.00%	0	0.0000	0.0000	8760	0.00E+00	0.00E+00
Valves-Heavy Liquids	0.00023		0	0.0000	0.0000	8760	0.00E+00	0.00E+00
Pump Seals-Light Liquids	0.01990	89.00%	0	0.0000	0.0000	8760	0.00E+00	0.00E+00
Pump Seals-Heavy Liquids	0.00982		0	0.0000	0.0000	8760	0.00E+00	0.00E+00
Compressor Seals-Gas	0.22800		0	0.0000	0.0000	8760	0.00E+00	0.00E+00
Relief Valves-Gas/Vapor	0.10400		112	0.0209	0.0132	8760	1.28E-01	1.28E-01
Connectors	0.00183		804	0.0026	0.0017	8760	1.61E-02	1.61E-02
Open-ended Lines	0.00170		0	0.0000	0.0000	8760	0.00E+00	0.00E+00
Sampling Connections	0.01500		65	0.0015	0.0009	8760	9.04E-03	9.04E-03
Totals				0.03	0.02		0.16	0.22

<sup>1</sup> EPA-453/R-95-017 Protocol for Equipment Leak Emission Estimates (Table 2-1).  
<sup>2</sup> EPA-453/R-95-017 Protocol for Equipment Leak Emission Estimates (Table 5-2), Assumes monthly monitoring with leak definition of 10,000 ppmv.

HAP Emissions - SOCM1 Factors				Controlled Emissions		Uncontrolled Emissions	
HAP	Individual HAP Weight %	VOC Weight %	Hours of Operation	HAP Emissions (lb/hr)	HAP Emissions (ton/yr)	HAP Emissions (lb/hr)	HAP Emissions (ton/yr)
COS	0.11%	0.11%	8760	3.67E-02	1.61E-01	4.92E-02	2.15E-01
Cl2	0.00%	0.11%	8760	0.00E+00	0.00E+00	0.00E+00	0.00E+00
HCl	0.00%	0.11%	8760	0.00E+00	0.00E+00	0.00E+00	0.00E+00
MeOH	0.00%	0.11%	8760	0.00E+00	0.00E+00	0.00E+00	0.00E+00
C6 - C10 Aromatics	0.00%	0.11%	8760	0.00E+00	0.00E+00	0.00E+00	0.00E+00
Total				0.04	0.16	0.05	0.22

Medicine Bow Fuel & Power Industrial Gasification & Liquefaction Plant  
Gasoline (Gas) Process Stream

Stream Name: Gasoline (Gas)  
Service Type: Gas  
Hours of Operation: 8760  
This piping is included in the LDAR program.

Chemical Name	CAS Number	VOC	HAP	Molecular Weight (lb/lb-mol)	Weight %	Mole Fraction	Mole Percent
CO	630-08-0	N	N	28.01	0.00%	0.00E+00	0.00%
H2	1333-74-0	N	N	2.02	0.00%	0.00E+00	0.00%
CO2	124-38-9	N	N	44.01	0.00%	0.00E+00	0.00%
H2O	7732-18-5	N	N	18.02	0.00%	0.00E+00	0.00%
CH4	74-82-8	N	N	16.04	0.00%	0.00E+00	0.00%
Ar	7440-37-1	N	N	39.98	0.00%	0.00E+00	0.00%
N2	7727-37-9	N	N	28.01	0.00%	0.00E+00	0.00%
H2S	7783-06-4	N	N	34.08	0.00%	0.00E+00	0.00%
COS	463-58-1	Y	Y	60.07	0.00%	0.00E+00	0.00%
NH3	7664-41-7	N	N	17.03	0.00%	0.00E+00	0.00%
O2	7782-44-7	N	N	32.00	0.00%	0.00E+00	0.00%
SO2	7446-09-5	N	N	64.06	0.00%	0.00E+00	0.00%
Cl2	7782-50-5	N	Y	70.91	0.00%	0.00E+00	0.00%
HCl	7647-01-0	N	Y	36.46	0.00%	0.00E+00	0.00%
MeOH	67-58-1	Y	Y	32.04	0.00%	0.00E+00	0.00%
Ethanol	64-17-5	Y	N	46.07	0.00%	0.00E+00	0.00%
Dimethyl Ether	115-10-6	Y	N	46.07	0.00%	0.00E+00	0.00%
Methyl Acetate	79-20-9	Y	N	74.08	0.00%	0.00E+00	0.00%
Propanol	71-23-8	Y	N	60.10	0.00%	0.00E+00	0.00%
Butanol	71-36-3	Y	N	74.12	0.00%	0.00E+00	0.00%
Acetone	67-64-1	Y	N	58.08	0.00%	0.00E+00	0.00%
MEK	78-93-3	Y	N	72.11	0.00%	0.00E+00	0.00%
Ethane	74-84-0	N	N	30.07	0.00%	0.00E+00	0.00%
Ethylene	74-85-1	Y	N	28.05	0.00%	0.00E+00	0.00%
Propane	74-98-6	Y	N	44.10	0.00%	0.00E+00	0.00%
Propylene	115-07-1	Y	N	42.08	0.00%	0.00E+00	0.00%
Isobutane	75-28-5	Y	N	58.12	0.00%	0.00E+00	0.00%
N-Butane	106-97-8	Y	N	58.12	0.00%	0.00E+00	0.00%
Butylene	25187-57-3	Y	N	56.11	0.00%	0.00E+00	0.00%
Isopentane	78-78-4	Y	N	72.15	0.00%	0.00E+00	0.00%
C4 - C12 Paraffins	N/A	Y	N	114.23	47.85%	4.19E-03	41.52%
C4 - C12 Olefins	N/A	Y	N	112.21	8.39%	7.48E-04	7.41%
C6 - C10 Naphthenes	N/A	Y	N	112.21	11.54%	1.03E-03	10.19%
C6 - C10 Aromatics	N/A	Y	Y	78.11	32.21%	4.12E-03	40.87%
TOTALS					100.00%	1.01E-02	100.00%

Assumed Octane  
Assumed Octane  
Assumed Cyclooctane  
Assumed Benzene

Weight % TOC	100.00%
Weight % VOC	100.00%
Weight % HAP	32.21%

Fugitive Emissions - SOCM Factors				Controlled Emissions				Uncontrolled Emissions
Equipment Type	SOCM Factor <sup>1</sup> Emission Factor <sup>1</sup> (kg/hr-source)	% Control With LDAR <sup>2</sup>	Source Count	TOC Emission Rate (kg/hr)	VOC Emission Rate (kg/hr)	Hours of Operation	VOC Emissions (tpy)	VOC Emissions (tpy)
Valves-Gas	0.00697	87.00%	50	0.0388	0.0388	8760	3.75E-01	2.88E+00
Valves-Light Liquids	0.00403	84.00%	0	0.0000	0.0000	8760	0.00E+00	0.00E+00
Valves-Heavy Liquids	0.00023		0	0.0000	0.0000	8760	0.00E+00	0.00E+00
Pump Seals-Light Liquids	0.01990	69.00%	0	0.0000	0.0000	8760	0.00E+00	0.00E+00
Pump Seals-Heavy Liquids	0.00862		0	0.0000	0.0000	8760	0.00E+00	0.00E+00
Compressor Seals-Gas	0.22800		0	0.0000	0.0000	8760	0.00E+00	0.00E+00
Relief Valves-Gas/Vapor	0.10400		9	0.9360	0.9360	8760	9.04E+00	9.04E+00
Connectors	0.00183		28	0.0476	0.0476	8760	4.59E-01	4.59E-01
Open-ended Lines	0.00170		0	0.0000	0.0000	8760	0.00E+00	0.00E+00
Sampling Connections	0.01500		0	0.0000	0.0000	8760	0.00E+00	0.00E+00
Totals				1.02	1.02		9.87	12.38

<sup>1</sup> EPA-453/R-95-017 Protocol for Equipment Leak Emission Estimates (Table 2-1).  
<sup>2</sup> EPA-453/R-95-017 Protocol for Equipment Leak Emission Estimates (Table 5-2). Assumes monthly monitoring with leak definition of 10,000 ppmv.

HAP Emissions - SOCM Factors				Controlled Emissions		Uncontrolled Emissions	
HAP	Individual HAP Weight %	VOC Weight %	Hours of Operation	HAP Emissions (lb/hr)	HAP Emissions (ton/yr)	HAP Emissions (lb/hr)	HAP Emissions (ton/yr)
COS	0.00%	100.00%	8760	0.00E+00	0.00E+00	0.00E+00	0.00E+00
Cl2	0.00%	100.00%	8760	0.00E+00	0.00E+00	0.00E+00	0.00E+00
HCl	0.00%	100.00%	8760	0.00E+00	0.00E+00	0.00E+00	0.00E+00
MeOH	0.00%	100.00%	8760	0.00E+00	0.00E+00	0.00E+00	0.00E+00
C6 - C10 Aromatics	32.21%	100.00%	8760	7.26E-01	3.18E+00	9.10E-01	3.99E+00
Total				0.73	3.18	0.91	3.99



Medicine Bow Fuel & Power Industrial Gasification & Liquefaction Plant  
Gasoline (Light Liquid) Process Stream

Stream Name: Gasoline (Light Liquid)  
Service Type: Light Liquid  
Hours of Operation: 8760  
This piping is included in the LDAR program.

Chemical Name	CAS Number	VOC	HAP	Molecular Weight (lb/lb-mol)	Weight %	Mole Fraction	Mole Percent
CO	630-08-0	N	N	28.01	0.00%	0.00E+00	0.00%
H2	1333-74-0	N	N	2.02	0.00%	0.00E+00	0.00%
CO2	124-38-9	N	N	44.01	0.00%	0.00E+00	0.00%
H2O	7732-18-5	N	N	18.02	0.00%	0.00E+00	0.00%
CH4	74-82-8	N	N	16.04	0.00%	0.00E+00	0.00%
Ar	7440-37-1	N	N	39.95	0.00%	0.00E+00	0.00%
N2	7727-37-9	N	N	28.01	0.00%	0.00E+00	0.00%
H2S	7783-06-4	N	N	34.08	0.00%	0.00E+00	0.00%
COS	463-58-1	Y	Y	60.07	0.00%	0.00E+00	0.00%
NH3	7664-41-7	N	N	17.03	0.00%	0.00E+00	0.00%
O2	7782-44-7	N	N	32.00	0.00%	0.00E+00	0.00%
SO2	7446-09-5	N	N	64.06	0.00%	0.00E+00	0.00%
Cl2	7782-50-5	N	Y	70.91	0.00%	0.00E+00	0.00%
HCl	7647-01-0	N	Y	36.46	0.00%	0.00E+00	0.00%
MeOH	67-56-1	Y	Y	32.04	0.00%	0.00E+00	0.00%
Ethanol	64-17-5	Y	N	46.07	0.00%	0.00E+00	0.00%
Dimethyl Ether	115-10-5	Y	N	46.07	0.00%	0.00E+00	0.00%
Methyl Acetate	78-20-9	Y	N	74.08	0.00%	0.00E+00	0.00%
Propanol	71-23-8	Y	N	60.10	0.00%	0.00E+00	0.00%
Butanol	71-38-3	Y	N	74.12	0.00%	0.00E+00	0.00%
Acetone	67-64-1	Y	N	58.08	0.00%	0.00E+00	0.00%
MEK	78-93-3	Y	N	72.11	0.00%	0.00E+00	0.00%
Ethane	74-84-0	N	N	30.07	0.00%	0.00E+00	0.00%
Ethylene	74-85-1	Y	N	28.05	0.00%	0.00E+00	0.00%
Propane	74-98-6	Y	N	44.10	0.00%	0.00E+00	0.00%
Propylene	115-07-1	Y	N	42.08	0.00%	0.00E+00	0.00%
Isobutane	75-28-5	Y	N	58.12	0.00%	0.00E+00	0.00%
N-Butane	106-97-8	Y	N	58.12	0.00%	0.00E+00	0.00%
Butylene	25167-87-3	Y	N	56.11	0.00%	0.00E+00	0.00%
Isopentane	78-78-4	Y	N	72.15	0.00%	0.00E+00	0.00%
C4 - C12 Paraffins	N/A	Y	N	114.23	47.85%	4.19E-03	41.52%
C4 - C12 Olefins	N/A	Y	N	112.21	8.39%	7.48E-04	7.41%
C8 - C10 Naphthenes	N/A	Y	N	112.21	11.54%	1.03E-03	10.19%
C8 - C10 Aromatics	N/A	Y	Y	78.11	32.21%	4.12E-03	40.87%
TOTALS					100.00%	1.61E-02	100.00%

Assumed Octane  
Assumed Octane  
Assumed Cyclooctane  
Assumed Benzene

Weight % TOC	100.00%
Weight % VOC	100.00%
Weight % HAP	32.21%

Fugitive Emissions - SDCMI Factors				Controlled Emissions			Uncontrolled Emissions	
Equipment Type	SDCMI Emission Factor <sup>1</sup> (kg/hr-source)	% Control With LDAR <sup>2</sup>	Source Count	TOC Emission Rate (kg/hr)	VOC Emission Rate (kg/hr)	Hours of Operation	VOC Emissions (tpy)	VOC Emissions (tpy)
Valves-Gas	0.00597	87.00%	0	0.0000	0.0000	8760	0.00E+00	0.00E+00
Valves-Light Liquids	0.00403	84.00%	487	0.3140	0.3140	8760	3.03E+00	1.89E+01
Valves-Heavy Liquids	0.00023		0	0.0000	0.0000	8760	0.00E+00	0.00E+00
Pump Seals-Light Liquids	0.01980	89.00%	24	0.1481	0.1481	8760	1.43E+00	4.81E+00
Pump Seals-Heavy Liquids	0.00862		0	0.0000	0.0000	8760	0.00E+00	0.00E+00
Compressor Seals-Gas	0.22800		0	0.0000	0.0000	8760	0.00E+00	0.00E+00
Relief Valves-Gas/Vapor	0.10400		0	0.0000	0.0000	8760	0.00E+00	0.00E+00
Connectors	0.00183		348	0.6388	0.6388	8760	6.15E+00	6.15E+00
Open-ended Lines	0.00170		0	0.0000	0.0000	8760	0.00E+00	0.00E+00
Sampling Connections	0.01500		45	0.6750	0.6750	8760	6.52E+00	6.52E+00
Totals				1.77	1.77		17.12	36.22

<sup>1</sup> EPA-453/R-95-017 Protocol for Equipment Leak Emission Estimates (Table 2-1).

<sup>2</sup> EPA-453/R-95-017 Protocol for Equipment Leak Emission Estimates (Table 5-2). Assumes monthly monitoring with leak definition of 10,000 ppmv.

HAP Emissions - SDCMI Factors				Controlled Emissions		Uncontrolled Emissions	
HAP	Individual HAP Weight %	VOC Weight %	Hours of Operation	HAP Emissions (lb/hr)	HAP Emissions (ton/yr)	HAP Emissions (lb/hr)	HAP Emissions (ton/yr)
COS	0.00%	100.00%	8760	0.00E+00	0.00E+00	0.00E+00	0.00E+00
Cl2	0.00%	100.00%	8760	0.00E+00	0.00E+00	0.00E+00	0.00E+00
HCl	0.00%	100.00%	8760	0.00E+00	0.00E+00	0.00E+00	0.00E+00
MeOH	0.00%	100.00%	8760	0.00E+00	0.00E+00	0.00E+00	0.00E+00
C8 - C10 Aromatics	32.21%	100.00%	8760	1.28E+00	5.52E+00	2.56E+00	1.17E+01
Total				1.26	5.52	2.66	11.67

Medicine Bow Fuel & Power Industrial Gasification & Liquefaction Plant  
Gasoline (Heavy Liquid) Process Stream

Stream Name: Gasoline (Heavy Liquid)  
Service Type: Heavy Liquid  
Hours of Operation: 8760  
This piping is included in the LDAR program.

Chemical Name	CAS Number	VOC	HAP	Molecular Weight (lb/lb-mol)	Weight %	Mole Fraction	Mole Percent
CO	630-08-0	N	N	28.01	0.00%	0.00E+00	0.00%
H2	1333-74-0	N	N	2.02	0.00%	0.00E+00	0.00%
CO2	124-38-9	N	N	44.01	0.00%	0.00E+00	0.00%
H2O	7732-18-5	N	N	18.02	0.00%	0.00E+00	0.00%
CH4	74-82-9	N	N	16.04	0.00%	0.00E+00	0.00%
Ar	7440-37-1	N	N	39.95	0.00%	0.00E+00	0.00%
N2	7727-37-9	N	N	28.01	0.00%	0.00E+00	0.00%
H2S	7783-08-4	N	N	34.08	0.00%	0.00E+00	0.00%
COs	463-58-1	Y	Y	60.07	0.00%	0.00E+00	0.00%
NH3	7664-41-7	N	N	17.03	0.00%	0.00E+00	0.00%
O2	7782-44-7	N	N	32.00	0.00%	0.00E+00	0.00%
SO2	7446-09-5	N	N	64.06	0.00%	0.00E+00	0.00%
Cl2	7782-50-5	N	Y	70.91	0.00%	0.00E+00	0.00%
HCl	7647-01-0	N	Y	36.46	0.00%	0.00E+00	0.00%
MeOH	67-56-1	Y	Y	32.04	0.00%	0.00E+00	0.00%
Ethanol	64-17-5	Y	N	46.07	0.00%	0.00E+00	0.00%
Dimethyl Ether	115-10-5	Y	N	46.07	0.00%	0.00E+00	0.00%
Methyl Acetate	79-20-9	Y	N	74.08	0.00%	0.00E+00	0.00%
Propanol	71-23-8	Y	N	60.10	0.00%	0.00E+00	0.00%
Butanol	71-36-3	Y	N	74.12	0.00%	0.00E+00	0.00%
Acetone	67-64-1	Y	N	58.08	0.00%	0.00E+00	0.00%
MEK	78-93-3	Y	N	72.11	0.00%	0.00E+00	0.00%
Ethane	74-84-0	N	N	30.07	0.00%	0.00E+00	0.00%
Ethylene	74-85-1	Y	N	28.05	0.00%	0.00E+00	0.00%
Propane	74-98-6	Y	N	44.10	0.00%	0.00E+00	0.00%
Propylene	115-07-1	Y	N	42.08	0.00%	0.00E+00	0.00%
Isobutane	75-28-5	Y	N	58.12	0.00%	0.00E+00	0.00%
N-Butane	106-97-8	Y	N	58.12	0.00%	0.00E+00	0.00%
Butylene	26167-67-3	Y	N	56.11	0.00%	0.00E+00	0.00%
Isopentane	78-78-4	Y	N	72.16	0.00%	0.00E+00	0.00%
C4 - C12 Paraffins	N/A	Y	N	114.23	47.85%	4.19E-03	41.62%
C4 - C12 Olefins	N/A	Y	N	112.21	8.39%	7.46E-04	7.41%
C6 - C10 Naphthenes	N/A	Y	N	112.21	11.54%	1.03E-03	10.19%
C6 - C10 Aromatics	N/A	Y	Y	78.11	32.21%	4.12E-03	40.87%
TOTALS					100.00%	1.01E-02	100.00%

Assumed Octane  
Assumed Octene  
Assumed Cyclooctane  
Assumed Benzene

Weight % TOC	100.00%
Weight % VOC	100.00%
Weight % HAP	32.21%

Equipment Type	Fugitive Emissions - SOCM1 Factors			Controlled Emissions				Uncontrolled Emissions
	SOCM1 Emission Factor <sup>1</sup> (kg/hr-source)	% Control With LDAR <sup>2</sup>	Source Count	TOC Emission Rate (kg/hr)	VOC Emission Rate (kg/hr)	Hours of Operation	VOC Emissions (tpy)	VOC Emissions (tpy)
Valves-Gas	0.00587	87.00%	0	0.0000	0.0000	8760	0.00E+00	0.00E+00
Valves-Light Liquids	0.00403	84.00%	0	0.0000	0.0000	8760	0.00E+00	0.00E+00
Valves-Heavy Liquids	0.00023		6	0.0014	0.0014	8760	1.33E-02	1.33E-02
Pump Seals-Light Liquids	0.01980	89.00%	0	0.0000	0.0000	8760	0.00E+00	0.00E+00
Pump Seals-Heavy Liquids	0.00882		0	0.0000	0.0000	8760	0.00E+00	0.00E+00
Compressor Seals-Gas	0.22800		0	0.0000	0.0000	8760	0.00E+00	0.00E+00
Relief Valves-Gas/Vapor	0.10400		0	0.0000	0.0000	8760	0.00E+00	0.00E+00
Connectors	0.00183		6	0.0110	0.0110	8760	1.06E-01	1.06E-01
Open-ended Lines	0.00170		0	0.0000	0.0000	8760	0.00E+00	0.00E+00
Sampling Connections	0.01500		1	0.0150	0.0150	8760	1.45E-01	1.45E-01
Totals				0.03	0.03		0.26	0.26

<sup>1</sup> EPA-453/R-95-017 Protocol for Equipment Leak Emission Estimates (Table 2-1).

<sup>2</sup> EPA-453/R-95-017 Protocol for Equipment Leak Emission Estimates (Table 5-2). Assumes monthly monitoring with leak definition of 10,000 ppmv.

HAP	HAP Emissions - SOCM1 Factors			Controlled Emissions		Uncontrolled Emissions	
	Individual HAP Weight %	VOC Weight %	Hours of Operation	HAP Emissions (lb/hr)	HAP Emissions (ton/yr)	HAP Emissions (lb/hr)	HAP Emissions (ton/yr)
COs	0.00%	100.00%	8760	0.00E+00	0.00E+00	0.00E+00	0.00E+00
Cl2	0.00%	100.00%	8760	0.00E+00	0.00E+00	0.00E+00	0.00E+00
HCl	0.00%	100.00%	8760	0.00E+00	0.00E+00	0.00E+00	0.00E+00
MeOH	0.00%	100.00%	8760	0.00E+00	0.00E+00	0.00E+00	0.00E+00
C6 - C10 Aromatics	32.21%	100.00%	8760	1.94E-02	8.51E-02	1.94E-02	8.51E-02
Total				0.02	0.09	0.02	0.09

Medicine Bow Fuel & Power Industrial Gasification & Liquefaction Plant  
LPG Process Stream

Stream Name: LPG  
Service Type: Light Liquid  
Hours of Operation: 8760  
This piping is included in the LDAR program.

Chemical Name	CAS Number	VOC	HAP	Molecular Weight (lb/lb-mol)	Weight %	Mole Fraction	Mole Percent
CO	830-08-0	N	N	28.01	8.34%	2.98E-03	13.04%
H2	1333-74-0	N	N	2.02	0.00%	0.00E+00	0.00%
CO2	124-38-9	N	N	44.01	0.00%	0.00E+00	0.00%
H2O	7782-18-6	N	N	18.02	0.00%	0.00E+00	0.00%
CH4	74-82-8	N	N	16.04	0.00%	0.00E+00	0.00%
Ar	7440-37-1	N	N	39.95	0.00%	0.00E+00	0.00%
N2	7727-37-9	N	N	28.01	0.00%	0.00E+00	0.00%
H2S	7783-06-4	N	N	34.08	0.00%	0.00E+00	0.00%
COCS	453-58-1	Y	Y	60.07	0.00%	0.00E+00	0.00%
NH3	7664-41-7	N	N	17.03	0.00%	0.00E+00	0.00%
O2	7782-44-7	N	N	32.00	0.00%	0.00E+00	0.00%
SO2	7446-09-5	N	N	64.06	0.00%	0.00E+00	0.00%
Cl2	7782-50-5	N	Y	70.91	0.00%	0.00E+00	0.00%
HCl	7647-01-0	N	Y	36.46	0.00%	0.00E+00	0.00%
MeOH	67-56-1	Y	Y	32.04	0.00%	0.00E+00	0.00%
Ethanol	64-17-5	Y	N	46.07	0.00%	0.00E+00	0.00%
Dimethyl Ether	115-10-8	Y	N	46.07	0.00%	0.00E+00	0.00%
Methyl Acetate	79-20-9	Y	N	74.08	0.00%	0.00E+00	0.00%
Propanol	71-23-8	Y	N	60.10	0.00%	0.00E+00	0.00%
Butanol	71-36-3	Y	N	74.12	0.00%	0.00E+00	0.00%
Acetone	67-64-1	Y	N	58.08	0.00%	0.00E+00	0.00%
MEK	78-93-3	Y	N	72.11	3.60%	5.00E-04	2.19%
Ethane	74-84-0	N	N	30.07	0.00%	0.00E+00	0.00%
Ethylene	74-85-1	Y	N	28.05	21.86%	7.79E-03	34.13%
Propane	74-98-6	Y	N	44.10	0.00%	0.00E+00	0.00%
Propylene	115-07-1	Y	N	42.08	0.00%	0.00E+00	0.00%
Isobutane	75-28-5	Y	N	58.12	37.82%	6.51E-03	28.49%
n-Butane	106-97-8	Y	N	58.12	0.00%	0.00E+00	0.00%
Butylene	25167-67-3	Y	N	56.11	28.38%	5.06E-03	22.15%
Isopentane	78-78-4	Y	N	72.16	0.00%	0.00E+00	0.00%
C4 - C12 Paraffins	N/A	Y	N	114.23	0.00%	0.00E+00	0.00%
C4 - C12 Olefins	N/A	Y	N	112.21	0.00%	0.00E+00	0.00%
C6 - C10 Naphthenes	N/A	Y	N	112.21	0.00%	0.00E+00	0.00%
C6 - C10 Aromatics	N/A	Y	Y	78.11	0.00%	0.00E+00	0.00%
TOTALS					100.00%	2.28E-02	100.00%

Assumed Colene  
Assumed Colene  
Assumed Cyclooctene  
Assumed Benzene

Weight % TOC	91.66%
Weight % VOC	91.66%
Weight % HAP	0.00%

Fugitive Emissions - SOCM Factors				Controlled Emissions				Uncontrolled Emissions	
Equipment Type	SOCMI Emission Factor <sup>1</sup> (kg/hr-source)	% Control With LDAR <sup>2</sup>	Source Count	TOC Emission Rate (kg/hr)	VOC Emission Rate (kg/hr)	Hours of Operation	VOC Emissions (tpy)	VOC Emissions (tpy)	
Valves-Gas	0.00697	87.00%	0	0.0000	0.0000	8760	0.00E+00	0.00E+00	
Valves-Light Liquids	0.00403	84.00%	28	0.0165	0.0165	8760	1.60E-01	9.98E-01	
Valves-Heavy Liquids	0.00023		0	0.0000	0.0000	8760	0.00E+00	0.00E+00	
Pump Seals-Light Liquids	0.01990	69.00%	2	0.0113	0.0113	8760	1.09E-01	3.52E-01	
Pump Seals-Heavy Liquids	0.00852		0	0.0000	0.0000	8760	0.00E+00	0.00E+00	
Compressor Seals-Gas	0.22800		0	0.0000	0.0000	8760	0.00E+00	0.00E+00	
Relief Valves-Gas/Vapor	0.10400		0	0.0000	0.0000	8760	0.00E+00	0.00E+00	
Connectors	0.00183		20	0.0335	0.0335	8760	3.24E-01	3.24E-01	
Open-ended Lines	0.00170		0	0.0000	0.0000	8760	0.00E+00	0.00E+00	
Sampling Connections	0.01500		4	0.0550	0.0550	8760	5.31E-01	5.31E-01	
Totals				0.12	0.12		1.12	2.21	

<sup>1</sup> EPA-453/R-95-017 Protocol for Equipment Leak Emission Estimates (Table 2-1).

<sup>2</sup> EPA-453/R-95-017 Protocol for Equipment Leak Emission Estimates (Table 5-2). Assumes monthly monitoring with leak definition of 10,000 ppmv.

HAP Emissions - SOCM Factors				Controlled Emissions		Uncontrolled Emissions	
HAP	Individual HAP Weight %	VOC Weight %	Hours of Operation	HAP Emissions (lb/hr)	HAP Emissions (ton/yr)	HAP Emissions (lb/hr)	HAP Emissions (ton/yr)
COCS	0.00%	91.66%	8760	0.00E+00	0.00E+00	0.00E+00	0.00E+00
Cl2	0.00%	91.66%	8760	0.00E+00	0.00E+00	0.00E+00	0.00E+00
HCl	0.00%	91.66%	8760	0.00E+00	0.00E+00	0.00E+00	0.00E+00
MeOH	0.00%	91.66%	8760	0.00E+00	0.00E+00	0.00E+00	0.00E+00
CS - C10 Aromatics	0.00%	91.66%	8760	0.00E+00	0.00E+00	0.00E+00	0.00E+00
Total				0.00	0.00	0.00	0.00

Medicine Bow Fuel & Power Industrial Gasification & Liquefaction Plant  
Methanol Gas Process Stream

Stream Name: Methanol Gas  
Service Type: Gas  
Hours of Operation: 8760  
This piping is included in the LDAR program.

Chemical Name	CAS Number	VOC	HAP	Molecular Weight (lb/lb-mol)	Weight %	Mole Fraction	Mole Percent
CO	630-08-0	N	N	28.01	0.02%	6.44E-06	0.02%
H2	1333-74-0	N	N	2.02	0.00%	3.19E-05	0.01%
CO2	124-38-9	N	N	44.01	0.30%	6.92E-05	0.22%
H2O	7732-18-5	N	N	18.02	3.15%	1.75E-03	5.49%
CH4	74-82-8	N	N	16.04	0.03%	1.59E-05	0.05%
Ar	7440-37-1	N	N	39.95	0.08%	1.61E-05	0.05%
N2	7727-37-9	N	N	28.01	0.03%	1.14E-05	0.04%
H2S	7783-06-4	N	N	34.08	0.00%	0.00E+00	0.00%
COS	483-68-1	Y	Y	60.07	0.00%	0.00E+00	0.00%
NH3	7664-41-7	N	N	17.03	0.00%	0.00E+00	0.00%
O2	7782-44-7	N	N	32.00	0.00%	0.00E+00	0.00%
SO2	7446-09-5	N	N	64.06	0.00%	0.00E+00	0.00%
Cl2	7782-50-5	N	Y	70.91	0.00%	0.00E+00	0.00%
HCl	7647-01-0	N	Y	36.46	0.00%	0.00E+00	0.00%
MeOH	67-56-1	Y	Y	32.04	95.19%	3.00E-02	94.01%
Ethanol	64-17-5	Y	N	46.07	0.05%	1.04E-05	0.03%
Dimethyl Ether	115-10-6	Y	N	46.07	0.03%	7.31E-06	0.02%
Methyl Acetate	79-20-9	Y	N	74.08	0.08%	1.10E-05	0.03%
Propanol	71-23-8	Y	N	60.10	0.02%	4.00E-06	0.01%
Butanol	71-36-3	Y	N	74.12	0.02%	2.60E-06	0.01%
Acetone	67-64-1	Y	N	58.08	0.00%	3.31E-07	0.00%
MEK	78-93-3	Y	N	72.11	0.00%	1.33E-07	0.00%
Ethane	74-84-0	N	N	30.07	0.00%	0.00E+00	0.00%
Ethylene	74-85-1	Y	N	28.05	0.00%	0.00E+00	0.00%
Propane	74-98-6	Y	N	44.10	0.00%	0.00E+00	0.00%
Propylene	115-07-1	Y	N	42.08	0.00%	0.00E+00	0.00%
Isobutane	75-28-5	Y	N	58.12	0.00%	0.00E+00	0.00%
N-Butane	108-97-8	Y	N	58.12	0.00%	0.00E+00	0.00%
Butylene	25157-67-3	Y	N	56.11	0.00%	0.00E+00	0.00%
Isopentane	78-78-4	Y	N	72.15	0.00%	0.00E+00	0.00%
C4 - C12 Paraffins	N/A	Y	N	114.23	0.00%	0.00E+00	0.00%
C4 - C12 Olefins	N/A	Y	N	112.21	0.00%	0.00E+00	0.00%
C6 - C10 Naphthenes	N/A	Y	N	112.21	0.00%	0.00E+00	0.00%
C6 - C10 Aromatics	N/A	Y	Y	78.11	0.00%	0.00E+00	0.00%
TOTALS					100.00%	3.19E-02	100.00%

Assumed Octane  
Assumed Octane  
Assumed Cyclooctane  
Assumed Benzene

Weight % TOC	95.42%
Weight % VOC	95.40%
Weight % HAP	95.19%

Equipment Type	Fugitive Emissions - SOCM1 Factors			Controlled Emissions				Uncontrolled Emissions
	SOCM1 Emission Factor <sup>1</sup> (kg/hr-source)	% Control With LDAR <sup>2</sup>	Source Count	TOC Emission Rate (kg/hr)	VOC Emission Rate (kg/hr)	Hours of Operation	VOC Emissions (tpy)	VOC Emissions (tpy)
Valves-Gas	0.00597	87.00%	5	0.0057	0.0037	8760	3.61E-02	2.78E-01
Valves-Light Liquids	0.00403	84.00%	0	0.0000	0.0000	8760	0.00E+00	0.00E+00
Valves-Heavy Liquids	0.00023		0	0.0000	0.0000	8760	0.00E+00	0.00E+00
Pump Seals-Light Liquids	0.01990	69.00%	0	0.0000	0.0000	8760	0.00E+00	0.00E+00
Pump Seals-Heavy Liquids	0.00882		0	0.0000	0.0000	8760	0.00E+00	0.00E+00
Compressor Seals-Gas	0.22800		0	0.0000	0.0000	8760	0.00E+00	0.00E+00
Relief Valves-Gas/Vapor	0.10400		1	0.1003	0.1003	8760	9.68E-01	9.68E-01
Connectors	0.00183		2	0.0035	0.0035	8760	3.41E-02	3.41E-02
Open-ended Lines	0.00170		0	0.0000	0.0000	8760	0.00E+00	0.00E+00
Sampling Connections	0.01600		0	0.0000	0.0000	8760	0.00E+00	0.00E+00
Totals				0.11	0.11		1.04	1.28

<sup>1</sup> EPA-453/R-95-017 Protocol for Equipment Leak Emission Estimates (Table 2-1).  
<sup>2</sup> EPA-453/R-95-017 Protocol for Equipment Leak Emission Estimates (Table 5-2). Assumes monthly monitoring with leak definition of 10,000 ppmv.

HAP	HAP Emissions - SOCM1 Factors			Controlled Emissions		Uncontrolled Emissions	
	Individual HAP Weight %	VOC Weight %	Hours of Operation	HAP Emissions (lb/hr)	HAP Emissions (ton/yr)	HAP Emissions (lb/hr)	HAP Emissions (ton/yr)
COS	0.00%	95.40%	8760	0.00E+00	0.00E+00	0.00E+00	0.00E+00
Cl2	0.00%	95.40%	8760	0.00E+00	0.00E+00	0.00E+00	0.00E+00
HCl	0.00%	95.40%	8760	0.00E+00	0.00E+00	0.00E+00	0.00E+00
MeOH	95.19%	95.40%	8760	2.38E-01	1.04E+00	2.92E-01	1.28E+00
C6 - C10 Aromatics	0.00%	95.40%	8760	0.00E+00	0.00E+00	0.00E+00	0.00E+00
Total				0.24	1.04	0.29	1.28

Medicine Bow Fuel & Power Industrial Gasification & Liquefaction Plant  
Methanol Pure Liquid Process Stream

Stream Name: Methanol Pure Liquid  
Service Type: Light Liquid  
Hours of Operation: 8760  
This piping is included in the LDAR program.

Chemical Name	CAS Number	VOC	HAP	Molecular Weight (lb/lb-mol)	Weight %	Mole Fraction	Mole Percent
CO	630-08-0	N	N	28.01	0.00%	0.00E+00	0.00%
H2	1333-74-0	N	N	2.02	0.00%	0.00E+00	0.00%
CO2	124-38-9	N	N	44.01	0.00%	0.00E+00	0.00%
H2O	7732-18-5	N	N	18.02	0.00%	0.00E+00	0.00%
CH4	74-82-6	N	N	16.04	0.00%	0.00E+00	0.00%
Ar	7440-37-1	N	N	39.95	0.00%	0.00E+00	0.00%
N2	7727-37-9	N	N	28.01	0.00%	0.00E+00	0.00%
H2S	7783-06-4	N	N	34.08	0.00%	0.00E+00	0.00%
COS	483-58-1	Y	Y	60.07	0.00%	0.00E+00	0.00%
NH3	7864-41-7	N	N	17.03	0.00%	0.00E+00	0.00%
O2	7782-44-7	N	N	32.00	0.00%	0.00E+00	0.00%
SO2	7446-09-5	N	N	64.06	0.00%	0.00E+00	0.00%
Cl2	7782-50-5	N	Y	70.91	0.00%	0.00E+00	0.00%
HCl	7847-01-0	N	Y	36.46	0.00%	0.00E+00	0.00%
MeOH	67-56-1	Y	Y	32.04	100.00%	3.12E-02	100.00%
Ethanol	64-17-6	Y	N	46.07	0.00%	0.00E+00	0.00%
Dimethyl Ether	115-10-6	Y	N	46.07	0.00%	0.00E+00	0.00%
Methyl Acetate	79-20-9	Y	N	74.08	0.00%	0.00E+00	0.00%
Propanol	71-23-8	Y	N	60.10	0.00%	0.00E+00	0.00%
Butanol	71-36-3	Y	N	74.12	0.00%	0.00E+00	0.00%
Acetone	67-64-1	Y	N	58.08	0.00%	0.00E+00	0.00%
MEK	78-93-3	Y	N	72.11	0.00%	0.00E+00	0.00%
Ethane	74-84-0	N	N	30.07	0.00%	0.00E+00	0.00%
Ethylene	74-85-1	Y	N	28.05	0.00%	0.00E+00	0.00%
Propane	74-98-6	Y	N	44.10	0.00%	0.00E+00	0.00%
Propylene	115-07-1	Y	N	42.08	0.00%	0.00E+00	0.00%
Isobutane	75-28-5	Y	N	58.12	0.00%	0.00E+00	0.00%
n-Butane	106-97-9	Y	N	58.12	0.00%	0.00E+00	0.00%
Isobutene	25167-67-3	Y	N	56.11	0.00%	0.00E+00	0.00%
Isopentane	78-76-4	Y	N	72.15	0.00%	0.00E+00	0.00%
C4 - C12 Paraffins	N/A	Y	N	114.23	0.00%	0.00E+00	0.00%
C4 - C12 Olefins	N/A	Y	N	112.21	0.00%	0.00E+00	0.00%
C6 - C10 Naphthenes	N/A	Y	N	112.21	0.00%	0.00E+00	0.00%
C6 - C10 Aromatics	N/A	Y	Y	78.11	0.00%	0.00E+00	0.00%
TOTALS					100.00%	3.12E-02	100.00%

Assumed Octane  
Assumed Octene  
Assumed Cyclooctane  
Assumed Benzene

Weight % TOC	100.00%
Weight % VOC	100.00%
Weight % HAP	100.00%

Fugitive Emissions - SOCMF Factors				Controlled Emissions				Uncontrolled Emissions
Equipment Type	SOCMF Emission Factor <sup>1</sup> (kg/hr-source)	% Control With LDAR <sup>2</sup>	Source Count	TOC Emission Rate (kg/hr)	VOC Emission Rate (kg/hr)	Hours of Operation	VOC Emissions (tpy)	VOC Emissions (tpy)
Valves-Gas	0.00597	87.00%	0	0.0000	0.0000	8760	0.00E+00	0.00E+00
Valves-Light Liquids	0.00403	84.00%	15	0.0103	0.0103	8760	9.95E-02	6.22E-01
Valves-Heavy Liquids	0.00023		0	0.0000	0.0000	8760	0.00E+00	0.00E+00
Pump Seals-Light Liquids	0.01980	69.00%	2	0.0123	0.0123	8760	1.19E-01	3.84E-01
Pump Seals-Heavy Liquids	0.00882		0	0.0000	0.0000	8760	0.00E+00	0.00E+00
Compressor Seals-Gas	0.22800		0	0.0000	0.0000	8760	0.00E+00	0.00E+00
Relief Valves-Gas/Vapor	0.10400		0	0.0000	0.0000	8760	0.00E+00	0.00E+00
Connectors	0.00183		8	0.0146	0.0146	8760	1.41E-01	1.41E-01
Open-ended Lines	0.00170		0	0.0000	0.0000	8760	0.00E+00	0.00E+00
Sampling Connections	0.01500		2	0.0300	0.0300	8760	2.90E-01	2.90E-01
Totals				0.07	0.07		0.65	1.44

<sup>1</sup> EPA-453/R-95-017 Protocol for Equipment Leak Emission Estimates (Table 2-1).

<sup>2</sup> EPA-453/R-95-017 Protocol for Equipment Leak Emission Estimates (Table 5-2). Assumes monthly monitoring with leak definition of 10,000 ppmv.

HAP Emissions - SOCMF Factors				Controlled Emissions		Uncontrolled Emissions	
HAP	Individual HAP Weight %	VOC Weight %	Hours of Operation	HAP Emissions (lb/hr)	HAP Emissions (ton/yr)	HAP Emissions (lb/hr)	HAP Emissions (ton/yr)
COS	0.00%	100.00%	8760	0.00E+00	0.00E+00	0.00E+00	0.00E+00
Cl2	0.00%	100.00%	8760	0.00E+00	0.00E+00	0.00E+00	0.00E+00
HCl	0.00%	100.00%	8760	0.00E+00	0.00E+00	0.00E+00	0.00E+00
MeOH	100.00%	100.00%	8760	1.48E-01	6.50E-01	3.28E-01	1.44E+00
C6 - C10 Aromatics	0.00%	100.00%	8760	0.00E+00	0.00E+00	0.00E+00	0.00E+00
Total				0.15	0.65	0.33	1.44

Medicine Bow Fuel & Power Industrial Gasification & Liquefaction Plant  
Methanol Product (MeOH 1) Process Stream

Stream Name: Methanol Product (MeOH 1)  
Service Type: Light Liquid  
Hours of Operation: 8760  
This piping is included in the LDAR program.

Chemical Name	CAS Number	VOC	HAP	Molecular Weight (lb/lb-mol)	Weight %	Mole Fraction	Mole Percent
CO	630-08-0	N	N	28.01	0.02%	6.44E-06	0.02%
H2	1333-74-0	N	N	2.02	0.00%	3.19E-06	0.01%
CO2	124-38-9	N	N	44.01	0.30%	6.92E-05	0.22%
H2O	7732-18-5	N	N	18.02	3.16%	1.76E-03	5.49%
CH4	74-82-8	N	N	16.04	0.03%	1.59E-05	0.05%
Ar	7440-37-1	N	N	39.95	0.06%	1.61E-05	0.05%
N2	7727-37-9	N	N	28.01	0.03%	1.14E-05	0.04%
H2S	7783-06-4	N	N	34.08	0.00%	0.00E+00	0.00%
COS	483-58-1	Y	Y	60.07	0.00%	0.00E+00	0.00%
NH3	7664-41-7	N	N	17.03	0.00%	0.00E+00	0.00%
O2	7782-44-7	N	N	32.00	0.00%	0.00E+00	0.00%
SO2	7446-09-5	N	N	64.05	0.00%	0.00E+00	0.00%
Cl2	7782-50-5	N	Y	70.91	0.00%	0.00E+00	0.00%
HCl	7647-01-0	N	Y	36.46	0.00%	0.00E+00	0.00%
MeOH	67-58-1	Y	Y	32.04	96.19%	3.00E-02	94.01%
Ethanol	64-17-5	Y	N	46.07	0.05%	1.04E-05	0.03%
Dimethyl Ether	115-10-6	Y	N	46.07	0.03%	7.31E-06	0.02%
Methyl Acetate	79-20-9	Y	N	74.08	0.08%	1.10E-05	0.03%
Propanol	71-23-8	Y	N	60.10	0.02%	4.00E-06	0.01%
Butanol	71-36-3	Y	N	74.12	0.02%	2.60E-06	0.01%
Acetone	67-64-1	Y	N	58.08	0.00%	3.31E-07	0.00%
MEK	78-93-3	Y	N	72.11	0.00%	1.33E-07	0.00%
Ethane	74-84-0	N	N	30.07	0.00%	0.00E+00	0.00%
Ethylene	74-85-1	Y	N	28.05	0.00%	0.00E+00	0.00%
Propane	74-98-6	Y	N	44.10	0.00%	0.00E+00	0.00%
Propylene	115-07-1	Y	N	42.08	0.00%	0.00E+00	0.00%
Isobutane	75-28-5	Y	N	58.12	0.00%	0.00E+00	0.00%
n-Butane	106-97-8	Y	N	58.12	0.00%	0.00E+00	0.00%
Butylene	25167-67-3	Y	N	56.11	0.00%	0.00E+00	0.00%
Isopentane	78-78-4	Y	N	72.15	0.00%	0.00E+00	0.00%
C4 - C12 Paraffins	N/A	Y	N	114.23	0.00%	0.00E+00	0.00%
C4 - C12 Olefins	N/A	Y	N	112.21	0.00%	0.00E+00	0.00%
C6 - C10 Naphthenes	N/A	Y	N	112.21	0.00%	0.00E+00	0.00%
C6 - C10 Aromatics	N/A	Y	Y	78.11	0.00%	0.00E+00	0.00%
TOTALS					100.00%	3.19E-02	100.00%

Assumed Octane  
Assumed Octane  
Assumed Cyclooctane  
Assumed Benzene

Weight % TOC	96.42%
Weight % VOC	96.40%
Weight % HAP	96.19%

Equipment Type	Fugitive Emissions - SOCM1 Factors			Controlled Emissions				Uncontrolled Emissions
	SOCM1 Emission Factor <sup>1</sup> (kg/hr-source)	% Control With LDAR <sup>2</sup>	Source Count	TOC Emission Rate (kg/hr)	VOC Emission Rate (kg/hr)	Hours of Operation	VOC Emissions (tpy)	VOC Emissions (tpy)
Valves-Gas	0.00597	87.00%	0	0.0000	0.0000	8760	0.00E+00	0.00E+00
Valves-Light Liquids	0.00403	84.00%	134	0.0833	0.0833	8760	8.04E-01	5.03E+00
Valves-Heavy Liquids	0.00023		0	0.0000	0.0000	8760	0.00E+00	0.00E+00
Pump Seals-Light Liquids	0.01990	69.00%	22	0.1309	0.1308	8760	1.26E+00	4.07E+00
Pump Seals-Heavy Liquids	0.00862		0	0.0000	0.0000	8760	0.00E+00	0.00E+00
Compressor Seals-Gas	0.22800		0	0.0000	0.0000	8760	0.00E+00	0.00E+00
Relief Valves-Gas/Vapor	0.10400		0	0.0000	0.0000	8760	0.00E+00	0.00E+00
Connectors	0.00183		95	0.1694	0.1693	8760	1.63E+00	1.63E+00
Open-ended Lines	0.00170		16	0.0262	0.0262	8760	2.53E-01	2.53E-01
Sampling Connections	0.01500		28	0.4050	0.4049	8760	3.91E+00	3.91E+00
Totals				0.81	0.81		7.86	14.90

<sup>1</sup> EPA-453/R-95-017 Protocol for Equipment Leak Emission Estimates (Table 2-1).

<sup>2</sup> EPA-453/R-95-017 Protocol for Equipment Leak Emission Estimates (Table 5-2). Assumes monthly monitoring with leak definition of 10,000 ppmv.

HAP	HAP Emissions - SOCM1 Factors			Controlled Emissions		Uncontrolled Emissions	
	Individual HAP Weight %	VOC Weight %	Hours of Operation	HAP Emissions (lb/hr)	HAP Emissions (ton/yr)	HAP Emissions (lb/hr)	HAP Emissions (ton/yr)
CO2	0.00%	96.40%	8760	0.00E+00	0.00E+00	0.00E+00	0.00E+00
Cl2	0.00%	96.40%	8760	0.00E+00	0.00E+00	0.00E+00	0.00E+00
HCl	0.00%	96.40%	8760	0.00E+00	0.00E+00	0.00E+00	0.00E+00
MeOH	96.19%	96.40%	8760	1.79E+00	7.85E+00	3.39E+00	1.49E+01
C6 - C10 Aromatics	0.00%	96.40%	8760	0.00E+00	0.00E+00	0.00E+00	0.00E+00
Total				1.79	7.85	3.39	14.86

Medicine Bow Fuel & Power Industrial Gasification & Liquefaction Plant  
Methanol Product (MeOH 2) Process Stream

Stream Name: Methanol Product (MeOH 2)  
Service Type: Light Liquid  
Hours of Operation: 8760  
This piping is included in the LDAR program.

Chemical Name	CAS Number	VOC	HAP	Molecular Weight (lb/lb-mol)	Weight %	Mole Fraction	Mole Percent
CO	630-08-0	N	N	28.01	0.08%	2.89E-05	0.09%
H2	1333-74-0	N	N	2.02	0.02%	1.09E-04	0.34%
CO2	124-38-9	N	N	44.01	0.42%	8.53E-05	0.30%
H2O	7732-18-5	N	N	18.02	3.32%	1.84E-03	5.74%
CH4	74-82-6	N	N	16.04	0.08%	4.81E-05	0.16%
Ar	7440-37-1	N	N	39.95	0.44%	1.09E-04	0.34%
N2	7727-37-9	N	N	28.01	0.18%	8.42E-05	0.20%
H2S	7782-06-4	N	N	34.08	0.00%	0.00E+00	0.00%
COS	463-58-1	Y	Y	60.07	0.00%	0.00E+00	0.00%
NH3	7664-41-7	N	N	17.03	0.00%	0.00E+00	0.00%
O2	7782-44-7	N	N	32.00	0.00%	0.00E+00	0.00%
SO2	7446-09-5	N	N	64.06	0.00%	0.00E+00	0.00%
Cl2	7782-50-5	N	Y	70.91	0.00%	0.00E+00	0.00%
HCl	7647-01-0	N	Y	36.46	0.00%	0.00E+00	0.00%
MeOH	67-56-1	Y	Y	32.04	95.46%	2.98E-02	92.84%
Ethanol	64-17-5	Y	N	46.07	0.00%	0.00E+00	0.00%
Dimethyl Ether	115-10-6	Y	N	46.07	0.00%	0.00E+00	0.00%
Methyl Acetate	79-20-9	Y	N	74.08	0.00%	0.00E+00	0.00%
Propanol	71-23-8	Y	N	60.10	0.00%	0.00E+00	0.00%
Butanol	71-36-3	Y	N	74.12	0.00%	0.00E+00	0.00%
Acetone	67-64-1	Y	N	58.08	0.00%	0.00E+00	0.00%
MEK	78-93-3	Y	N	72.11	0.00%	0.00E+00	0.00%
Ethane	74-84-0	N	N	30.07	0.00%	0.00E+00	0.00%
Ethylene	74-85-1	Y	N	28.05	0.00%	0.00E+00	0.00%
Propane	74-98-6	Y	N	44.10	0.00%	0.00E+00	0.00%
Propylene	115-07-1	Y	N	42.08	0.00%	0.00E+00	0.00%
Isobutane	75-28-5	Y	N	58.12	0.00%	0.00E+00	0.00%
n-Butane	106-97-8	Y	N	58.12	0.00%	0.00E+00	0.00%
Isobutylene	25167-67-3	Y	N	56.11	0.00%	0.00E+00	0.00%
Isopentane	75-78-4	Y	N	72.15	0.00%	0.00E+00	0.00%
C4 - C12 Paraffins	N/A	Y	N	114.23	0.00%	0.00E+00	0.00%
C4 - C12 Olefins	N/A	Y	N	112.21	0.00%	0.00E+00	0.00%
C6 - C10 Naphthenes	N/A	Y	N	112.21	0.00%	0.00E+00	0.00%
C6 - C10 Aromatics	N/A	Y	Y	76.11	0.00%	0.00E+00	0.00%
TOTALS					100.00%	3.21E-02	100.00%

Assumed Octane  
Assumed Octane  
Assumed Cyclooctane  
Assumed Benzene

Weight % TOC	95.54%
Weight % VOC	95.46%
Weight % HAP	95.46%

Fugitive Emissions - SOCMi Factors				Controlled Emissions				Uncontrolled Emissions
Equipment Type	SOCMi Emission Factor <sup>1</sup> (kg/hr-source)	% Control With LDAR <sup>2</sup>	Source Count	TOC Emission Rate (kg/hr)	VOC Emission Rate (kg/hr)	Hours of Operation	VOC Emissions (tpy)	VOC Emissions (tpy)
Valves-Gas	0.00597	87.00%	0	0.0000	0.0000	8760	0.00E+00	0.00E+00
Valves-Light Liquids	0.00403	84.00%	10	0.0082	0.0082	8760	5.94E-02	3.71E-01
Valves-Heavy Liquids	0.00023		0	0.0000	0.0000	8760	0.00E+00	0.00E+00
Pump Seals-Light Liquids	0.01990	69.00%	0	0.0000	0.0000	8760	0.00E+00	0.00E+00
Pump Seals-Heavy Liquids	0.00882		0	0.0000	0.0000	8760	0.00E+00	0.00E+00
Compressor Seals-Gas	0.22800		0	0.0000	0.0000	8760	0.00E+00	0.00E+00
Relief Valves-Gas/Vapor	0.10400		0	0.0000	0.0000	8760	0.00E+00	0.00E+00
Connectors	0.00183		10	0.0175	0.0175	8760	1.69E-01	1.69E-01
Open-ended Lines	0.00170		0	0.0000	0.0000	8760	0.00E+00	0.00E+00
Sampling Connections	0.01500		0	0.0000	0.0000	8760	0.00E+00	0.00E+00
Totals				0.02	0.02		0.23	0.54

<sup>1</sup> EPA-453/R-95-017 Protocol for Equipment Leak Emission Estimates (Table 2-1).

<sup>2</sup> EPA-453/R-95-017 Protocol for Equipment Leak Emission Estimates (Table 5-2). Assumes monthly monitoring with leak definition of 10,000 ppmv.

HAP Emissions - SOCMi Factors				Controlled Emissions		Uncontrolled Emissions	
HAP	Individual HAP Weight %	VOC Weight %	Hours of Operation	HAP Emissions (lb/hr)	HAP Emissions (ton/yr)	HAP Emissions (lb/hr)	HAP Emissions (ton/yr)
CO	0.00%	95.46%	8760	0.00E+00	0.00E+00	0.00E+00	0.00E+00
Cl2	0.00%	95.46%	8760	0.00E+00	0.00E+00	0.00E+00	0.00E+00
HCl	0.00%	95.46%	8760	0.00E+00	0.00E+00	0.00E+00	0.00E+00
MeOH	95.46%	95.46%	8760	5.21E-02	2.28E-01	1.23E-01	5.40E-01
C6 - C10 Aromatics	0.00%	95.46%	8760	0.00E+00	0.00E+00	0.00E+00	0.00E+00
Total				0.05	0.23	0.12	0.54

Medicine Bow Fuel & Power Industrial Gasification & Liquefaction Plant  
Methanol Product (MeOH 3) Process Stream

Stream Name: Methanol Product (MeOH 3)  
Service Type: Light Liquid  
Hours of Operation: 8760  
This piping is included in the LDAR program.

Chemical Name	CAS Number	VOC	HAP	Molecular Weight (lb/lb-mol)	Weight %	Mole Fraction	Mole Percent
CO	630-08-0	N	N	28.01	0.07%	2.57E-05	0.08%
H2	1333-74-0	N	N	2.02	0.02%	1.16E-04	0.36%
CO2	124-98-9	N	N	44.01	0.42%	9.65E-05	0.30%
H2O	7732-18-5	N	N	18.02	3.62%	2.01E-03	5.25%
CH4	74-82-8	N	N	16.04	0.08%	5.15E-05	0.16%
Ar	7440-37-1	N	N	39.95	0.48%	1.18E-04	0.36%
N2	7727-37-9	N	N	28.01	0.18%	6.78E-05	0.21%
H2S	7783-06-4	N	N	34.08	0.00%	0.00E+00	0.00%
COS	463-58-1	Y	Y	60.07	0.00%	0.00E+00	0.00%
NH3	7664-41-7	N	N	17.03	0.00%	0.00E+00	0.00%
O2	7782-44-7	N	N	32.00	0.00%	0.00E+00	0.00%
SO2	7446-09-5	N	N	64.06	0.00%	0.00E+00	0.00%
Cl2	7782-50-5	N	Y	70.91	0.00%	0.00E+00	0.00%
HCl	7647-01-0	N	Y	36.46	0.00%	0.00E+00	0.00%
MeOH	67-56-1	Y	Y	32.04	95.12%	2.97E-02	92.28%
Ethanol	64-17-5	Y	N	46.07	0.00%	0.00E+00	0.00%
Dimethyl Ether	115-10-6	Y	N	48.07	0.00%	0.00E+00	0.00%
Methyl Acetate	79-20-9	Y	N	74.08	0.00%	0.00E+00	0.00%
Propanol	71-23-8	Y	N	60.10	0.00%	0.00E+00	0.00%
Butanol	71-36-3	Y	N	74.12	0.00%	0.00E+00	0.00%
Acetone	67-64-1	Y	N	58.08	0.00%	0.00E+00	0.00%
MEK	78-93-3	Y	N	72.11	0.00%	0.00E+00	0.00%
Ethane	74-84-0	N	N	30.07	0.00%	0.00E+00	0.00%
Ethylene	74-85-1	Y	N	28.05	0.00%	0.00E+00	0.00%
Propane	74-89-6	Y	N	44.10	0.00%	0.00E+00	0.00%
Propylene	115-07-1	Y	N	42.08	0.00%	0.00E+00	0.00%
Isobutane	75-28-5	Y	N	58.12	0.00%	0.00E+00	0.00%
N-Butane	106-97-8	Y	N	58.12	0.00%	0.00E+00	0.00%
Butylene	25167-57-3	Y	N	56.11	0.00%	0.00E+00	0.00%
Isopentane	78-78-4	Y	N	72.15	0.00%	0.00E+00	0.00%
C4 - C12 Paraffins	N/A	Y	N	114.23	0.00%	0.00E+00	0.00%
C4 - C12 Olefins	N/A	Y	N	112.21	0.00%	0.00E+00	0.00%
C6 - C10 Naphthenes	N/A	Y	N	112.21	0.00%	0.00E+00	0.00%
C6 - C10 Aromatics	N/A	Y	Y	78.11	0.00%	0.00E+00	0.00%
TOTALS					100.00%	3.22E-02	100.00%

Assumed Octane  
Assumed Octane  
Assumed Cyclooctane  
Assumed Benzene

Weight % TOC	95.21%
Weight % VOC	95.12%
Weight % HAP	95.12%

Equipment Type	Fugitive Emissions - SOCM Factors			Controlled Emissions			Uncontrolled Emissions	
	SOCM Emission Factor <sup>1</sup> (kg/hr-source)	% Control With LDAR <sup>2</sup>	Source Count	TOC Emission Rate (kg/hr)	VOC Emission Rate (kg/hr)	Hours of Operation	VOC Emissions (tpy)	VOC Emissions (tpy)
Valves-Gas	0.00537	87.00%	0	0.0000	0.0000	8760	0.00E+00	0.00E+00
Valves-Light Liquids	0.00403	84.00%	10	0.0081	0.0061	8760	5.92E-02	3.70E-01
Valves-Heavy Liquids	0.00023		0	0.0000	0.0000	8760	0.00E+00	0.00E+00
Pump Seals-Light Liquids	0.01990	69.00%	0	0.0000	0.0000	8760	0.00E+00	0.00E+00
Pump Seals-Heavy Liquids	0.00882		0	0.0000	0.0000	8760	0.00E+00	0.00E+00
Compressor Seals-Gas	0.22800		0	0.0000	0.0000	8760	0.00E+00	0.00E+00
Relief Valves-Gas/Vapor	0.10400		0	0.0000	0.0000	8760	0.00E+00	0.00E+00
Connectors	0.00183		10	0.0174	0.0174	8760	1.68E-01	1.68E-01
Open-ended Lines	0.00170		0	0.0000	0.0000	8760	0.00E+00	0.00E+00
Sampling Connections	0.01500		0	0.0000	0.0000	8760	0.00E+00	0.00E+00
Totals				0.02	0.02		0.23	0.54

<sup>1</sup> EPA-453/R-95-017 Protocol for Equipment Leak Emission Estimates (Table 2-1).

<sup>2</sup> EPA-453/R-95-017 Protocol for Equipment Leak Emission Estimates (Table 5-2). Assumes monthly monitoring with leak definition of 10,000 ppmv.

HAP	HAP Emissions - SOCM Factors			Controlled Emissions		Uncontrolled Emissions	
	Individual HAP Weight %	VOC Weight %	Hours of Operation	HAP Emissions (lb/hr)	HAP Emissions (ton/yr)	HAP Emissions (lb/hr)	HAP Emissions (ton/yr)
COS	0.00%	95.12%	8760	0.00E+00	0.00E+00	0.00E+00	0.00E+00
Cl2	0.00%	95.12%	8760	0.00E+00	0.00E+00	0.00E+00	0.00E+00
HCl	0.00%	95.12%	8760	0.00E+00	0.00E+00	0.00E+00	0.00E+00
MeOH	95.12%	95.12%	8760	5.19E-02	2.27E-01	1.23E-01	5.38E-01
C6 - C10 Aromatics	0.00%	95.12%	8760	0.00E+00	0.00E+00	0.00E+00	0.00E+00
Total				0.05	0.23	0.12	0.54



Medicine Bow Fire & Power Industrial Gasification & Liquefaction Plant  
Methanol Product (MeOH 5) Process Stream

Stream Name: Methanol Product (MeOH 5)  
Service Type: Gas  
Hours of Operation: 8760  
This piping is included in the LDAR program.

Chemical Name	CAS Number	VOC	HAP	Molecular Weight (lb/lb-mol)	Weight %	Mole Fraction	Mole Percent
CO	630-08-0	N	N	28.01	15.02%	5.36E-03	7.09%
H2	1333-74-0	N	N	2.02	9.73%	4.83E-02	63.83%
CO2	124-38-9	N	N	44.01	3.93%	8.82E-04	1.18%
H2O	7732-18-5	N	N	18.02	0.08%	3.03E-05	0.04%
CH4	74-82-8	N	N	16.04	2.78%	1.73E-03	2.28%
Ar	7440-37-1	N	N	39.95	47.22%	1.18E-02	15.63%
N2	7727-37-9	N	N	28.01	19.56%	8.99E-03	9.24%
H2S	7783-06-4	N	N	34.08	0.00%	0.00E+00	0.00%
COS	463-58-1	Y	Y	60.07	0.00%	0.00E+00	0.00%
NH3	7664-41-7	N	N	17.03	0.00%	0.00E+00	0.00%
O2	7782-44-7	N	N	32.00	0.00%	0.00E+00	0.00%
SO2	7446-09-5	N	N	64.06	0.00%	0.00E+00	0.00%
Cl2	7782-50-5	N	Y	70.91	0.00%	0.00E+00	0.00%
HCl	7647-01-0	N	Y	36.46	0.00%	0.00E+00	0.00%
MeOH	67-56-1	Y	Y	32.04	1.70%	5.29E-04	0.70%
Ethanol	64-17-5	Y	N	46.07	0.00%	0.00E+00	0.00%
Dimethyl Ether	115-10-6	Y	N	46.07	0.00%	0.00E+00	0.00%
Methyl Acetate	79-20-9	Y	N	74.08	0.00%	0.00E+00	0.00%
Propanol	71-23-3	Y	N	60.10	0.00%	0.00E+00	0.00%
Butanol	71-36-3	Y	N	74.12	0.00%	0.00E+00	0.00%
Acetone	67-64-1	Y	N	58.08	0.00%	0.00E+00	0.00%
MEK	78-93-3	Y	N	72.11	0.00%	0.00E+00	0.00%
Ethane	74-84-0	N	N	30.07	0.00%	0.00E+00	0.00%
Ethylene	74-85-1	Y	N	28.05	0.00%	0.00E+00	0.00%
Propane	74-98-6	Y	N	44.10	0.00%	0.00E+00	0.00%
Propylene	115-07-1	Y	N	42.08	0.00%	0.00E+00	0.00%
Isobutane	75-28-5	Y	N	58.12	0.00%	0.00E+00	0.00%
n-Butane	106-97-8	Y	N	58.12	0.00%	0.00E+00	0.00%
Butylene	25167-67-3	Y	N	66.11	0.00%	0.00E+00	0.00%
Isopentane	78-78-4	Y	N	72.15	0.00%	0.00E+00	0.00%
C4 - C12 Paraffins	N/A	Y	N	114.23	0.00%	0.00E+00	0.00%
C4 - C12 Olefins	N/A	Y	N	112.21	0.00%	0.00E+00	0.00%
C8 - C10 Naphthenes	N/A	Y	N	112.21	0.00%	0.00E+00	0.00%
C8 - C10 Aromatics	N/A	Y	Y	78.11	0.00%	0.00E+00	0.00%
TOTALS					100.00%	7.56E-02	100.00%

Weight % TOC	4.47%
Weight % VOC	1.70%
Weight % HAP	1.70%

Fugitive Emissions - SOCM1 Factors				Controlled Emissions				Uncontrolled Emissions	
Equipment Type	SOCM1 Emission Factor <sup>1</sup> (kg/hr-source)	% Control With LDAR <sup>2</sup>	Source Count	TOC Emission Rate (kg/hr)	VOC Emission Rate (kg/hr)	Hours of Operation	VOC Emissions (tpy)	VOC Emissions (tpy)	
Valves-Gas	0.00597	87.00%	125	0.0043	0.0016	8760	1.59E-02	1.22E-01	
Valves-Light Liquids	0.00403	84.00%	0	0.0000	0.0000	8760	0.00E+00	0.00E+00	
Valves-Heavy Liquids	0.00023		0	0.0000	0.0000	8760	0.00E+00	0.00E+00	
Pump Seals-Light Liquids	0.01980	69.00%	0	0.0000	0.0000	8760	0.00E+00	0.00E+00	
Pump Seals-Heavy Liquids	0.00862		0	0.0000	0.0000	8760	0.00E+00	0.00E+00	
Compressor Seals-Gas	0.22800		0	0.0000	0.0000	8760	0.00E+00	0.00E+00	
Relief Valves-Gas/Vapor	0.10400		16	0.0745	0.0282	8760	2.72E-01	2.72E-01	
Connectors	0.00183		136	0.0111	0.0042	8760	4.08E-02	4.08E-02	
Open-ended Lines	0.00170		0	0.0000	0.0000	8760	0.00E+00	0.00E+00	
Sampling Connections	0.01500		27	0.0181	0.0069	8760	6.63E-02	6.63E-02	
Totals				0.11	0.04		0.40	6.50	

<sup>1</sup> EPA-453/R-95-017 Protocol for Equipment Leak Emission Estimates (Table 2-1).

<sup>2</sup> EPA-453/R-95-017 Protocol for Equipment Leak Emission Estimates (Table 5-2). Assumes monthly monitoring with leak definition of 10,000 ppmv.

HAP Emissions - SOCM1 Factors				Controlled Emissions		Uncontrolled Emissions	
HAP	Individual HAP Weight %	VOC Weight %	Hours of Operation	HAP Emissions (lb/hr)	HAP Emissions (ton/yr)	HAP Emissions (lb/hr)	HAP Emissions (ton/yr)
CO	0.00%	1.70%	8760	0.00E+00	0.00E+00	0.00E+00	0.00E+00
Cl2	0.00%	1.70%	8760	0.00E+00	0.00E+00	0.00E+00	0.00E+00
HCl	0.00%	1.70%	8760	0.00E+00	0.00E+00	0.00E+00	0.00E+00
MeOH	1.70%	1.70%	8760	9.03E-02	3.95E-01	1.15E-01	5.02E-01
CS - C10 Aromatics	0.00%	1.70%	8760	0.00E+00	0.00E+00	0.00E+00	0.00E+00
Total				0.09	0.40	0.11	6.50

Medicine Bow Fuel & Power Industrial Gasification & Liquefaction Plant  
Mixed Fuel Gas Process Stream

Stream Name: Mixed Fuel Gas  
Service Type: Gas  
Hours of Operation: 8760  
This piping is included in the LDAR program.

Chemical Name	CAS Number	VOC	HAP	Molecular Weight (lb/lb-mol)	Weight %	Mole Fraction	Mole Percent
CO	630-08-0	N	N	28.01	1.88%	6.70E-04	1.36%
H2	1333-74-0	N	N	2.02	2.08%	1.02E-02	20.76%
CO2	124-38-9	N	N	44.01	3.98%	7.88E-04	1.55%
H2O	7732-18-5	N	N	18.02	0.01%	7.40E-06	0.02%
CH4	74-82-8	N	N	16.04	39.92%	2.48E-02	50.67%
Ar	7440-37-1	N	N	39.95	15.43%	3.88E-03	7.87%
N2	7727-37-9	N	N	28.01	7.59%	2.71E-03	5.82%
H2S	7783-06-4	N	N	34.08	0.00%	0.00E+00	0.00%
COS	463-58-1	Y	Y	60.07	0.00%	0.00E+00	0.00%
NH3	7664-41-7	N	N	17.03	0.00%	0.00E+00	0.00%
O2	7782-44-7	N	N	32.00	0.00%	0.00E+00	0.00%
SO2	7446-09-5	N	N	64.06	0.00%	0.00E+00	0.00%
Cl2	7782-50-5	N	Y	70.91	0.00%	0.00E+00	0.00%
HCl	7647-01-0	N	Y	36.46	0.00%	0.00E+00	0.00%
MeOH	67-56-1	Y	Y	32.04	0.99%	3.09E-04	0.83%
Ethanol	64-17-5	Y	N	46.07	0.00%	0.00E+00	0.00%
Dimethyl Ether	115-10-6	Y	N	46.07	0.00%	0.00E+00	0.00%
Methyl Acetate	79-20-9	Y	N	74.08	0.00%	0.00E+00	0.00%
Propanol	71-23-8	Y	N	60.10	0.00%	0.00E+00	0.00%
Butanol	71-36-3	Y	N	74.12	0.00%	0.00E+00	0.00%
Acetone	67-64-1	Y	N	58.08	0.00%	0.00E+00	0.00%
MEK	78-93-3	Y	N	72.11	0.00%	0.00E+00	0.00%
Ethane	74-84-0	N	N	30.07	2.02%	6.73E-04	1.37%
Ethylene	74-85-1	Y	N	28.05	0.20%	6.96E-05	0.14%
Propane	74-98-6	Y	N	44.10	7.00%	1.59E-03	3.23%
Propylene	115-07-1	Y	N	42.08	0.36%	8.56E-05	0.17%
Isobutane	75-28-5	Y	N	58.12	16.30%	2.80E-03	5.71%
N-Butane	106-97-8	Y	N	58.12	0.00%	0.00E+00	0.00%
Butylene	25187-67-9	Y	N	56.11	2.32%	4.14E-04	0.84%
Isopentane	78-78-4	Y	N	72.15	0.47%	8.53E-05	0.13%
C4 - C12 Paraffins	N/A	Y	N	114.23	0.08%	8.50E-08	0.01%
C4 - C12 Olefins	N/A	Y	N	112.21	0.00%	0.00E+00	0.00%
C6 - C10 Naphthenes	N/A	Y	N	112.21	0.00%	0.00E+00	0.00%
C6 - C10 Aromatics	N/A	Y	Y	78.11	0.00%	0.00E+00	0.00%
TOTALS					100.00%	4.91E-02	100.00%

Assumed Octane  
Assumed Octane  
Assumed Cyclooctane  
Assumed Benzene

Weight % TOC	69.65%
Weight % VOC	27.71%
Weight % HAP	0.99%

Equipment Type	Fugitive Emissions - SOCM1 Factors			Controlled Emissions				Uncontrolled Emissions	
	SOCM1 Emission Factor <sup>1</sup> (kg/hr-source)	% Control With LDAR <sup>2</sup>	Source Count	TOC Emission Rate (kg/hr)	VOC Emission Rate (kg/hr)	Hours of Operation	VOC Emissions (tpy)	VOC Emissions (tpy)	
Valves-Gas	0.00597	87.00%	90	0.0487	0.0194	8760	1.87E-01	1.44E+00	
Valves-Light Liquids	0.00403	84.00%	0	0.0000	0.0000	8760	0.00E+00	0.00E+00	
Valves-Heavy Liquids	0.00023		0	0.0000	0.0000	8760	0.00E+00	0.00E+00	
Pump Seals-Light Liquids	0.01990	69.00%	0	0.0000	0.0000	8760	0.00E+00	0.00E+00	
Pump Seals-Heavy Liquids	0.00862		0	0.0000	0.0000	8760	0.00E+00	0.00E+00	
Compressor Seals-Gas	0.22800		0	0.0000	0.0000	8760	0.00E+00	0.00E+00	
Relief Valves-Gas/Vapor	0.10400		1	0.0724	0.0288	8760	2.78E-01	2.78E-01	
Connectors	0.00183		11	0.0140	0.0056	8760	5.39E-02	5.39E-02	
Open-ended Lines	0.00170		0	0.0000	0.0000	8760	0.00E+00	0.00E+00	
Sampling Connections	0.01500		0	0.0000	0.0000	8760	0.00E+00	0.00E+00	
Totals				0.14	0.05		0.52	1.77	

<sup>1</sup> EPA-453/R-95-017 Protocol for Equipment Leak Emission Estimates (Table 2-1).

<sup>2</sup> EPA-453/R-95-017 Protocol for Equipment Leak Emission Estimates (Table 5-2). Assumes monthly monitoring with leak definition of 10,000 ppmv.

HAP	HAP Emissions - SOCM1 Factors			Controlled Emissions		Uncontrolled Emissions	
	Individual HAP Weight %	VOC Weight %	Hours of Operation	HAP Emissions (lb/hr)	HAP Emissions (ton/yr)	HAP Emissions (lb/hr)	HAP Emissions (ton/yr)
CO2	0.00%	27.71%	8760	0.00E+00	0.00E+00	0.00E+00	0.00E+00
Cl2	0.00%	27.71%	8760	0.00E+00	0.00E+00	0.00E+00	0.00E+00
HCl	0.00%	27.71%	8760	0.00E+00	0.00E+00	0.00E+00	0.00E+00
MeOH	0.99%	27.71%	8760	4.23E-03	1.85E-02	1.44E-02	6.32E-02
C6 - C10 Aromatics	0.00%	27.71%	8760	0.00E+00	0.00E+00	0.00E+00	0.00E+00
Total				0.00	0.02	0.01	0.06

Medicine Bow Fuel & Power Industrial Gasification & Liquefaction Plant  
 MTG Fuel Gas Process Stream

Stream Name: MTG Fuel Gas  
 Service Type: Gas  
 Hours of Operation: 8780  
 This piping is included in the LDAR program.

Chemical Name	CAS Number	VOC	HAP	Molecular Weight (lb/lb-mol)	Weight %	Mole Fraction	Mole Percent
CO	630-08-0	N	N	28.01	34.27%	1.22E-02	34.25%
H2	1333-74-0	N	N	2.02	0.01%	6.11E-05	0.17%
CO2	124-38-9	N	N	44.01	0.00%	0.00E+00	0.00%
H2O	7732-18-5	N	N	18.02	0.39%	2.17E-04	0.51%
CH4	74-82-8	N	N	16.04	22.67%	1.41E-02	39.58%
Ar	7440-37-1	N	N	39.95	0.00%	0.00E+00	0.00%
N2	7727-37-9	N	N	28.01	0.00%	0.00E+00	0.00%
H2S	7783-06-4	N	N	34.08	0.00%	0.00E+00	0.00%
COS	463-58-1	Y	Y	60.07	0.00%	0.00E+00	0.00%
NH3	7664-41-7	N	N	17.03	0.00%	0.00E+00	0.00%
O2	7782-44-7	N	N	32.00	0.00%	0.00E+00	0.00%
SO2	7446-09-5	N	N	64.06	0.00%	0.00E+00	0.00%
Cl2	7782-50-5	N	Y	70.91	0.00%	0.00E+00	0.00%
HCl	7647-01-0	N	Y	36.46	0.00%	0.00E+00	0.00%
MeOH	67-56-1	Y	Y	32.04	0.00%	0.00E+00	0.00%
Ethanol	64-17-5	Y	N	46.07	0.00%	0.00E+00	0.00%
Dimethyl Ether	115-10-6	Y	N	46.07	0.00%	0.00E+00	0.00%
Methyl Acetate	79-20-9	Y	N	74.08	0.00%	0.00E+00	0.00%
Propanol	71-23-8	Y	N	60.10	0.00%	0.00E+00	0.00%
Butanol	71-36-3	Y	N	74.12	0.00%	0.00E+00	0.00%
Acetone	67-64-1	Y	N	58.08	0.00%	0.00E+00	0.00%
MEK	78-93-3	Y	N	72.11	0.00%	0.00E+00	0.00%
Ethane	74-84-0	N	N	30.07	8.92%	2.97E-03	8.31%
Ethylene	74-86-1	Y	N	28.05	5.69%	2.03E-03	5.68%
Propane	74-98-6	Y	N	44.10	6.95%	1.58E-03	4.41%
Propylene	115-07-1	Y	N	42.08	0.30%	7.24E-05	0.20%
Isobutane	75-28-5	Y	N	58.12	2.52%	4.34E-04	1.21%
n-Butane	106-97-8	Y	N	58.12	0.43%	7.48E-05	0.21%
Isobutylene	25167-87-3	Y	N	56.11	0.78%	1.38E-04	0.38%
Isopentane	76-78-4	Y	N	72.15	5.20%	7.21E-04	2.02%
C4 - C12 Paraffins	N/A	Y	N	114.23	7.48%	6.64E-04	1.83%
C4 - C12 Olefins	N/A	Y	N	112.21	2.69%	2.39E-04	0.67%
C6 - C10 Naphthenes	N/A	Y	N	112.21	1.31%	1.17E-04	0.33%
C6 - C10 Aromatics	N/A	Y	Y	78.11	0.38%	4.91E-05	0.14%
TOTALS					100.00%	3.57E-02	100.00%

Weight % TOC	65.33%
Weight % VOC	33.74%
Weight % HAP	0.38%

Fugitive Emissions - SOCMF Factors				Controlled Emissions				Uncontrolled Emissions
Equipment Type	SOCMF Emission Factor <sup>1</sup> (kg/hr-acre)	% Control With LDAR <sup>2</sup>	Source Count	TOC Emission Rate (kg/hr)	VOC Emission Rate (kg/hr)	Hours of Operation	VOC Emissions (tpy)	VOC Emissions (tpy)
Valves-Gas	0.00597	87.00%	60	0.0304	0.0157	8760	1.52E-01	1.17E+00
Valves-Light Liquids	0.00403	84.00%	0	0.0000	0.0000	8760	0.00E+00	0.00E+00
Valves-Heavy Liquids	0.00023		0	0.0000	0.0000	8760	0.00E+00	0.00E+00
Pump Seals-Light Liquids	0.01890	69.00%	0	0.0000	0.0000	8760	0.00E+00	0.00E+00
Pump Seals-Heavy Liquids	0.00862		0	0.0000	0.0000	8760	0.00E+00	0.00E+00
Compressor Seals-Gas	0.22800		4	0.8958	0.3077	8760	2.97E+00	2.97E+00
Relief Valves-Gas/Vapor	0.10400		2	0.1358	0.0702	8760	6.77E-01	6.77E-01
Connectors	0.00183		88	0.1052	0.0543	8760	5.24E-01	5.24E-01
Open-ended Lines	0.00170		0	0.0000	0.0000	8760	0.00E+00	0.00E+00
Sampling Connections	0.01500		2	0.0196	0.0101	8760	9.77E-02	9.77E-02
Totals				0.89	0.46		4.42	5.44

<sup>1</sup> EPA-453/R-95-017 Protocol for Equipment Leak Emission Estimates (Table 2-1).  
<sup>2</sup> EPA-453/R-95-017 Protocol for Equipment Leak Emission Estimates (Table 5-2). Assumes monthly monitoring with leak definition of 10,000 ppmv.

HAP Emissions - SOCMF Factors				Controlled Emissions		Uncontrolled Emissions	
HAP	Individual HAP Weight %	VOC Weight %	Hours of Operation	HAP Emissions (lb/hr)	HAP Emissions (ton/yr)	HAP Emissions (lb/hr)	HAP Emissions (ton/yr)
COS	0.00%	33.74%	8760	0.00E+00	0.00E+00	0.00E+00	0.00E+00
Cl2	0.00%	33.74%	8760	0.00E+00	0.00E+00	0.00E+00	0.00E+00
HCl	0.00%	33.74%	8760	0.00E+00	0.00E+00	0.00E+00	0.00E+00
MeOH	0.00%	33.74%	8760	0.00E+00	0.00E+00	0.00E+00	0.00E+00
C6 - C10 Aromatics	0.38%	33.74%	8760	1.15E-02	5.03E-02	1.41E-02	6.16E-02
Total				0.01	0.05	0.01	0.06

Medicine Bow Fuel & Power Industrial Gasification & Liquefaction Plant  
Propylene Process Stream

Stream Name: Propylene  
Service Type: Gas  
Hours of Operation: 8760  
This piping is included in the LDAR program.

Chemical Name	CAS Number	VOC	HAP	Molecular Weight (lb/lb-mol)	Weight %	Mole Fraction	Mole Percent
CO	630-08-0	N	N	28.01	0.00%	0.00E+00	0.00%
H2	1333-74-0	N	N	2.02	0.00%	0.00E+00	0.00%
CO2	124-38-9	N	N	44.01	0.00%	0.00E+00	0.00%
H2O	7732-18-5	N	N	18.02	0.00%	0.00E+00	0.00%
CH4	74-82-8	N	N	16.04	0.00%	0.00E+00	0.00%
Ar	7440-37-1	N	N	39.95	0.00%	0.00E+00	0.00%
N2	7727-37-9	N	N	28.01	0.00%	0.00E+00	0.00%
H2S	7783-06-4	N	N	34.08	0.00%	0.00E+00	0.00%
COS	463-58-1	Y	Y	60.07	0.00%	0.00E+00	0.00%
NH3	7664-41-7	N	N	17.03	0.00%	0.00E+00	0.00%
O2	7782-44-7	N	N	32.00	0.00%	0.00E+00	0.00%
SO2	7448-09-5	N	N	64.06	0.00%	0.00E+00	0.00%
Cl2	7782-50-5	N	Y	70.91	0.00%	0.00E+00	0.00%
HCl	7647-01-0	N	Y	36.46	0.00%	0.00E+00	0.00%
MeOH	67-56-1	Y	Y	32.04	0.00%	0.00E+00	0.00%
Ethanol	64-17-5	Y	N	46.07	0.00%	0.00E+00	0.00%
Dimethyl Ether	115-10-6	Y	N	46.07	0.00%	0.00E+00	0.00%
Methyl Acetate	79-20-9	Y	N	74.08	0.00%	0.00E+00	0.00%
Propanol	71-23-6	Y	N	60.10	0.00%	0.00E+00	0.00%
Butanol	71-36-3	Y	N	74.12	0.00%	0.00E+00	0.00%
Acetone	67-64-1	Y	N	58.08	0.00%	0.00E+00	0.00%
MEK	78-93-3	Y	N	72.11	0.00%	0.00E+00	0.00%
Ethane	74-84-0	N	N	30.07	0.00%	0.00E+00	0.00%
Ethylene	74-85-1	Y	N	28.05	0.00%	0.00E+00	0.00%
Propane	74-98-6	Y	N	44.10	0.00%	0.00E+00	0.00%
Propylene	115-07-1	Y	N	42.08	100.00%	2.38E-02	100.00%
Isobutane	75-28-5	Y	N	58.12	0.00%	0.00E+00	0.00%
N-Butane	106-97-8	Y	N	58.12	0.00%	0.00E+00	0.00%
Butylene	25167-87-3	Y	N	56.11	0.00%	0.00E+00	0.00%
Isopentane	78-78-4	Y	N	72.15	0.00%	0.00E+00	0.00%
C4 - C12 Paraffins	N/A	Y	N	114.23	0.00%	0.00E+00	0.00%
C4 - C12 Olefins	N/A	Y	N	112.21	0.00%	0.00E+00	0.00%
C6 - C10 Naphthenes	N/A	Y	N	112.21	0.00%	0.00E+00	0.00%
C6 - C10 Aromatics	N/A	Y	Y	78.11	0.00%	0.00E+00	0.00%
TOTALS					100.00%	2.38E-02	100.00%

Assumed Octane  
Assumed Octane  
Assumed Cyclooctane  
Assumed Benzene

Weight % TOC	100.00%
Weight % VOC	100.00%
Weight % HAP	0.00%

Fugitive Emissions - SOCMII Factors				Controlled Emissions				Uncontrolled Emissions
Equipment Type	SOCMII Emission Factor <sup>1</sup> (kg/hr-source)	% Control With LDAR <sup>2</sup>	Source Count	TOC Emission Rate (kg/hr)	VOC Emission Rate (kg/hr)	Hours of Operation	VOC Emissions (tpy)	VOC Emissions (tpy)
Valves-Gas	0.00597	87.00%	40	0.0310	0.0310	8760	3.00E-01	2.31E+00
Valves-Light Liquids	0.00403		0	0.0000	0.0000	8760	0.00E+00	0.00E+00
Valves-Heavy Liquids	0.00023		0	0.0000	0.0000	8760	0.00E+00	0.00E+00
Pump Seals-Light Liquids	0.01980	69.00%	0	0.0000	0.0000	8760	0.00E+00	0.00E+00
Pump Seals-Heavy Liquids	0.00862		0	0.0000	0.0000	8760	0.00E+00	0.00E+00
Compressor Seals-Gas	0.22800		8	1.8240	1.8240	8760	1.76E+01	1.76E+01
Relief Valves-Gas/Vapor	0.10400		4	0.4160	0.4160	8760	4.02E+00	4.02E+00
Connectors	0.00183		8	0.0146	0.0146	8760	1.41E-01	1.41E-01
Open-ended Lines	0.00170		0	0.0000	0.0000	8760	0.00E+00	0.00E+00
Sampling Connections	0.01500		2	0.0300	0.0300	8760	2.90E-01	2.90E-01
Totals				2.32	2.32		22.35	24.36

<sup>1</sup> EPA-453/R-95-017 Protocol for Equipment Leak Emission Estimates (Table 2-1).  
<sup>2</sup> EPA-453/R-95-017 Protocol for Equipment Leak Emission Estimates (Table 5-2). Assumes monthly monitoring with leak definition of 10,000 ppmv.

HAP Emissions - SOCMII Factors				Controlled Emissions		Uncontrolled Emissions	
HAP	Individual HAP Weight %	VOC Weight %	Hours of Operation	HAP Emissions (lb/hr)	HAP Emissions (ton/yr)	HAP Emissions (lb/hr)	HAP Emissions (ton/yr)
COS	0.00%	100.00%	8760	0.00E+00	0.00E+00	0.00E+00	0.00E+00
Cl2	0.00%	100.00%	8760	0.00E+00	0.00E+00	0.00E+00	0.00E+00
HCl	0.00%	100.00%	8760	0.00E+00	0.00E+00	0.00E+00	0.00E+00
MeOH	0.00%	100.00%	8760	0.00E+00	0.00E+00	0.00E+00	0.00E+00
C6 - C10 Aromatics	0.00%	100.00%	8760	0.00E+00	0.00E+00	0.00E+00	0.00E+00
Total				0.00	0.00	0.00	0.00

### TANKS 4.0.9d Emissions Report Detail Format Tank Identification and Physical Characteristics

**Identification**

User Identification: Med Bow F&P Gasoline Tank  
 City: Medicine Bow  
 State: Wyoming  
 Company: Medicine Bow Fuel & Power LLC  
 Type of Tank: Internal Floating Roof Tank  
 Description: Finished gasoline product tank; total 8 identical tanks.

**Tank Dimensions**

Diameter (ft): 150.00  
 Volume (gallons): 6,341,984.00  
 Turnovers: 5.72  
 Self Supp. Roof? (y/n): N  
 No. of Columns: 9.00  
 Eff. Col. Diam. (ft): 1.00

**Paint Characteristics**

Internal Shell Condition: Light Rust  
 Shell Color/Shade: White/White  
 Shell Condition: Good  
 Roof Color/Shade: White/White  
 Roof Condition: Good

**Rim-Seal System**

Primary Seal: Vapor-mounted  
 Secondary Seal: None

**Deck Characteristics**

Deck Fitting Category: Typical  
 Deck Type: Bolted  
 Construction: Panel  
 Deck Seam: Panel: 5 x 7.5 Ft  
 Deck Seam Len. (ft): 5,831.58

**Deck Fitting/Status**

**Quantity**

Access Hatch (24-in. Diam./Unbolted Cover, Ungasketed	1
Automatic Gauge Float Well/Unbolted Cover, Ungasketed	1
Column Well (24-in. Diam./Built-Up Col.-Sliding Cover, Ungask.	9
Ladder Well (36-in. Diam./Sliding Cover, Ungasketed	1
Roof Leg or Hanger Well/Adjustable	58
Sample Pipe or Well (24-in. Diam./Slit Fabric Seal 10% Open	1
Stub Drain (1-in. Diameter)/Slit Fabric Seal 10% Open	180



## TANKS 4.0.9d Emissions Report - Detail Format Liquid Contents of Storage Tank

**Med Bow F&P Gasoline Tank - Internal Floating Roof Tank  
Medicine Bow, Wyoming**

Mixture/Component	Month	Daily Liquid Surf. Temperature (deg F)			Liquid Bulk Temp (deg F)	Vapor Pressure (psia)			Vapor Mol Weight	Liquid Mass Fract.	Vapor Mass Fract.	Mol. Weight	Basis for Vapor Pressure Calculations
		Avg.	Min.	Max.		Avg.	Min.	Max.					
Gasoline (RVP 15.0)	Jan	38.11	33.24	42.99	45.62	5.3659	N/A	N/A	60.0000			92.00	Option 4: RVP=15, ASTM Slope=3
1,2,4-Trimethylbenzene						0.0081	N/A	N/A	120.1900	0.0250	0.0001	120.19	Option 2: A=7.04383, B=1573.267, C=208.56
Benzene						0.6159	N/A	N/A	78.1100	0.0180	0.0032	78.11	Option 2: A=6.905, B=1211.033, C=220.79
Cyclohexane						0.6486	N/A	N/A	84.1600	0.0024	0.0004	84.16	Option 2: A=6.841, B=1201.53, C=222.65
Ethylbenzene						0.0485	N/A	N/A	106.1700	0.0140	0.0002	106.17	Option 2: A=6.975, B=1424.255, C=213.21
Hexane (-n)						1.0503	N/A	N/A	86.1700	0.0100	0.0030	86.17	Option 2: A=6.876, B=1171.17, C=224.41
Isocane							N/A	N/A	114.2200	0.0400	0.0000	114.22	
Isopropyl benzene						0.0202	N/A	N/A	120.2000	0.0050	0.0000	120.20	Option 2: A=6.93666, B=1460.793, C=207.78
Toluene						0.1609	N/A	N/A	92.1300	0.0700	0.0032	92.13	Option 2: A=6.954, B=1344.8, C=219.48
Unidentified Components						6.9375	N/A	N/A	59.7961	0.7458	0.9891	89.36	
Xylene (-m)						0.0401	N/A	N/A	106.1700	0.0700	0.0008	106.17	Option 2: A=7.009, B=1462.266, C=215.11
Gasoline (RVP 13.5)	Feb	39.75	34.55	44.94	45.82	4.8987	N/A	N/A	62.0000			92.00	Option 4: RVP=13.5, ASTM Slope=3
1,2,4-Trimethylbenzene						0.0087	N/A	N/A	120.1900	0.0250	0.0001	120.19	Option 2: A=7.04383, B=1573.267, C=208.56
Benzene						0.6475	N/A	N/A	78.1100	0.0180	0.0035	78.11	Option 2: A=6.905, B=1211.033, C=220.79
Cyclohexane						0.6811	N/A	N/A	84.1600	0.0024	0.0005	84.16	Option 2: A=6.841, B=1201.53, C=222.65
Ethylbenzene						0.0517	N/A	N/A	106.1700	0.0140	0.0002	106.17	Option 2: A=6.975, B=1424.255, C=213.21
Hexane (-n)						1.1008	N/A	N/A	86.1700	0.0100	0.0033	86.17	Option 2: A=6.876, B=1171.17, C=224.41
Isocane							N/A	N/A	114.2200	0.0400	0.0000	114.22	
Isopropyl benzene						0.0216	N/A	N/A	120.2000	0.0050	0.0000	120.20	Option 2: A=6.93666, B=1460.793, C=207.78
Toluene						0.1702	N/A	N/A	92.1300	0.0700	0.0036	92.13	Option 2: A=6.954, B=1344.8, C=219.48
Unidentified Components						6.3261	N/A	N/A	61.7817	0.7458	0.9878	89.36	
Xylene (-m)						0.0428	N/A	N/A	106.1700	0.0700	0.0009	106.17	Option 2: A=7.009, B=1462.266, C=215.11
Gasoline (RVP 11.5)	Mar	42.09	36.39	47.80	45.62	4.2592	N/A	N/A	65.0000			92.00	Option 4: RVP=11.5, ASTM Slope=3
1,2,4-Trimethylbenzene						0.0098	N/A	N/A	120.1900	0.0250	0.0001	120.19	Option 2: A=7.04383, B=1573.267, C=208.56
Benzene						0.6954	N/A	N/A	78.1100	0.0180	0.0042	78.11	Option 2: A=6.905, B=1211.033, C=220.79
Cyclohexane						0.7302	N/A	N/A	84.1600	0.0024	0.0006	84.16	Option 2: A=6.841, B=1201.53, C=222.65
Ethylbenzene						0.0566	N/A	N/A	106.1700	0.0140	0.0003	106.17	Option 2: A=6.975, B=1424.255, C=213.21
Hexane (-n)						1.1768	N/A	N/A	86.1700	0.0100	0.0039	86.17	Option 2: A=6.876, B=1171.17, C=224.41
Isocane							N/A	N/A	114.2200	0.0400	0.0000	114.22	
Isopropyl benzene						0.0238	N/A	N/A	120.2000	0.0050	0.0000	120.20	Option 2: A=6.93666, B=1460.793, C=207.78
Toluene						0.1844	N/A	N/A	92.1300	0.0700	0.0043	92.13	Option 2: A=6.954, B=1344.8, C=219.48
Unidentified Components						5.4887	N/A	N/A	64.7612	0.7458	0.9858	89.36	
Xylene (-m)						0.0468	N/A	N/A	106.1700	0.0700	0.0011	106.17	Option 2: A=7.009, B=1462.266, C=215.11
Gasoline (RVP 9)	Apr	46.48	40.03	52.92	45.62	3.5087	N/A	N/A	67.0000			92.00	Option 4: RVP=9, ASTM Slope=3
1,2,4-Trimethylbenzene						0.0117	N/A	N/A	120.1900	0.0250	0.0001	120.19	Option 2: A=7.04383, B=1573.267, C=208.56
Benzene						0.7928	N/A	N/A	78.1100	0.0180	0.0056	78.11	Option 2: A=6.905, B=1211.033, C=220.79
Cyclohexane						0.8299	N/A	N/A	84.1600	0.0024	0.0008	84.16	Option 2: A=6.841, B=1201.53, C=222.65
Ethylbenzene						0.0667	N/A	N/A	106.1700	0.0140	0.0004	106.17	Option 2: A=6.975, B=1424.255, C=213.21
Hexane (-n)						1.3307	N/A	N/A	86.1700	0.0100	0.0052	86.17	Option 2: A=6.876, B=1171.17, C=224.41





Component	Month	Sample 1	Sample 2	Sample 3	Sample 4	Concentration 1	Concentration 2	Concentration 3	Concentration 4	Concentration 5	Concentration 6	Notes						
Xylene (-m)	Oct	47.76	41.68	53.83	45.62	0.0701	N/A	N/A	106.1700	0.0700	0.0017	106.17	Option 2: A=7.009, B=1462.266, C=215.11					
Gasoline (RVP 10)						4.0663	N/A	N/A	66.0000			92.00	Option 4: RVP=10, ASTM Slope=3					
1,2,4-Trimethylbenzene						0.0123	N/A	N/A	120.1900	0.0250	0.0001	120.19	Option 2: A=7.04383, B=1573.267, C=208.56					
Benzene						0.8233	N/A	N/A	78.1100	0.0180	0.0051	78.11	Option 2: A=6.905, B=1211.033, C=220.79					
Cyclohexane						0.8610	N/A	N/A	84.1600	0.0024	0.0007	84.16	Option 2: A=6.841, B=1201.53, C=222.65					
Ethylbenzene						0.0699	N/A	N/A	106.1700	0.0140	0.0003	106.17	Option 2: A=6.975, B=1424.255, C=213.21					
Hexane (-n)						1.3786	N/A	N/A	86.1700	0.0100	0.0047	86.17	Option 2: A=6.876, B=1171.17, C=224.41					
Isooctane							N/A	N/A	114.2200	0.0400	0.0000	114.22						
Isopropyl benzene						0.0300	N/A	N/A	120.2000	0.0050	0.0001	120.20	Option 2: A=6.93666, B=1460.793, C=207.78					
Toluene						0.2229	N/A	N/A	92.1300	0.0700	0.0053	92.13	Option 2: A=6.954, B=1344.8, C=219.48					
Unidentified Components						5.2260	N/A	N/A	65.7131	0.7456	0.9823	89.36						
Xylene (-m)						0.0580	N/A	N/A	106.1700	0.0700	0.0014	106.17	Option 2: A=7.009, B=1462.266, C=215.11					
Gasoline (RVP 11.5)						Nov	42.09	37.01	47.17	45.62	4.2591	N/A	N/A	65.0000			92.00	Option 4: RVP=11.5, ASTM Slope=3
1,2,4-Trimethylbenzene											0.0096	N/A	N/A	120.1900	0.0250	0.0001	120.19	Option 2: A=7.04383, B=1573.267, C=208.56
Benzene	0.6954	N/A	N/A	78.1100	0.0180						0.0042	78.11	Option 2: A=6.905, B=1211.033, C=220.79					
Cyclohexane	0.7302	N/A	N/A	84.1600	0.0024						0.0006	84.16	Option 2: A=6.841, B=1201.53, C=222.65					
Ethylbenzene	0.0566	N/A	N/A	106.1700	0.0140						0.0003	106.17	Option 2: A=6.975, B=1424.255, C=213.21					
Hexane (-n)	1.1769	N/A	N/A	86.1700	0.0100						0.0039	86.17	Option 2: A=6.876, B=1171.17, C=224.41					
Isooctane		N/A	N/A	114.2200	0.0400						0.0000	114.22						
Isopropyl benzene	0.0238	N/A	N/A	120.2000	0.0050						0.0000	120.20	Option 2: A=6.93666, B=1460.793, C=207.78					
Toluene	0.1844	N/A	N/A	92.1300	0.0700						0.0043	92.13	Option 2: A=6.954, B=1344.8, C=219.48					
Unidentified Components	5.4886	N/A	N/A	64.7612	0.7456						0.9856	89.36						
Xylene (-m)	0.0469	N/A	N/A	106.1700	0.0700						0.0011	106.17	Option 2: A=7.009, B=1462.266, C=215.11					
Gasoline (RVP 13.5)	Dec	38.58	33.87	43.30	45.62						4.7854	N/A	N/A	62.0000			92.00	Option 4: RVP=13.5, ASTM Slope=3
1,2,4-Trimethylbenzene											0.0083	N/A	N/A	120.1900	0.0250	0.0001	120.19	Option 2: A=7.04383, B=1573.267, C=208.56
Benzene											0.8249	N/A	N/A	78.1100	0.0180	0.0035	78.11	Option 2: A=6.905, B=1211.033, C=220.79
Cyclohexane						0.6578	N/A	N/A	84.1600	0.0024	0.0005	84.16	Option 2: A=6.841, B=1201.53, C=222.65					
Ethylbenzene						0.0494	N/A	N/A	106.1700	0.0140	0.0002	106.17	Option 2: A=6.975, B=1424.255, C=213.21					
Hexane (-n)						1.0647	N/A	N/A	86.1700	0.0100	0.0039	86.17	Option 2: A=6.876, B=1171.17, C=224.41					
Isooctane							N/A	N/A	114.2200	0.0400	0.0000	114.22						
Isopropyl benzene						0.0206	N/A	N/A	120.2000	0.0050	0.0000	120.20	Option 2: A=6.93666, B=1460.793, C=207.78					
Toluene						0.1635	N/A	N/A	92.1300	0.0700	0.0035	92.13	Option 2: A=6.954, B=1344.8, C=219.48					
Unidentified Components						6.1804	N/A	N/A	61.7849	0.7456	0.9880	89.36						
Xylene (-m)						0.0409	N/A	N/A	106.1700	0.0700	0.0009	106.17	Option 2: A=7.009, B=1462.266, C=215.11					

## TANKS 4.0.9d Emissions Report - Detail Format Detail Calculations (AP-42)

### Med Bow F&P Gasoline Tank - Internal Floating Roof Tank Medicine Bow, Wyoming

Month:	January	February	March	April	May	June	July	August	September	October	November	December
Rim Seal Losses (lb):	768.6486	696.2795	609.4664	495.7875	554.0962	515.8131	566.2495	540.2813	581.3535	584.1775	609.4595	674.3793
Seal Factor A (lb-mole/ft-yr):	6.7000	6.7000	6.7000	6.7000	6.7000	6.7000	6.7000	6.7000	6.7000	6.7000	6.7000	6.7000
Seal Factor B (lb-mole/ft-yr (mph) <sup>0.5</sup> ):	0.2000	0.2000	0.2000	0.2000	0.2000	0.2000	0.2000	0.2000	0.2000	0.2000	0.2000	0.2000
Value of Vapor Pressure Function:	0.1512	0.1339	0.1120	0.0884	0.0987	0.0906	0.0977	0.0949	0.1036	0.1057	0.1120	0.1299
Vapor Pressure at Daily Average Liquid Surface Temperature (psia):	5.3659	4.8987	4.2592	3.5087	3.8475	3.5821	3.8131	3.7225	4.0013	4.0663	4.2591	4.7864
Tank Diameter (ft):	150.0000	150.0000	150.0000	150.0000	150.0000	150.0000	150.0000	150.0000	150.0000	150.0000	150.0000	150.0000
Vapor Molecular Weight (lb/lb-mole):	60.0000	62.0000	65.0000	67.0000	67.0000	68.0000	68.0000	68.0000	67.0000	66.0000	65.0000	62.0000
Product Factor:	1.0000	1.0000	1.0000	1.0000	1.0000	1.0000	1.0000	1.0000	1.0000	1.0000	1.0000	1.0000
Withdrawal Losses (lb):	4.3540	3.8533	4.1562	3.8993	4.0293	3.8441	3.9723	3.9723	3.8717	4.0788	4.0221	4.2662
Number of Columns:	9.0000	9.0000	9.0000	9.0000	9.0000	9.0000	9.0000	9.0000	9.0000	9.0000	9.0000	9.0000
Effective Column Diameter (ft):	1.0000	1.0000	1.0000	1.0000	1.0000	1.0000	1.0000	1.0000	1.0000	1.0000	1.0000	1.0000
Net Throughput (gal/mo.):	3,266,881.0000	2,891,196.0000	3,118,453.0000	2,925,720.0000	3,023,244.0000	2,884,298.0000	2,980,441.0000	2,980,441.0000	2,905,009.0000	3,060,351.0000	3,017,858.0000	3,200,967.0000
Shell Clingage Factor (bbl/1000 sqft):	0.0015	0.0015	0.0015	0.0015	0.0015	0.0015	0.0015	0.0015	0.0015	0.0015	0.0015	0.0015
Average Organic Liquid Density (lb/gal):	5.6000	5.6000	5.6000	5.6000	5.6000	5.6000	5.6000	5.6000	5.6000	5.6000	5.6000	5.6000
Tank Diameter (ft):	150.0000	150.0000	150.0000	150.0000	150.0000	150.0000	150.0000	150.0000	150.0000	150.0000	150.0000	150.0000
Deck Filling Losses (lb):	938.3361	868.8269	762.8262	612.4085	684.4316	637.1447	687.0927	667.3438	718.1017	721.5900	752.8189	833.0095
Value of Vapor Pressure Function:	0.1512	0.1339	0.1120	0.0884	0.0987	0.0906	0.0977	0.0949	0.1036	0.1057	0.1120	0.1299
Vapor Molecular Weight (lb/lb-mole):	60.0000	62.0000	65.0000	67.0000	67.0000	68.0000	68.0000	68.0000	67.0000	66.0000	65.0000	62.0000
Product Factor:	1.0000	1.0000	1.0000	1.0000	1.0000	1.0000	1.0000	1.0000	1.0000	1.0000	1.0000	1.0000
Tot. Roof Filling Loss Fac.(lb-mole/yr):	1,241.4000	1,241.4000	1,241.4000	1,241.4000	1,241.4000	1,241.4000	1,241.4000	1,241.4000	1,241.4000	1,241.4000	1,241.4000	1,241.4000
Deck Seam Losses (lb):	785.7265	719.1478	630.3877	512.8074	573.1187	533.5204	575.3450	558.8079	601.3108	604.2317	630.3816	697.5301
Deck Seam Length (ft):	5,831.5800	5,831.5800	5,831.5800	5,831.5800	5,831.5800	5,831.5800	5,831.5800	5,831.5800	5,831.5800	5,831.5800	5,831.5800	5,831.5800
Deck Seam Loss per Unit Length Factor (lb-mole/ft-yr):	0.1400	0.1400	0.1400	0.1400	0.1400	0.1400	0.1400	0.1400	0.1400	0.1400	0.1400	0.1400
Deck Seam Length Factor(ft/sqft):	0.3300	0.3300	0.3300	0.3300	0.3300	0.3300	0.3300	0.3300	0.3300	0.3300	0.3300	0.3300
Tank Diameter (ft):	150.0000	150.0000	150.0000	150.0000	150.0000	150.0000	150.0000	150.0000	150.0000	150.0000	150.0000	150.0000
Vapor Molecular Weight (lb/lb-mole):	60.0000	62.0000	65.0000	67.0000	67.0000	68.0000	68.0000	68.0000	67.0000	66.0000	65.0000	62.0000
Product Factor:	1.0000	1.0000	1.0000	1.0000	1.0000	1.0000	1.0000	1.0000	1.0000	1.0000	1.0000	1.0000
<b>Total Losses (lb):</b>	<b>2,488.0652</b>	<b>2,277.1065</b>	<b>1,998.8954</b>	<b>1,624.9027</b>	<b>1,815.6728</b>	<b>1,690.3223</b>	<b>1,822.6595</b>	<b>1,770.3851</b>	<b>1,804.6378</b>	<b>1,914.0780</b>	<b>1,986.6821</b>	<b>2,209.1851</b>

Roof Filling/Status	Quantity	Roof Filling Loss Factors		m	Losses(lb)
		KFa(lb-mole/yr)	KFb(lb-mole/yr mph <sup>0.5</sup> )		
Access Hatch (24-in. Diam.)/Unbolted Cover, Ungasketed	1	36.00	5.90	1.20	256.9292
Automatic Gauge Float Well/Unbolted Cover, Ungasketed	1	14.00	5.40	1.10	99.9169
Column Well (24-in. Diam.)/Bull-Up Col.-Sliding Cover, Ungask.	9	47.00	0.00	0.00	3,018.9184
Ladder Well (36-in. Diam.)/Sliding Cover, Ungasketed	1	76.00	0.00	0.00	542.4061
Roof Leg or Hanger Well/Adjustable	58	7.90	0.00	0.00	3,270.1381
Sample Pipe or Well (24-in. Diam.)/Silt Fabric Seal 10% Open	1	12.00	0.00	0.00	85.8431
Stub Drain (4-in. Diameter)	180	1.20	0.00	0.00	1,541.5754
Vacuum Breaker (10-in. Diam.)/Weighted Mech. Actuation, Gask.	1	6.20	1.20	0.94	44.2489

**TANKS 4.0.9d  
Emissions Report - Detail Format  
Individual Tank Emission Totals**

**Emissions Report for: Annual**

**Med Bow F&P Gasoline Tank - Internal Floating Roof Tank  
Medicine Bow, Wyoming**

Components	Losses(lbs)				Total Emissions
	Rim Seal Loss	Withdrawal Loss	Deck Fitting Loss	Deck Seam Loss	
Gasoline (RVP 13.5)	1,369.66	8.12	1,691.84	1,416.68	4,486.29
1,2,4-Trimethylbenzene	0.09	0.20	0.11	0.09	0.49
Benzene	4.81	0.15	5.94	4.97	15.86
Cyclohexane	0.67	0.02	0.83	0.70	2.22
Ethylbenzene	0.30	0.11	0.37	0.31	1.09
Hexane (-n)	4.54	0.08	5.61	4.70	14.94
Isooctane	0.00	0.32	0.00	0.00	0.32
Isopropyl benzene	0.04	0.04	0.05	0.05	0.19
Toluene	4.90	0.57	6.06	5.07	16.60
Unidentified Components	1,353.07	6.05	1,671.35	1,399.52	4,429.99
Xylene (-m)	1.23	0.57	1.52	1.27	4.58
Gasoline (RVP 15.0)	759.65	4.35	938.34	785.73	2,488.07
1,2,4-Trimethylbenzene	0.04	0.11	0.05	0.05	0.25
Benzene	2.41	0.08	2.97	2.49	7.95
Cyclohexane	0.34	0.01	0.42	0.35	1.12
Ethylbenzene	0.15	0.06	0.18	0.15	0.54
Hexane (-n)	2.28	0.04	2.82	2.36	7.50
Isooctane	0.00	0.17	0.00	0.00	0.17
Isopropyl benzene	0.02	0.02	0.03	0.02	0.09
Toluene	2.44	0.30	3.02	2.53	8.30
Unidentified Components	751.36	3.25	928.09	777.15	2,459.85
Xylene (-m)	0.61	0.30	0.75	0.63	2.30
Gasoline (RVP 11.5)	1,218.92	8.18	1,505.65	1,260.77	3,993.52
1,2,4-Trimethylbenzene	0.10	0.20	0.12	0.10	0.52



Hexane (-n)	2.76	0.04	3.41	2.86	9.07
Isoclane	0.00	0.16	0.00	0.00	0.16
Isopropyl benzene	0.03	0.02	0.04	0.03	0.12
Toluene	3.13	0.29	3.86	3.23	10.50
Unidentified Components	573.81	3.04	708.78	593.51	1,879.14
Xylene (-m)	0.81	0.29	1.00	0.84	2.94

## TANKS 4.0.9d

### Emissions Report - Detail Format

### Tank Identification and Physical Characteristics

**Identification**

User Identification: Med Bow F&P MeOH Tank  
 City: Medicine Bow  
 State: Wyoming  
 Company: Medicine Bow Fuel & Power LLC  
 Type of Tank: Internal Floating Roof Tank  
 Description: Methanol tank; total 2 identical tanks.

**Tank Dimensions**

Diameter (ft): 150.00  
 Volume (gallons): 6,341,984.00  
 Turnovers: 4.00  
 Self Supp. Roof? (y/n): N  
 No. of Columns: 9.00  
 Eff. Col. Diam. (ft): 1.00

**Paint Characteristics**

Internal Shell Condition: Light Rust  
 Shell Color/Shade: White/White  
 Shell Condition: Good  
 Roof Color/Shade: White/White  
 Roof Condition: Good

**Rim-Seal System**

Primary Seal: Vapor-mounted  
 Secondary Seal: None

**Deck Characteristics**

Deck Fitting Category: Typical  
 Deck Type: Bolted  
 Construction: Panel  
 Deck Seam: Panel: 5 x 7.5 Ft  
 Deck Seam Len. (ft): 5,831.58

**Deck Fitting/Status**

**Quantity**

Access Hatch (24-in. Diam.)/Unbolted Cover, Ungasketed	1
Automatic Gauge Float Well/Unbolted Cover, Ungasketed	1
Column Well (24-in. Diam.)/Built-Up Col.-Sliding Cover, Ungask.	9
Ladder Well (36-in. Diam.)/Sliding Cover, Ungasketed	1
Roof Leg or Hanger Well/Adjustable	58
Sample Pipe or Well (24-in. Diam.)/Slit Fabric Seal 10% Open	1
Stub Drain (1-in. Diameter)/Slit Fabric Seal 10% Open	180

Vacuum Breaker (10-in. Diam.)/Weighted Mech. Actuation, Gask.

1

Meterological Data used in Emissions Calculations: Cheyenne, Wyoming (Avg Atmospheric Pressure = 11.76 psia)

**TANKS 4.0.9d**  
**Emissions Report - Detail Format**  
**Liquid Contents of Storage Tank**

**Med Bow F&P MeOH Tank - Internal Floating Roof Tank**  
**Medicine Bow, Wyoming**

Mixture/Component	Month	Daily Liquid Surf. Temperature (deg F)			Liquid Bulk Temp (deg F)	Vapor Pressure (psia)			Vapor Mol. Weight.	Liquid Mass Fract.	Vapor Mass Fract.	Mol. Weight	Basis for Vapor Pressure Calculations
		Avg.	Min.	Max.		Avg.	Min.	Max.					
Methyl alcohol	AI	47.49	41.37	53.62	46.62	0.9814	N/A	N/A	32.0400			32.04	Option 2: A=7.897, B=1474.08, C=228.13



## TANKS 4.0.9d Emissions Report - Detail Format Detail Calculations (AP-42)

### Med Bow F&P MeOH Tank - Internal Floating Roof Tank Medicine Bow, Wyoming

Annual Emission Calculations

Rim Seal Losses (lb):	886.4952
Seal Factor A (lb-mole/ft-yr):	6.7000
Seal Factor B (lb-mole/ft-yr (mph) <sup>2</sup> n):	0.2000
Value of Vapor Pressure Function:	0.0213
Vapor Pressure at Daily Average Liquid Surface Temperature (psia):	0.9614
Tank Diameter (ft):	150.0000
Vapor Molecular Weight (lb/lb-mole):	32.0400
Product Factor:	1.0000
Withdrawal Losses (lb):	40.0283
Number of Columns:	9.0000
Effective Column Diameter (ft):	1.0000
Annual Net Throughput (gal/yr.):	25,367,936.0000
Shell Clingage Factor (bbl/1000 sqft):	0.0015
Average Organic Liquid Density (lb/gal):	6.6300
Tank Diameter (ft):	150.0000
Deck Filling Losses (lb):	847.9752
Value of Vapor Pressure Function:	0.0213
Vapor Molecular Weight (lb/lb-mole):	32.0400
Product Factor:	1.0000
Tot. Roof Filling Loss Fact.(lb-mole/yr):	1,241.4000
Deck Seam Losses (lb):	710.0619
Deck Seam Length (ft):	5,831.5800
Deck Seam Loss per Unit Length Factor (lb-mole/ft-yr):	0.1400
Deck Seam Length Factor(ft/sqft):	0.3300
Tank Diameter (ft):	150.0000
Vapor Molecular Weight (lb/lb-mole):	32.0400
Product Factor:	1.0000
<b>Total Losses (lb):</b>	<b>2,284.5806</b>

Roof Fitting/Status	Quantity	Roof Fitting Loss Factors		m	Losses(lb)
		KFa(lb-mole/yr)	KFb(lb-mole/(yr mph <sup>2</sup> n))		
Access Hatch (24-in. Diam.)/Unbolted Cover, Ungasketed	1	36.00	5.90	1.20	24.5909
Automatic Gauge Float Well/Unbolted Cover, Ungasketed	1	14.00	5.40	1.10	9.5631
Column Well (24-in. Diam.)/Bull-Up Col.-Sliding Cover, Ungask.	9	47.00	0.00	0.00	288.9427
Ladder Well (36-in. Diam.)/Sliding Cover, Ungasketed	1	76.00	0.00	0.00	51.9141
Roof Leg or Hanger Well/Adjustable	58	7.80	0.00	0.00	312.9872
Sample Pipe or Well (24-in. Diam.)/Silt Fabric Seal 10% Open	1	12.00	0.00	0.00	8.1970
Stub Drain (1-in. Diameter)/	180	1.20	0.00	0.00	147.5452
Vacuum Breaker (10-in. Diam.)/Weighted Mech. Actuation, Gask.	1	6.20	1.20	0.94	4.2351

**TANKS 4.0.9d**  
**Emissions Report - Detail Format**  
**Individual Tank Emission Totals**

**Emissions Report for: Annual**

**Med Bow F&P MeOH Tank - Internal Floating Roof Tank**  
**Medicine Bow, Wyoming**

Components	Losses(lbs)				Total Emissions
	Rim Seal Loss	Withdrawl Loss	Deck Fitting Loss	Deck Seam Loss	
Methyl alcohol	686.50	40.03	847.98	710.06	2,284.58

## TANKS 4.0.9d

### Emissions Report - Detail Format

#### Tank Identification and Physical Characteristics

**Identification**

User Identification: Med Bow F&P Hwy Gaso Tank  
 City: Medicine Bow  
 State: Wyoming  
 Company: Medicine Bow Fuel & Power LLC  
 Type of Tank: Internal Floating Roof Tank  
 Description: Heavy Gasoline Tank

**Tank Dimensions**

Diameter (ft): 130.00  
 Volume (gallons): 4,763,841.00  
 Turnovers: 7.72  
 Self Supp. Roof? (y/n): N  
 No. of Columns: 8.00  
 Eff. Col. Diam. (ft): 1.00

**Paint Characteristics**

Internal Shell Condition: Light Rust  
 Shell Color/Shade: White/White  
 Shell Condition: Good  
 Roof Color/Shade: White/White  
 Roof Condition: Good

**Rim-Seal System**

Primary Seal: Vapor-mounted  
 Secondary Seal: None

**Deck Characteristics**

Deck Fitting Category: Typical  
 Deck Type: Bolted  
 Construction: Panel  
 Deck Seam: Panel: 5 x 7.5 Ft  
 Deck Seam Len. (ft): 4,380.16

**Deck Fitting/Status**

**Quantity**

Access Hatch (24-in. Diam.)/Unbolted Cover, Ungasketed	1
Automatic Gauge Float Well/Unbolted Cover, Ungasketed	1
Column Well (24-in. Diam.)/Built-Up Col.-Sliding Cover, Ungask.	8
Ladder Well (36-in. Diam.)/Sliding Cover, Ungasketed	1
Roof Leg or Hanger Well/Adjustable	47
Sample Pipe or Well (24-in. Diam.)/Silt Fabric Seal 10% Open	1
Stub Drain (1-in. Diameter)/Silt Fabric Seal 10% Open	136

Vacuum Breaker (10-in. Diam.)/Weighted Mech. Actuation, Gask.

1

Meteorological Data used in Emissions Calculations: Cheyenne, Wyoming (Avg Atmospheric Pressure = 11.76 psia)

### TANKS 4.0.9d Emissions Report - Detail Format Liquid Contents of Storage Tank

**Med Bow F&P Hvy Gaso Tank - Internal Floating Roof Tank  
Medicine Bow, Wyoming**

Mixture/Component	Month	Daily Liquid Surf. Temperature (deg F)			Liquid Bulk Temp (deg F)	Vapor Pressure (psia)			Vapor Mol. Weight	Liquid Mass Fract.	Vapor Mass Fract.	Mol. Weight	Basis for Vapor Pressure Calculations
		Avg.	Min.	Max.		Avg.	Min.	Max.					
Gasoline (RVP 6)	All	47.49	41.37	53.62	46.62	2.2481	N/A	N/A	69.0000			92.00	Option 4: RVP=6, ASTM Slope=3
1,2,4-Trimethylbenzene						0.0122	N/A	N/A	120.1900	0.0250	0.0002	120.19	Option 2: A=7.04383, B=1573.267, C=208.56
Benzene						0.8169	N/A	N/A	78.1100	0.0180	0.0087	78.11	Option 2: A=6.905, B=1211.033, C=220.79
Cyclohexane						0.8545	N/A	N/A	84.1600	0.0024	0.0012	84.16	Option 2: A=6.841, B=1201.53, C=222.65
Ethylbenzene						0.0693	N/A	N/A	106.1700	0.0140	0.0006	106.17	Option 2: A=6.975, B=1424.255, C=213.21
Hexane (n)						1.3685	N/A	N/A	86.1700	0.0100	0.0081	86.17	Option 2: A=6.876, B=1171.17, C=224.41
Isooctane							N/A	N/A	114.2200	0.0400	0.0000	114.22	
Isopropyl benzene						0.0297	N/A	N/A	120.2000	0.0050	0.0001	120.20	Option 2: A=6.93666, B=1460.793, C=207.78
Toluene						0.2210	N/A	N/A	92.1300	0.0700	0.0092	92.13	Option 2: A=6.954, B=1344.8, C=219.48
Unidentified Components						2.8580	N/A	N/A	68.5540	0.7466	0.9695	89.36	
Xylene (m)						0.0574	N/A	N/A	106.1700	0.0700	0.0024	106.17	Option 2: A=7.008, B=1462.266, C=215.11

## TANKS 4.0.9d

### Emissions Report - Detail Format

#### Detail Calculations (AP-42)

### Med Bow F&P Hvy Gaso Tank - Internal Floating Roof Tank Medicine Bow, Wyoming

Annual Emission Calculations

Rim Seal Losses (lb):	3,184.8748
Seal Factor A (lb-mole/ft-yr):	8.7000
Seal Factor B (lb-mole/ft-yr (mph) <sup>1/2</sup> n):	0.2000
Value of Vapor Pressure Function:	0.0530
Vapor Pressure at Daily Average Liquid Surface Temperature (psia):	2.2481
Tank Diameter (ft):	130.0000
Vapor Molecular Weight (lb/lb-mole):	69.0000
Product Factor:	1.0000
Withdrawal Losses (lb):	58.8142
Number of Columns:	8.0000
Effective Column Diameter (ft):	1.0000
Annual Net Throughput (gal/yr):	36,761,340.0000
Shell Clingage Factor (bb/1000 sqft):	0.0015
Average Organic Liquid Density (lb/gal):	5.6000
Tank Diameter (ft):	130.0000
Deck Filling Losses (lb):	3,856.5869
Value of Vapor Pressure Function:	0.0530
Vapor Molecular Weight (lb/lb-mole):	69.0000
Product Factor:	1.0000
Tot. Roof Filling Loss Fact.(lb-mole/yr):	1,054.7000
Deck Seam Losses (lb):	2,854.8706
Deck Seam Length (ft):	4,380.1619
Deck Seam Loss per Unit Length Factor (lb-mole/ft-yr):	0.1400
Deck Seam Length Factor (ft/sqft):	0.3300
Tank Diameter (ft):	130.0000
Vapor Molecular Weight (lb/lb-mole):	69.0000
Product Factor:	1.0000
<b>Total Losses (lb):</b>	<b>6,983.0542</b>

Roof Fitting/Status	Quantity	KFa(lb-mole/yr)	Roof Filling Loss Factors KFb(lb-mole/(yr mph <sup>1/2</sup> n))	m	Losses(lb)
Access Hatch (24-in. Diam.)/Unbolted Cover, Ungasketed	1	38.00	5.90	1.20	131.8388
Automatic Gauge Float Well/Unbolted Cover, Ungasketed	1	14.00	5.40	1.10	51.1920
Column Wall (24-in. Diam.)/Built-Up Col.-Sliding Cover, Ungask.	8	47.00	0.00	0.00	1,374.8712
Ladder Wall (36-in. Diam.)/Sliding Cover, Ungasketed	1	76.00	0.00	0.00	277.8995
Roof Leg or Hanger Well/Adjustable	47	7.00	0.00	0.00	1,357.8853
Sample Pipe or Well (24-in. Diam.)/Slit Fabric Seal 10% Open	1	12.00	0.00	0.00	43.8789
Stub Drain (1-in. Diameter)	136	1.20	0.00	0.00	606.7526
Vacuum Breaker (10-in. Diam.)/Weighted Mech. Actuation, Gask.	1	6.20	1.20	0.94	22.6707

**TANKS 4.0.9d  
Emissions Report - Detail Format  
Individual Tank Emission Totals**

**Emissions Report for: Annual**

**Med Bow F&P Hvy Gaso Tank - Internal Floating Roof Tank  
Medicine Bow, Wyoming**

Components	Losses(lbs)				Total Emissions
	Rim Seal Loss	Withdrawl Loss	Deck Fitting Loss	Deck Seam Loss	
Gasoline (RVP:6)	3,184.87	56.61	3,856.59	2,854.98	9,953.05
Hexane (-n)	25.85	0.57	31.30	23.17	80.89
Benzene	27.77	1.02	33.63	24.90	87.32
Isooctane	0.00	2.26	0.00	0.00	2.26
Toluene	29.22	3.96	35.38	26.19	94.76
Ethylbenzene	1.83	0.79	2.22	1.64	6.48
Xylene (-m)	7.59	3.96	9.20	6.81	27.56
Isopropyl benzene	0.28	0.28	0.34	0.25	1.15
1,2,4-Trimethylbenzene	0.58	1.42	0.70	0.52	3.20
Cyclohexane	3.87	0.14	4.69	3.47	12.17
Unidentified Components	3,087.87	42.21	3,739.13	2,768.03	9,637.24

### TANKS 4.0.9d Emissions Report - Detail Format Tank Identification and Physical Characteristics

**Identification**

User Identification: Med Bow F&P Gasoline Off-Spec Tank  
 City: Medicine Bow  
 State: Wyoming  
 Company: Medicine Bow Fuel & Power LLC  
 Type of Tank: Internal Floating Roof Tank  
 Description: Gasoline Off-Spec Tank

**Tank Dimensions**

Diameter (ft): 8.50  
 Volume (gallons): 5,000.00  
 Turnovers: 5.72  
 Self Supp. Roof? (y/n): N  
 No. of Columns: 1.00  
 Eff. Col. Diam. (ft): 1.00

**Paint Characteristics**

Internal Shell Condition: Light Rust  
 Shell Color/Shade: White/White  
 Shell Condition: Good  
 Roof Color/Shade: White/White  
 Roof Condition: Good

**Rim-Seal System**

Primary Seal: Vapor-mounted  
 Secondary Seal: None

**Deck Characteristics**

Deck Fitting Category: Typical  
 Deck Type: Bolted  
 Construction: Panel  
 Deck Seam: Panel: 5 x 7.5 Ft  
 Deck Seam Len. (ft): 18.73

**Deck Fitting/Status**

**Quantity**

Access Hatch (24-in. Diam.)/Unbolted Cover, Ungasketed	1
Automatic Gauge Float Well/Unbolted Cover, Ungasketed	1
Column Well (24-in. Diam.)/Bull-Up Col.-Sliding Cover, Ungask.	1
Ladder Well (36-in. Diam.)/Sliding Cover, Ungasketed	1
Roof Leg or Hanger Well/Adjustable	6
Sample Pipe or Well (24-in. Diam.)/Slit Fabric Seal 10% Open	1
Stub Drain (1-in. Diameter)/Slit Fabric Seal 10% Open	1



Vacuum Breaker (10-in. Diam.)/Weighted Mech. Actuation, Gask.

1

Meteorological Data used in Emissions Calculations: Cheyenne, Wyoming (Avg Atmospheric Pressure = 11.76 psia)

## TANKS 4.0.9d

### Emissions Report - Detail Format

### Liquid Contents of Storage Tank

**Med Bow F&P Gasoline Off-Spec Tank - Internal Floating Roof Tank**  
**Medicine Bow, Wyoming**

Mixture/Component	Month	Daily Liquid Surf. Temperature (deg F)			Liquid Bulk Temp (deg F)	Vapor Pressure (psia)			Vapor Mol. Weight	Liquid Mass Fract.	Vapor Mass Fract.	Mol. Weight	Basis for Vapor Pressure Calculations
		Avg.	Min.	Max.		Avg.	Min.	Max.					
Gasoline (RVP 15.0)	Jan	38.11	33.24	42.99	45.62	6.3659	N/A	N/A	60.0000	0.0250	0.0001	92.00	Option 4: RVP=15, ASTM Slope=3
1,2,4-Trimethylbenzene						0.0081	N/A	N/A	120.1900	0.0180	0.0032	120.19	Option 2: A=7.04383, B=1573.267, C=208.56
Benzene						0.6159	N/A	N/A	78.1100	0.0024	0.0004	78.11	Option 2: A=6.905, B=1211.033, C=220.79
Cyclohexane						0.6488	N/A	N/A	84.1600	0.0100	0.0030	84.16	Option 2: A=6.841, B=1201.53, C=222.65
Ethylbenzene						0.0485	N/A	N/A	106.1700	0.0400	0.0000	106.17	Option 2: A=6.975, B=1424.255, C=213.21
Hexane (-n)						1.0503	N/A	N/A	86.1700	0.0400	0.0000	86.17	Option 2: A=6.876, B=1171.17, C=224.41
Isooctane							N/A	N/A	114.2200	0.0050	0.0000	114.22	
Isopropyl benzene						0.0202	N/A	N/A	120.2000	0.0700	0.0032	120.20	Option 2: A=6.93666, B=1460.793, C=207.78
Toluene						0.1609	N/A	N/A	92.1300	0.7466	0.9891	92.13	Option 2: A=6.954, B=1344.8, C=219.48
Unidentified Components						6.9376	N/A	N/A	59.7961	0.0700	0.0008	89.36	
Xylene (-m)						0.0401	N/A	N/A	106.1700	0.0700	0.0009	106.17	Option 2: A=7.009, B=1462.266, C=215.11
Gasoline (RVP 13.5)	Feb	39.75	34.55	44.94	45.62	4.8987	N/A	N/A	62.0000	0.0250	0.0001	92.00	Option 4: RVP=13.5, ASTM Slope=3
1,2,4-Trimethylbenzene						0.0087	N/A	N/A	120.1900	0.0180	0.0032	120.19	Option 2: A=7.04383, B=1573.267, C=208.56
Benzene						0.6475	N/A	N/A	78.1100	0.0024	0.0005	78.11	Option 2: A=6.905, B=1211.033, C=220.79
Cyclohexane						0.6811	N/A	N/A	84.1600	0.0100	0.0005	84.16	Option 2: A=6.841, B=1201.53, C=222.65
Ethylbenzene						0.0517	N/A	N/A	106.1700	0.0100	0.0002	106.17	Option 2: A=6.975, B=1424.255, C=213.21
Hexane (-n)						1.1008	N/A	N/A	86.1700	0.0100	0.0033	86.17	Option 2: A=6.876, B=1171.17, C=224.41
Isooctane							N/A	N/A	114.2200	0.0400	0.0000	114.22	
Isopropyl benzene						0.0216	N/A	N/A	120.2000	0.0050	0.0000	120.20	Option 2: A=6.93666, B=1460.793, C=207.78
Toluene						0.1702	N/A	N/A	92.1300	0.0700	0.0035	92.13	Option 2: A=6.954, B=1344.8, C=219.48
Unidentified Components						6.3261	N/A	N/A	61.7817	0.7466	0.9878	89.36	
Xylene (-m)						0.0428	N/A	N/A	106.1700	0.0700	0.0009	106.17	Option 2: A=7.009, B=1462.266, C=215.11
Gasoline (RVP 11.5)	Mar	42.09	36.39	47.80	45.62	4.2592	N/A	N/A	65.0000	0.0250	0.0001	92.00	Option 4: RVP=11.5, ASTM Slope=3
1,2,4-Trimethylbenzene						0.0086	N/A	N/A	120.1900	0.0180	0.0032	120.19	Option 2: A=7.04383, B=1573.267, C=208.56
Benzene						0.6954	N/A	N/A	78.1100	0.0024	0.0004	78.11	Option 2: A=6.905, B=1211.033, C=220.79
Cyclohexane						0.7302	N/A	N/A	84.1600	0.0100	0.0006	84.16	Option 2: A=6.841, B=1201.53, C=222.65
Ethylbenzene						0.0506	N/A	N/A	106.1700	0.0100	0.0003	106.17	Option 2: A=6.975, B=1424.255, C=213.21
Hexane (-n)						1.1768	N/A	N/A	86.1700	0.0100	0.0039	86.17	Option 2: A=6.876, B=1171.17, C=224.41
Isooctane							N/A	N/A	114.2200	0.0400	0.0000	114.22	
Isopropyl benzene						0.0238	N/A	N/A	120.2000	0.0050	0.0000	120.20	Option 2: A=6.93666, B=1460.793, C=207.78
Toluene						0.1844	N/A	N/A	92.1300	0.0700	0.0043	92.13	Option 2: A=6.954, B=1344.8, C=219.48
Unidentified Components						5.4887	N/A	N/A	64.7612	0.7466	0.9858	89.36	
Xylene (-m)						0.0468	N/A	N/A	106.1700	0.0700	0.0011	106.17	Option 2: A=7.009, B=1462.266, C=215.11
Gasoline (RVP 9)	Apr	46.48	40.03	52.92	45.62	3.5087	N/A	N/A	67.0000	0.0250	0.0001	92.00	Option 4: RVP=9, ASTM Slope=3
1,2,4-Trimethylbenzene						0.0117	N/A	N/A	120.1900	0.0180	0.0032	120.19	Option 2: A=7.04383, B=1573.267, C=208.56
Benzene						0.7928	N/A	N/A	78.1100	0.0024	0.0006	78.11	Option 2: A=6.905, B=1211.033, C=220.79
Cyclohexane						0.8299	N/A	N/A	84.1600	0.0100	0.0008	84.16	Option 2: A=6.841, B=1201.53, C=222.65
Ethylbenzene						0.0667	N/A	N/A	106.1700	0.0100	0.0004	106.17	Option 2: A=6.975, B=1424.255, C=213.21
Hexane (-n)						1.3307	N/A	N/A	86.1700	0.0100	0.0052	86.17	Option 2: A=6.876, B=1171.17, C=224.41



Xylene (m)					0.0701	N/A	N/A	106.1700	0.0700	0.0017	106.17	Option 2: A=7.009, B=1462.266, C=215.11	
Gasoline (RVP 10)	Oct	47.76	41.68	53.83	45.62	4.0863	N/A	N/A	66.0000		92.00	Option 4: RVP=10, ASTM Slope=3	
1,2,4-Trimethylbenzene						0.0123	N/A	N/A	120.1900	0.0250	0.0001	120.19	Option 2: A=7.04383, B=1573.267, C=208.56
Benzene						0.8233	N/A	N/A	78.1100	0.0180	0.0051	78.11	Option 2: A=6.905, B=1211.033, C=220.79
Cyclohexane						0.8610	N/A	N/A	84.1600	0.0024	0.0007	84.16	Option 2: A=6.041, B=1201.53, C=222.65
Ethylbenzene						0.0599	N/A	N/A	106.1700	0.0140	0.0003	106.17	Option 2: A=6.975, B=1424.255, C=213.21
Hexane (n)						1.3786	N/A	N/A	86.1700	0.0100	0.0047	86.17	Option 2: A=6.876, B=1171.17, C=224.41
Isooctane							N/A	N/A	114.2200	0.0400	0.0000	114.22	
Isopropyl benzene						0.0300	N/A	N/A	120.2000	0.0050	0.0001	120.20	Option 2: A=6.93666, B=1460.793, C=207.70
Toluene						0.2229	N/A	N/A	92.1300	0.0700	0.0053	92.13	Option 2: A=6.954, B=1344.8, C=219.48
Unidentified Components						5.2260	N/A	N/A	65.7131	0.7456	0.9823	89.36	
Xylene (m)						0.0680	N/A	N/A	106.1700	0.0700	0.0014	106.17	Option 2: A=7.009, B=1462.266, C=215.11
Gasoline (RVP 11.5)	Nov	42.09	37.01	47.17	45.62	4.2591	N/A	N/A	65.0000			92.00	Option 4: RVP=11.5, ASTM Slope=3
1,2,4-Trimethylbenzene						0.0096	N/A	N/A	120.1900	0.0250	0.0001	120.19	Option 2: A=7.04383, B=1573.267, C=208.56
Benzene						0.6954	N/A	N/A	78.1100	0.0180	0.0042	78.11	Option 2: A=6.905, B=1211.033, C=220.79
Cyclohexane						0.7302	N/A	N/A	84.1600	0.0024	0.0006	84.16	Option 2: A=6.041, B=1201.53, C=222.65
Ethylbenzene						0.0566	N/A	N/A	106.1700	0.0140	0.0003	106.17	Option 2: A=6.975, B=1424.255, C=213.21
Hexane (n)						1.1766	N/A	N/A	86.1700	0.0100	0.0039	86.17	Option 2: A=6.876, B=1171.17, C=224.41
Isooctane							N/A	N/A	114.2200	0.0400	0.0000	114.22	
Isopropyl benzene						0.0238	N/A	N/A	120.2000	0.0050	0.0000	120.20	Option 2: A=6.93666, B=1460.793, C=207.78
Toluene						0.1844	N/A	N/A	92.1300	0.0700	0.0043	92.13	Option 2: A=6.954, B=1344.8, C=219.48
Unidentified Components						5.4866	N/A	N/A	64.7612	0.7456	0.9856	89.36	
Xylene (m)						0.0468	N/A	N/A	106.1700	0.0700	0.0011	106.17	Option 2: A=7.009, B=1462.266, C=215.11
Gasoline (RVP 13.5)	Dec	38.58	33.87	43.30	45.62	4.7854	N/A	N/A	62.0000			92.00	Option 4: RVP=13.5, ASTM Slope=3
1,2,4-Trimethylbenzene						0.0089	N/A	N/A	120.1900	0.0250	0.0001	120.19	Option 2: A=7.04383, B=1573.267, C=208.56
Benzene						0.6249	N/A	N/A	78.1100	0.0180	0.0035	78.11	Option 2: A=6.905, B=1211.033, C=220.79
Cyclohexane						0.8578	N/A	N/A	84.1600	0.0024	0.0005	84.16	Option 2: A=6.041, B=1201.53, C=222.65
Ethylbenzene						0.0494	N/A	N/A	106.1700	0.0140	0.0002	106.17	Option 2: A=6.975, B=1424.255, C=213.21
Hexane (n)						1.0847	N/A	N/A	86.1700	0.0100	0.0033	86.17	Option 2: A=6.876, B=1171.17, C=224.41
Isooctane							N/A	N/A	114.2200	0.0400	0.0000	114.22	
Isopropyl benzene						0.0206	N/A	N/A	120.2000	0.0050	0.0000	120.20	Option 2: A=6.93666, B=1460.793, C=207.78
Toluene						0.1635	N/A	N/A	92.1300	0.0700	0.0035	92.13	Option 2: A=6.954, B=1344.8, C=219.48
Unidentified Components						6.1804	N/A	N/A	61.7849	0.7456	0.9880	89.36	
Xylene (m)						0.0409	N/A	N/A	106.1700	0.0700	0.0009	106.17	Option 2: A=7.009, B=1462.266, C=215.11

### TANKS 4.0.9d Emissions Report - Detail Format Detail Calculations (AP-42)

**Med Bow F&P Gasoline Off-Spec Tank - Internal Floating Roof Tank  
Medicine Bow, Wyoming**

Month:	January	February	March	April	May	June	July	August	September	October	November	December
Rim Seal Losses (lb):	43.0468	39.3892	34.5364	28.0948	31.3987	29.2284	31.5208	30.6148	32.9434	33.1034	34.5360	38.2148
Seal Factor A (lb-mole/l-yr):	6.7000	6.7000	6.7000	6.7000	6.7000	6.7000	6.7000	6.7000	6.7000	6.7000	6.7000	6.7000
Seal Factor B (lb-mole/l-yr (mph) <sup>2</sup> n):	0.2000	0.2000	0.2000	0.2000	0.2000	0.2000	0.2000	0.2000	0.2000	0.2000	0.2000	0.2000
Value of Vapor Pressure Function:	0.1512	0.1339	0.1120	0.0884	0.0987	0.0908	0.0977	0.0949	0.1036	0.1057	0.1120	0.1289
Vapor Pressure at Daily Average Liquid Surface Temperature (psia):	5.3659	4.8987	4.2592	3.5087	3.8475	3.5921	3.8131	3.7225	4.0013	4.0863	4.2591	4.7854
Tank Diameter (ft):	8.5000	8.5000	8.5000	8.5000	8.5000	8.5000	8.5000	8.5000	8.5000	8.5000	8.5000	8.5000
Vapor Molecular Weight (lb/lb-mole):	60.0000	62.0000	65.0000	67.0000	67.0000	69.0000	68.0000	68.0000	67.0000	66.0000	65.0000	62.0000
Product Factor:	1.0000	1.0000	1.0000	1.0000	1.0000	1.0000	1.0000	1.0000	1.0000	1.0000	1.0000	1.0000
Withdrawal Losses (lb):	0.0620	0.0620	0.0620	0.0620	0.0620	0.0620	0.0620	0.0620	0.0620	0.0620	0.0620	0.0620
Number of Columns:	1.0000	1.0000	1.0000	1.0000	1.0000	1.0000	1.0000	1.0000	1.0000	1.0000	1.0000	1.0000
Effective Column Diameter (ft):	1.0000	1.0000	1.0000	1.0000	1.0000	1.0000	1.0000	1.0000	1.0000	1.0000	1.0000	1.0000
Nel Throughput (gal/mc.):	2,500.0000	2,500.0000	2,500.0000	2,500.0000	2,500.0000	2,500.0000	2,500.0000	2,500.0000	2,500.0000	2,500.0000	2,500.0000	2,500.0000
Shell Clearance Factor (bb/1000 sqft):	0.0015	0.0015	0.0015	0.0015	0.0015	0.0015	0.0015	0.0015	0.0015	0.0015	0.0015	0.0015
Average Organic Liquid Density (lb/gal):	5.8000	5.8000	5.8000	5.8000	5.8000	5.8000	5.8000	5.8000	5.8000	5.8000	5.8000	5.8000
Tank Diameter (ft):	8.5000	8.5000	8.5000	8.5000	8.5000	8.5000	8.5000	8.5000	8.5000	8.5000	8.5000	8.5000
Deck Filling Losses (lb):	181.2674	165.8985	145.4227	118.2983	132.2110	123.0768	132.7250	128.9101	138.7150	139.3888	145.4213	160.9116
Value of Vapor Pressure Function:	0.1512	0.1339	0.1120	0.0884	0.0987	0.0908	0.0977	0.0949	0.1036	0.1057	0.1120	0.1289
Vapor Molecular Weight (lb/lb-mole):	60.0000	62.0000	65.0000	67.0000	67.0000	68.0000	68.0000	68.0000	67.0000	66.0000	65.0000	62.0000
Product Factor:	1.0000	1.0000	1.0000	1.0000	1.0000	1.0000	1.0000	1.0000	1.0000	1.0000	1.0000	1.0000
Tot. Roof Filling Loss Fact. (lb-mole/yr):	239.8000	239.8000	239.8000	239.8000	239.8000	239.8000	239.8000	239.8000	239.8000	239.8000	239.8000	239.8000
Deck Seam Losses (lb):	2.5231	2.3083	2.0242	1.6407	1.8403	1.7132	1.8475	1.7944	1.8309	1.8403	2.0242	2.2398
Deck Seam Length (ft):	18.7258	18.7258	18.7258	18.7258	18.7258	18.7258	18.7258	18.7258	18.7258	18.7258	18.7258	18.7258
Deck Seam Loss per Unit Length Factor (lb-mole/l-yr):	0.1400	0.1400	0.1400	0.1400	0.1400	0.1400	0.1400	0.1400	0.1400	0.1400	0.1400	0.1400
Deck Seam Length Factor (ft/sqft):	0.3300	0.3300	0.3300	0.3300	0.3300	0.3300	0.3300	0.3300	0.3300	0.3300	0.3300	0.3300
Tank Diameter (ft):	8.5000	8.5000	8.5000	8.5000	8.5000	8.5000	8.5000	8.5000	8.5000	8.5000	8.5000	8.5000
Vapor Molecular Weight (lb/lb-mole):	60.0000	62.0000	65.0000	67.0000	67.0000	68.0000	68.0000	68.0000	67.0000	66.0000	65.0000	62.0000
Product Factor:	1.0000	1.0000	1.0000	1.0000	1.0000	1.0000	1.0000	1.0000	1.0000	1.0000	1.0000	1.0000
Total Losses (lb):	226.8892	207.6890	182.0459	148.1016	165.5120	154.0812	166.1853	161.3913	173.6512	174.4945	182.0435	201.4283

Roof Filling/Status	Quantity	KFa (lb-mole/yr)	Roof Filling Loss Factors KFB (lb-mole/(yr mph <sup>2</sup> n))	m	Losses (lb)
Access Hatch (24-in. Diam.)/Unbolted Cover, Ungasketed	1	39.00	5.90	1.20	286.9292
Automatic Gauge Float Well/Unbolted Cover, Ungasketed	1	14.00	5.40	1.10	99.9189
Column Well (24-in. Diam.)/Bull-Up Col.-Sliding Cover, Ungask.	1	47.00	0.00	0.00	335.4354
Ladder Well (36-in. Diam.)/Sliding Cover, Ungasketed	1	78.00	0.00	0.00	542.4081
Roof Leg or Hanger Well/Adjustable	6	7.90	0.00	0.00	398.2901
Sample Pipe or Well (24-in. Diam.)/Silt Fabric Seal 10% Open	1	12.00	0.00	0.00	85.6431
Stub Drain (1-in. Diameter)	1	1.20	0.00	0.00	8.5543
Vacuum Breaker (10-in. Diam.)/Weighted Mech. Actuation, Gask.	1	6.20	1.20	0.94	44.2489

**TANKS 4.0.9d**  
**Emissions Report - Detail Format**  
**Individual Tank Emission Totals**

**Emissions Report for: Annual**

**Med Bow F&P Gasoline Off-Spec Tank - Internal Floating Roof Tank**  
**Medicine Bow, Wyoming**

Components	Losses(lbs)				Total Emissions
	Rim Seal Loss	Withdrawl Loss	Deck Fitting Loss	Deck Seam Loss	
Gasoline (RVP 13.5)	77.61	0.12	326.81	4.55	409.10
1,2,4-Trimethylbenzene	0.01	0.00	0.02	0.00	0.03
Benzene	0.27	0.00	1.15	0.02	1.44
Cyclohexane	0.04	0.00	0.16	0.00	0.20
Ethylbenzene	0.02	0.00	0.07	0.00	0.09
Hexane (-n)	0.26	0.00	1.08	0.02	1.36
Isooctane	0.00	0.00	0.00	0.00	0.00
Isopropyl benzene	0.00	0.00	0.01	0.00	0.01
Toluene	0.28	0.01	1.17	0.02	1.47
Unidentified Components	76.67	0.09	322.85	4.49	404.11
Xylene (-m)	0.07	0.01	0.29	0.00	0.38
Gasoline (RVP 15.0)	43.05	0.06	181.26	2.52	226.89
1,2,4-Trimethylbenzene	0.00	0.00	0.01	0.00	0.01
Benzene	0.14	0.00	0.57	0.01	0.72
Cyclohexane	0.02	0.00	0.08	0.00	0.10
Ethylbenzene	0.01	0.00	0.04	0.00	0.04
Hexane (-n)	0.13	0.00	0.54	0.01	0.68
Isooctane	0.00	0.00	0.00	0.00	0.00
Isopropyl benzene	0.00	0.00	0.01	0.00	0.01
Toluene	0.14	0.00	0.58	0.01	0.73
Unidentified Components	42.58	0.05	179.28	2.50	224.40
Xylene (-m)	0.03	0.00	0.15	0.00	0.19
Gasoline (RVP 11.5)	69.07	0.12	290.84	4.05	364.09
1,2,4-Trimethylbenzene	0.01	0.00	0.02	0.00	0.03

DEQ 000308

Benzene	0.29	0.00	1.21	0.02	1.52
Cyclohexane	0.04	0.00	0.17	0.00	0.21
Ethylbenzene	0.02	0.00	0.08	0.00	0.10
Hexane (-n)	0.27	0.00	1.14	0.02	1.42
Isocane	0.00	0.00	0.00	0.00	0.00
Isopropyl benzene	0.00	0.00	0.01	0.00	0.02
Toluene	0.30	0.01	1.25	0.02	1.57
Unidentified Components	66.08	0.09	286.65	3.99	356.81
Xylene (-m)	0.08	0.01	0.32	0.00	0.40
Gasoline (RVP 9)	92.44	0.19	389.22	5.42	487.26
1,2,4-Trimethylbenzene	0.01	0.00	0.05	0.00	0.07
Benzene	0.53	0.00	2.25	0.03	2.82
Cyclohexane	0.07	0.00	0.31	0.00	0.39
Ethylbenzene	0.04	0.00	0.15	0.00	0.19
Hexane (-n)	0.48	0.00	2.08	0.03	2.61
Isocane	0.00	0.01	0.00	0.00	0.01
Isopropyl benzene	0.01	0.00	0.02	0.00	0.03
Toluene	0.57	0.01	2.39	0.03	3.00
Unidentified Components	90.57	0.14	381.34	5.31	477.36
Xylene (-m)	0.15	0.01	0.63	0.01	0.80
Gasoline (RVP 7.8)	91.37	0.19	384.71	5.36	481.62
1,2,4-Trimethylbenzene	0.02	0.00	0.06	0.00	0.08
Benzene	0.65	0.00	2.72	0.04	3.41
Cyclohexane	0.09	0.00	0.38	0.01	0.47
Ethylbenzene	0.05	0.00	0.19	0.00	0.24
Hexane (-n)	0.59	0.00	2.49	0.03	3.12
Isocane	0.00	0.01	0.00	0.00	0.01
Isopropyl benzene	0.01	0.00	0.03	0.00	0.04
Toluene	0.70	0.01	2.96	0.04	3.72
Unidentified Components	89.08	0.14	375.07	5.22	469.51
Xylene (-m)	0.19	0.01	0.80	0.01	1.02
Gasoline (RVP 10)	39.10	0.06	139.39	1.94	174.49
1,2,4-Trimethylbenzene	0.00	0.00	0.01	0.00	0.02
Benzene	0.17	0.00	0.71	0.01	0.89
Cyclohexane	0.02	0.00	0.10	0.00	0.12
Ethylbenzene	0.01	0.00	0.05	0.00	0.06





**TANKS 4.0.9d**  
**Emissions Report - Detail Format**  
**Tank Identification and Physical Characteristics**

**Identification**

User Identification: Med Bow F&P MeOH Off-Spec Tk  
 City: Medicine Bow  
 State: Wyoming  
 Company: Medicine Bow Fuel & Power LLC  
 Type of Tank: Internal Floating Roof Tank  
 Description: Methanol Off-Spec Tank

**Tank Dimensions**

Diameter (ft): 8.50  
 Volume (gallons): 5,000.00  
 Turnovers: 6.00  
 Self Supp. Roof? (y/n): N  
 No. of Columns: 1.00  
 Eff. Col. Diam. (ft): 1.00

**Paint Characteristics**

Internal Shell Condition: Light Rust  
 Shell Color/Shade: White/White  
 Shell Condition: Good  
 Roof Color/Shade: White/White  
 Roof Condition: Good

**Rim-Seal System**

Primary Seal: Vapor-mounted  
 Secondary Seal: None

**Deck Characteristics**

Deck Fitting Category: Typical  
 Deck Type: Bolted  
 Construction: Panel  
 Deck Seam: Panel: 5 x 7.5 Ft  
 Deck Seam Len. (ft): 18.73

**Deck Fitting/Status**

**Quantity**

Access Hatch (24-in. Diam.)/Unbolted Cover, Ungasketed	1
Automatic Gauge Float Well/Unbolted Cover, Ungasketed	1
Column Well (24-in. Diam.)/Built-Up Col.-Sliding Cover, Ungask.	1
Ladder Well (36-in. Diam.)/Sliding Cover, Ungasketed	1
Roof Leg or Hanger Well/Adjustable	6
Sample Pipe or Well (24-in. Diam.)/Silt Fabric Seal 10% Open	1
Stub Drain (1-in. Diameter)/Silt Fabric Seal 10% Open	1

Vacuum Breaker (10-in. Diam.)/Weighted Mech. Actuation, Gask.

1

Meteorological Data used in Emissions Calculations: Cheyenne, Wyoming (Avg Atmospheric Pressure = 11.76 psia)

**TANKS 4.0.9d**  
**Emissions Report - Detail Format**  
**Liquid Contents of Storage Tank**

**Med Bow F&P MeOH Off-Spec Tk - Internal Floating Roof Tank**  
**Medicine Bow, Wyoming**

Mixture/Component	Month	Daily Liquid Surf. Temperature (deg F)			Liquid Bulk Temp (deg F)	Vapor Pressure (psia)			Vapor Mol. Weight	Liquid Mass Fract.	Vapor Mass Fract.	Mol. Weight	Basis for Vapor Pressure Calculations
		Avg.	Min.	Max.		Avg.	Min.	Max.					
Methyl alcohol	All	47.49	41.37	53.62	45.62	0.9814	N/A	N/A	32.0400			32.04	Option 2: A=7.897, B=1474.08, C=229.13

## TANKS 4.0.9d Emissions Report - Detail Format Detail Calculations (AP-42)

### Med Bow F&P MeOH Off-Spec Tk - Internal Floating Roof Tank Medicine Bow, Wyoming

Annual Emission Calculations

Rim Seal Losses (lb):	38.9014
Seal Factor A (lb-mole/ft-yr):	6.7000
Seal Factor B (lb-mole/ft-yr (mph) <sup>n</sup> ):	0.2000
Value of Vapor Pressure Function:	0.0213
Vapor Pressure at Daily Average Liquid Surface Temperature (psia):	0.9814
Tank Diameter (ft):	8.5000
Vapor Molecular Weight (lb/lb-mole):	32.0400
Product Factor:	1.0000
Withdrawal Losses (lb):	0.8808
Number of Columns:	1.0000
Effective Column Diameter (ft):	1.0000
Annual Net Throughput (gal/yr):	30,000.0000
Shell Coefficient Factor (bb/1000 sqft):	0.0015
Average Organic Liquid Density (lb/gal):	6.6300
Tank Diameter (ft):	8.5000
Deck Filling Losses (lb):	163.8025
Value of Vapor Pressure Function:	0.0213
Vapor Molecular Weight (lb/lb-mole):	32.0400
Product Factor:	1.0000
Tot. Roof Filling Loss Fact.(lb-mole/yr):	239.8000
Deck Seam Losses (lb):	2.2801
Deck Seam Length (ft):	18.7258
Deck Seam Loss per Unit Length Factor (lb-mole/ft-yr):	0.1400
Deck Seam Length Factor(ft/sqft):	0.3300
Tank Diameter (ft):	8.5000
Vapor Molecular Weight (lb/lb-mole):	32.0400
Product Factor:	1.0000

Total Losses (lb): 206.8648

Roof Filling/Status	Quantity	Roof Filling Loss Factors		m	Losses(lb)
		KFa(lb-mole/yr)	KFb(lb-mole/(yr mph <sup>n</sup> ))		
Access Hatch (24-in. Diam.)/Unbolted Cover, Ungasketed	1	36.00	5.90	1.20	24.5909
Automatic Gauge Float Well/Unbolted Cover, Ungasketed	1	14.00	5.40	1.10	9.5631
Column Well (24-in. Diam.)/Built-Up Col.-Sliding Cover, Ungask.	1	47.00	0.00	0.00	32.1047
Ladder Well (36-in. Diam.)/Sliding Cover, Ungasketed	1	76.00	0.00	0.00	51.9141
Roof Leg or Hanger Well/Adjustable	6	7.90	0.00	0.00	32.3780
Sample Pips or Well (24-in. Diam.)/Sill Fabric Seal 10% Open	1	12.00	0.00	0.00	8.1970
Stub Drain (1-in. Diameter)	1	1.20	0.00	0.00	0.8197
Vacuum Breaker (10-in. Diam.)/Weighted Mech. Actuation, Gask.	1	6.20	1.20	0.94	4.2351

**TANKS 4.0.9d**  
**Emissions Report - Detail Format**  
**Individual Tank Emission Totals**

**Emissions Report for: Annual**

**Med Bow F&P MeOH Off-Spec Tk - Internal Floating Roof Tank**  
**Medicine Bow, Wyoming**

Components	Losses(lbs)				Total Emissions
	Rim Seal Loss	Withdrawl Loss	Deck Fitting Loss	Deck Seam Loss	
Methyl alcohol	38.90	0.88	163.80	2.28	205.86

### TANKS 4.0.9d Emissions Report - Detail Format Tank Identification and Physical Characteristics

**Identification**

User Identification: Med Bow F&P Slop Tank  
 City: Medicine Bow  
 State: Wyoming  
 Company: Medicine Bow Fuel & Power LLC  
 Type of Tank: Internal Floating Roof Tank  
 Description: Slops Tank

**Tank Dimensions**

Diameter (ft): 15.00  
 Volume (gallons): 7,000.00  
 Turnovers: 6.00  
 Self Supp. Roof? (y/n): N  
 No. of Columns: 1.00  
 Eff. Col. Diam. (ft): 1.00

**Paint Characteristics**

Internal Shell Condition: Light Rust  
 Shell Color/Shade: White/White  
 Shell Condition: Good  
 Roof Color/Shade: White/White  
 Roof Condition: Good

**Rim-Seal System**

Primary Seal: Vapor-mounted  
 Secondary Seal: None

**Deck Characteristics**

Deck Fitting Category: Typical  
 Deck Type: Bolted  
 Construction: Panel  
 Deck Seam: Panel: 5 x 7.5 Ft  
 Deck Seam Len. (ft): 58.32

**Deck Fitting/Status**

**Quantity**

Access Hatch (24-in. Diam./Unbolted Cover, Ungasketed	1
Automatic Gauge Float Well/Unbolted Cover, Ungasketed	1
Column Well (24-in. Diam./Built-Up Col.-Sliding Cover, Ungask.	1
Ladder Well (36-in. Diam./Sliding Cover, Ungasketed	1
Roof Leg or Hanger Well/Adjustable	7
Sample Pipe or Well (24-in. Diam./Slit Fabric Seal 10% Open	1
Stub Drain (1-in. Diameter)/Slit Fabric Seal 10% Open	2

Vacuum Breaker (10-in. Diam.)/Weighted Mech. Actuation, Gask.

1

Meteorological Data used in Emissions Calculations: Cheyenne, Wyoming (Avg Atmospheric Pressure = 11.76 psia)

### TANKS 4.0.9d Emissions Report - Detail Format Liquid Contents of Storage Tank

**Med Bow F&P Slop Tank - Internal Floating Roof Tank  
Medicine Bow, Wyoming**

Mixture/Component	Month	Daily Liquid Surf. Temperature (deg F)			Liquid Bulk Temp (deg F)	Vapor Pressure (psia)			Vapor Mol. Weight	Liquid Mass Fract.	Vapor Mass Fract.	Mol. Weight	Basis for Vapor Pressure Calculations
		Avg.	Min.	Max.		Avg.	Min.	Max.					
Jet naphtha (JP-4)	All	47.49	41.37	53.62	45.62	0.9498	N/A	N/A	80.0000			120.00	Option 1: VP40 = .8 VP50 = 1
Benzene						0.8169	N/A	N/A	78.1100	0.0060	0.0077	78.11	Option 2: A=6.905, B=1211.033, C=220.79
Cyclohexane						0.8545	N/A	N/A	84.1600	0.0120	0.0162	84.16	Option 2: A=6.841, B=1201.53, C=222.55
Ethylbenzene						0.8693	N/A	N/A	106.1700	0.0050	0.0005	106.17	Option 2: A=6.975, B=1424.255, C=219.21
Hexane (n)						1.3885	N/A	N/A	86.1700	0.0160	0.0324	86.17	Option 2: A=6.876, B=1171.17, C=224.41
Isopropyl benzene						0.0297	N/A	N/A	120.2000	0.0020	0.0001	120.20	Option 2: A=6.9366, B=1460.793, C=207.78
Toluene						0.2210	N/A	N/A	92.1300	0.0200	0.0070	92.13	Option 2: A=6.954, B=1344.8, C=219.48
Unidentified Components						1.0005	N/A	N/A	79.6097	0.9160	0.9338	123.26	
Xylene (m)						0.0574	N/A	N/A	106.1700	0.0250	0.0023	106.17	Option 2: A=7.009, B=1462.266, C=215.11



## TANKS 4.0.9d Emissions Report - Detail Format Detail Calculations (AP-42)

### Med Bow F&P Slop Tank - Internal Floating Roof Tank Medicine Bow, Wyoming

Annual Emission Calculations

Rim Seal Losses (lb):	189.2578
Seal Factor A (lb-mole/ft-yr):	6.7000
Seal Factor B (lb-mole/ft-yr (mph <sup>4</sup> n)):	0.2000
Value of Vapor Pressure Function:	0.0211
Vapor Pressure at Daily Average Liquid Surface Temperature (psia):	0.9498
Tank Diameter (ft):	15.0000
Vapor Molecular Weight (lb/lb-mole):	80.0000
Product Factor:	1.0000
Withdrawal Losses (lb):	0.6498
Number of Columns:	1.0000
Effective Column Diameter (ft):	1.0000
Annual Net Throughput (gal/yr.):	42,000.0000
Shell Clingage Factor (bb/1000 sqft):	0.0015
Average Organic Liquid Density (lb/gal):	6.4000
Tank Diameter (ft):	15.0000
Deck Fitting Losses (lb):	418.1888
Value of Vapor Pressure Function:	0.0211
Vapor Molecular Weight (lb/lb-mole):	80.0000
Product Factor:	1.0000
Tot. Roof Fitting Loss Fact.(lb-mole/yr):	248.9000
Deck Seam Losses (lb):	17.5068
Deck Seam Length (ft):	68.3158
Deck Seam Loss per Unit Length Factor (lb-mole/ft-yr):	0.1400
Deck Seam Length Factor (ft/sqft):	0.3300
Tank Diameter (ft):	15.0000
Vapor Molecular Weight (lb/lb-mole):	80.0000
Product Factor:	1.0000
<b>Total Losses (lb):</b>	<b>606.5953</b>

Roof Fitting/Status	Quantity	Roof Fitting Loss Factors		m	Losses(lb)
		KFa(lb-mole/yr)	KFb(lb-mole/(yr mph <sup>4</sup> n))		
Access Hatch (24-in. Diam./Unbolted Cover, Ungasketed)	1	36.00	5.80	1.20	60.8297
Automatic Gauge Float Well/Unbolted Cover, Ungasketed	1	14.00	5.40	1.10	23.5782
Column Well (24-in. Diam./Built-Up Col.-Sliding Cover, Ungasketed)	1	47.00	0.00	0.00	78.1554
Ladder Well (38-in. Diam./Sliding Cover, Ungasketed)	1	76.00	0.00	0.00	127.9360
Roof Leg or Hanger Well/Adjustable	7	7.90	0.00	0.00	93.1339
Sample Pipe or Well (24-in. Diam./Sill Fabric Seal 10% Open)	1	12.00	0.00	0.00	20.2098
Stub Drain (1-in. Diameter)	2	1.20	0.00	0.00	4.0420
Vacuum Breaker (10-in. Diam./Weighted Mech. Actuation, Gasketed)	1	0.20	1.20	0.84	10.4418

**TANKS 4.0.9d**  
**Emissions Report - Detail Format**  
**Individual Tank Emission Totals**

**Emissions Report for: Annual**

**Med Bow F&P Slop Tank - Internal Floating Roof Tank**  
**Medicine Bow, Wyoming**

Components	Losses(lbs)				Total Emissions
	Rim Seal Loss	Withdrawl Loss	Deck Fitting Loss	Deck Seam Loss	
Jet naphtha (JP-4)	169.26	0.64	419.19	17.51	606.60
Hexane (-n)	5.49	0.01	13.59	0.57	19.65
Benzene	1.31	0.00	3.24	0.14	4.69
Toluene	1.18	0.01	2.93	0.12	4.24
Ethylbenzene	0.09	0.00	0.23	0.01	0.33
Xylene (-m)	0.38	0.02	0.95	0.04	1.39
Isopropyl benzene	0.02	0.00	0.04	0.00	0.06
Cyclohexane	2.74	0.01	6.79	0.28	9.82
Unidentified Components	158.05	0.59	391.42	16.35	566.40

**Appendix C**  
**Manufacturer Specifications**

**PKRW**

**ESTIMATED PERFORMANCE PG7121**

Load Condition		BASE	BASE	50%	BASE	50%	BASE	50%
Exhaust Pressure Loss	in H2O	15.0	15.0	15.0	15.0	15.0	15.0	15.0
Ambient Temperature	deg F	85.	85.	85.	45.	45.	0.	0.
Ambient Relative Humidity	%	16.0	16.0	16.0	80.0	80.0	80.0	80.0
Fuel Type		Methane	Methane	Methane	Methane	Methane	Methane	Methane
Fuel LHV	BTU/lb	21,515	21,515	21,515	21,515	21,515	21,515	21,515
Fuel Temperature	deg F	80	80	80	80	80	80	80

**EMISSIONS**

		BASE	BASE	50%	BASE	50%	BASE	50%
NOx	ppmvd @ 15% O2	154.	25.	25.	25.	25.	25.	25.
NOx AS NO2	lb/hr	389.	70.	41.	78.	45.	80.	46.
CO	ppmvd	10.	25.	*****	25.	*****	25.	*****
CO	lb/hr	16.	39.	*****	42.	*****	47.	*****
UHC	ppmvw	7.	7.	-999.	7.	-999.	7.	-999.
UHC	lb/hr	7.	7.	804.	8.	859.	8.	919.
Particulates	lb/hr	5	5	5	5	5	5	5

(PM10 Front-half Filterable Only)

\*\*\* See Combustion For Emissions

**EXHAUST ANALYSIS % VOL.**

Argon	0.90	0.87	0.89	0.85	0.89	0.87	0.91
Nitrogen	75.07	72.36	74.29	72.29	74.26	73.42	75.11
Oxygen	14.04	12.89	15.19	12.76	15.14	13.47	15.53
Carbon Dioxide	3.08	3.29	2.40	3.35	2.42	3.14	2.34
Water	6.92	10.60	7.23	10.75	7.29	9.10	6.12

**SITE CONDITIONS**

Elevation	ft	7355.0
Site Pressure	psia	11.2
Inlet Loss	in H2O	3.50
Exhaust Loss	in H2O	15.00 @ ISO Conditions
Application		Air-Cooled Generator
Power Factor (lag)		0.8
Combustion System		Quiet Combustor

Emission information based on GE recommended measurement methods. NOx emissions are corrected to 15% O2 without heat rate correction and are not corrected to ISO reference condition per 40CFR 60.335(a)(1)(i). NOx levels shown will be controlled by algorithms within the SPEEDTRONIC control system.

This document and its contents have been prepared by GE and provided to the recipient for the sole purpose of evaluating the use of GE products in a potential power generation project. Disclosure of this information to any third party, other than a party assisting the recipient in such evaluation, is strictly forbidden. The data is of estimate quality only. Specific, reliable

**MEDICINE BOW - NITROGEN INJECTION WITH AIR EXTRACTION**

**ESTIMATED PERFORMANCE PG7121 - IGCC. PRELIMINARY. FOR STUDY PURPOSES ONLY**

Load Condition		BASE	BASE	BASE
Inlet Loss	in H2O	3.5	3.5	3.5
Exhaust Pressure Loss	in H2O	14.0	14.0	14.0
Ambient Temperature	deg F	45.	-12.	85.
Ambient Relative Humidity	%	60.0	80.0	18.0

**EMISSIONS**

NOx	ppmvd @ 15% O2	25.	25.	25.
-----	----------------	-----	-----	-----

LHV	BTU/lb	16399.6	16399.6	16399.6
Flow Rate	lb/h	44,450. ✓	47,910.	40,240.
Pressure	psia	335.	335.	335.
Temperature	°F	300.	300.	300.

**EXHAUST ANALYSIS % VOL.**

Argon	1.03	1.03	1.03
Nitrogen	76.82	77.34	76.71
Oxygen	12.22	12.08	12.37
Carbon Dioxide	3.23	3.32	3.17
Water	6.71	6.23	6.73

**SITE CONDITIONS**

Elevation	ft	7354.9
Site Pressure	psia	11.2
Exhaust Loss	in H2O	14.00 @ ISO Conditions
Application		Air-Cooled Generator
Power Factor (lag)		0.8
Combustion System		IGCC Combustor

**MEDICINE BOW - STEAM INJECTION****ESTIMATED PERFORMANCE PG7121 - IGCC, PRELIMINARY, FOR STUDY PURPOSES ONLY**

Load Condition		BASE	BASE	BASE
Inlet Loss	in H2O	3.5	3.5	3.5
Exhaust Pressure Loss	in H2O	14.0	14.0	14.0
Ambient Temperature	deg F	45.	-12.	85.
Ambient Relative Humidity	%	60.0	80.0	18.0
Output	kW	69,500.	74,300.	61,750.
Heat Rate (LHV)	BTU/kWh	10,340.	10,440.	10,550.
Heat Cons. (LHV)	MMBTU/hr	718.4	775.5	651.7
Exhaust Flow	x10 <sup>3</sup> lb/hr	1919.	2023.	1771.
Exhaust Temperature	deg F	975.	958.	1001.

**EMISSIONS**

NOx	ppmvd @ 15% O2	25.	25.	25.
-----	----------------	-----	-----	-----

**PRIMARY FUEL**

Compositions:	%Vol			
CH <sub>4</sub>		59.87	59.87	59.87
H <sub>2</sub>		16.40	16.40	16.40
CH <sub>3</sub> OH		0.50	0.50	0.50
C <sub>2</sub> H <sub>6</sub>		1.76	1.76	1.76
C <sub>3</sub> H <sub>8</sub>		2.81	2.81	2.81
C <sub>4</sub> H <sub>10</sub>		5.20	5.20	5.20
C <sub>5</sub> H <sub>12</sub>		0.11	0.11	0.11
Ar		6.21	6.21	6.21
H <sub>2</sub> O		0.01	0.01	0.01
N <sub>2</sub>		4.49	4.49	4.49
CO		1.08	1.08	1.08
CO <sub>2</sub>		1.56	1.56	1.56
LHV	BTU/lb	16399.6	16399.6	16399.6
Flow Rate	lb/h	43,800.	47,290.	39,740.
Pressure	psia	335.	335.	335.
Temperature	°F	300.	300.	300.

**HEAD-END DILUENT INJECTION**

Compositions:	%Vol			
H <sub>2</sub> O		100.00	100.00	100.00
Flow Rate	lb/h	68,510.	75,650.	62,260.
Pressure	psia	300.	300.	300.
Temperature	°F	500.	500.	500.

**EXHAUST ANALYSIS % VOL**

Argon		1.04	1.04	1.03
Nitrogen		70.74	70.98	70.73
Oxygen		12.98	12.89	13.08
Carbon Dioxide		3.15	3.23	3.09
Water		12.10	11.86	12.07

**SITE CONDITIONS**

Elevation	ft	7354.9
Site Pressure	psia	11.2
Exhaust Loss	in H2O	14.00 @ ISO Conditions
Application		Air-Cooled Generator
Power Factor (lag)		0.8
Combustion System		IGCC Combustor

Emission information based on GE recommended measurement methods. NOx emissions are corrected to 15% O2 without heat rate correction and are not corrected to ISO reference condition per 40CFR 60.335(a)(1)(i). NOx levels shown will be controlled by algorithms within the SPEDTRONIC control system.

IPS- Version Code - 3.7.1/145A0/3.7.1/IG7121-04A-0403  
501543188 11/13/2007 13:47 MedicineBow\_7EA\_Steam.dat

*General Electric Proprietary Information*

DEQ 000324

**Appendix D**  
**Major Equipment List and SCCs**

## IGL Plant Source Classification Codes

<b>Emission Unit</b>	<b>SCC Code</b>
Auxiliary Boiler	10200602
Black-Start Generators (3)	20100201
Catalyst Regenerator	30600106
CO2 Vent Stack	N/A
Coal Storage	30501009
Firewater Pump	20200102
Flares	30490024
Fugitives	30600811
Gasifier Preheaters (5)	30600105
Gasoline Storage Tanks	2501000120
HGT Reactor Charge Heater	30600106
Methanol Storage Tanks	2510000260
Reactivation Heater	30600106
Turbine and HRSG Trains (3)	20100301



IGL Plant Equipment List

Equipment Type	Equipment Name	Equipment Tag	No. of Identical Items
Centrifugal pump	PROCESS CONDENSATE PUMP	P-13001A	1
Centrifugal pump	PROCESS CONDENSATE PUMP SPARE	P-13001B	1
Centrifugal pump	SWS BOTTOMS PUMP	P-13002A	1
Centrifugal pump	SWS BOTTOMS PUMP SPARE	P-13002B	1
Centrifugal pump	AMMONIA STRIPPER BOTTOMS PUMP	P-13004A	1
Centrifugal pump	AMMONIA STRIPPER BOTTOMS PUMP SPARE	P-13004B	1
Centrifugal pump	SOUR KO DRUM PUMP	P-13005A	1
Centrifugal pump	SOUR KO DRUM PUMP SPARE	P-13005B	1
Centrifugal pump	SOUR SHIFT PC PUMP	P-13007A	1
Centrifugal pump	SOUR SHIFT PC PUMP SPARE	P-13007B	1
Aircooler	COS HYDROLYSIS RXTR EFFLUENT	AC-13001	1
Aircooler	SWS PUMPAROUND CLR	AC-13002	1
Aircooler	SOUR GAS COOLER	AC-13003	1
Aircooler	BLOWDOWN WATER COOLER	AC-13004	1
Aircooler	SOUR SHIFT REACTOR EFFLUENT CONDENSER	AC-13006	1
Shell and tube	LP STEAM GENERATOR	E-13002	1
Shell and tube	COS HYDROLYSIS PREHEATER	E-13003	1
Shell and tube	LP BFW PREHEATER	E-13004	1
Shell and tube	HG GUARD BED PREHEATER	E-13005	1
Shell and tube	SWS REBOILER	E-13006	1
Shell and tube	AMMONIA STRIPPER REBOILER	E-13007	1
Shell and tube	SOUR SHIFT LP STEAM GEN	E-13008	1
Shell and tube	SOUR SHIFT FEED/EFFLUENT	E-13009	1
Shell and tube	SOUR SHIFT MP STEAM GEN	E-13010	1
Shell and tube	AMMONIA STRIP FEED PRE	E-13011	1
Shell and tube	MP STEAM GENERATOR	E-13011	1
Shell and tube	1ST MP BFW PREHEATER	E-13012	1
Shell and tube	1ST MP BFW PREHEATER	E-13013	1
Shell and tube	VLP STEAM GEN	E-13014	1
Shell and tube	SWS FEED PREHEATER	E-13015	1
Shell and tube	SHIFTED HG GB PREHTR	E-13016	1
Tower	SOUR WATER STRIPPER	T-13001	1
Tower	AMMONIA STRIPPER	T-13002	1
Reactor	COS HYDROLYSIS REACTOR	R-13001	1
Reactor	CO SHIFT REACTOR	R-13002	3
KO Drum	HOT SYNGAS KO DRUM	V-13001	1
KO Drum	COLD SYNGAS KO DRUM	V-13002	1
KO Drum	SOUR GAS KO DRUM	V-13003	1
Tank	CAUSTIC INJECTION DRUM	V-13004	1
KO Drum	SOUR SHIFT KO DRUM	V-13005	1
KO Drum	COLD SHIFTED KO DRUM	V-13006	1
Aircooler	No 1 Vac Flash Ohead Con	03E-303	1
Aircooler	No 2 Vac Flash Ohead Con	03E-303	1
Aircooler	HP Flash Trim Air Cooler	03E-302	1
Aircooler	No 1 Vac Flash Ohead Con	03E-203	1
Aircooler	No 2 Vac Flash Ohead Con	03E-203	1
Aircooler	HP Flash Trim Air Cooler	03E-202	1
Aircooler	No 1 Vac Flash Ohead Con	03E-103	1

## IGL Plant Equipment List

Aircooler	No 2 Vac Flash Ohead Con	03E-103	1
Aircooler	HP Flash Trim Air Cooler	03E-102	1
Aircooler	Quench Water Startup Clr	03E-005	1
Aircooler	HP Flash Trim Air Cooler	03E-402	1
Aircooler	No 1 Vac Flash Ohead Con	03E-403	1
Aircooler	No 2 Vac Flash Ohead Con	03E-403	1
Aircooler	HP Flash Trim Air Cooler	03E-502	1
Aircooler	No 1 Vac Flash Ohead Con	03E-503	1
Aircooler	No 2 Vac Flash Ohead Con	03E-503	1
Centrifugal pump	Injector Coolant Pump	02-P001A/B/C	3
Centrifugal pump	Lockhopper Circ. Pump	02-P102A/B	10
Centrifugal pump	Slag Sump Pump	02P-103A/B	10
Centrifugal pump	Preheat Water Pump	02-P-104A	10
Centrifugal pump	Vac. Flash Cond. Pump	03P-104A/B	10
Centrifugal pump	Slurry Transfer Pump	01P-103	1
Centrifugal pump	Slurry Transfer Pump	01P-203	1
Centrifugal pump	Slurry Transfer Pump	01P-303	1
Centrifugal pump	Scrubber Feed Pump	03P-002	6
Centrifugal pump	Settler Bottoms Pump	03-P005	4
Centrifugal pump	Grey Water Discharge Pump	03P-006	4
Centrifugal pump	Filter Feed Pump	03P-008A/B/C	3
Centrifugal pump	Grinding Water Pumps	03P-009A/B/C	3
Centrifugal pump	Quench Water Pump	03P-101A/B	10
Centrifugal pump	Vac Flash Bottoms Pump	03P-103A/B	10
Centrifugal pump	Grinding Sump Pump	01P-005A/B	2
Centrifugal pump	Fines Area Sump Pump	03P-007A/B	2
Ejector	Startup aspirator	02X-105	5
Filter	Quench water Strainer	02F-102	10
GE Quench Gasifier	Quench Gasifier	02R-101	1
GE Quench Gasifier	Quench Gasifier	02R-101	1
GE Quench Gasifier	Quench Gasifier	02R-101	1
GE Quench Gasifier	Quench Gasifier	02R-101	1
GE Quench Gasifier	Quench Gasifier	02R-101	1
KO Drum	Gasifier Seal Pot	02V-102	5
KO Drum	Aspirator Separator	02V-103	5
KO Drum	Injector Coolant Gas Sepr	02V-105	5
KO Drum	HP Flash Drum	03V-103	5
KO Drum	LP Flash Drum	03V-105	5
KO Drum	Vacuum Flash Drum No 1	03V-106	5
KO Drum	Vacuum Flash Drum No2	03V-108	5
KO Drum	HP Flash OH Drum	03V-104	5
KO Drum	No 1 Vac Flash OH Drum	03V-107	5
KO Drum	No 1 Vac Flash OH Drum	03V-109	5
KO Drum	Lockhopper	02V-106	5
KO Drum	Lockhopper Flush Drum	02V-107	5
Other	Slag Crusher	02X-103	5
Shell and tube	HP Flash OH Condenser	03E-101	5
Shell and tube	HP Flash OH Condenser	03E-201	5
Shell and tube	HP Flash OH Condenser	03E-301	5
Shell and tube	HP Flash OH Condenser	03E-401	5
Shell and tube	HP Flash OH Condenser	03E-501	5

## IGL Plant Equipment List

Tank	Grey Water Tank	03T-002	1
Tank	Slurry Additive Tank	03T-003	1
Tank	Mill Discharge tank	01T-104	3
Tank	Slurry Tank	01T-105	3
Tank	Injector Coolant Tank	02T-001	1
Tank	Settler	03T-001	2
Tank	Filter Feed Tank	03T-004	1
Tank	Filtrate Tank	03T-005	1
Tower	Syngas Scrubber	03V-101	5
	Slurry Additive Tank Agit	01A-001	1
	Grinding Sump Agitator	01A-004	1
	Mill Discharge Tank Agitr	01A-102	3
	Slurry Tank Agitator	01A-103	5
	Grind Mill Disch HVAC Fan	01C-101	3
	Trommel Screen	01F-101	5
	Fluxant feed Conveyor	01L-101	3
	Grinding Sump	01T-106	1
	Fluxant Weigh Feeder	01W-101	3
	Slag Sump Agitator	02A-102	5
	Oxygen Filter	02F-101	10
	Slurry Vibrating Screen	02F-102	3
	Coarse Slag Screen	02F-103	5
	Slag Drag Conveyor	02L-101	5
	Slag Sump	02T-102	5
	Oxygen Silencer	02X-101	5
	Feed Injector	02X-102	10
	Preheat Burner	02X-104	5
	Settler Rake	03A-001	2
	Fines Sump Agitator	03A-002	1
	Filter Feed tank Agitator	03A-003	1
	filtrate Tank Agitator	03A-004	1
	Fines Filter Press	03F-001	3
	Fines Sump	03T-003	1
	Nozzle Scrubber	03X-101	5
	Gasifier Refractory	02R-101-int	5
Filter	Crude Methanol Filter	H-321 A/B	2
Filter	Crude Methanol Filter	H-322 A/B	2
Compressor	Syngas Compressor	J-111	1
Compressor	Loop Circulator	J-121	1
Aircooler	Syngas Comp Spilback	E-211	1
aircooler	Loop condenser No.1	E-221	1
aircooler	Loop condenser No.2	E-222	1
Shell and tube	Syngas purifict preheater	E-111	1
Shell and tube	loop Interchanger no.1	E-121	1
Shell and tube	loop interchanger no.2	E-123	1
Reactor	Syngas purification vessl	D-111	2
Reactor	Methano Synthesis Reactor	D-121	1
Reactor	Methano Synthesis Reactor	D-122	1
KO Drum	Syngas KO Drum	D-311	1
Reactor	PSA Unit - 5 drums total	L-121	5
KO Drum	Methanol Catchpot No.1	D-321	1

IGL Plant Equipment List

KO Drum	Methanol Catchpot No.2	D-322	1
KO Drum	Letdown Vessel	D-323	1
Centrifugal pump	MeOH Charge	P-01 A/B	2
Centrifugal pump	Deethanizer Feed	P-02 A/B	2
Centrifugal pump	MTG Process Water	P-03 A/B	2
Centrifugal pump	Deethanizer Ovhd Cooler	P-04 A/B	2
Centrifugal pump	Stabilizer OVHD	P-05 A/B	2
Centrifugal pump	Lean oil Supply	P-06 A/B	2
Centrifugal pump	Splitter OVHD	P-07 A/B	2
Centrifugal pump	Splitter BTTMS	P-08 A/B	2
Centrifugal pump	Absorber BTTMS	P-09 A/B	2
Centrifugal pump	MeOH Recovery OVHD	P-10 A/B	2
Centrifugal pump	MeOH BTTMS	P-11 A/B	2
Centrifugal pump	HGT Charge	P-351 A/B	2
Centrifugal pump	Stripper OVHD	P-352 A/B	2
Tower	Deethanizer	C-1	1
Furnace	Regeneration Heater	B-1	1
Furnace	Reactivation Heater	B-2	1
Furnace	HGT Reactor Charge	B-351	1
Compressor	MTG Recycle gas	K-1	1
Compressor	Regeneration Air	K-2	1
Compressor	Regeneration Gas	K-3	1
Compressor	HGT Recycle	K-351 A/B	1
Aircooler	MTG Reactor Effluent Coolers	EA-1	1
Aircooler	Regeneration Cooler	EA-2	1
Aircooler	Deethanizer Ovhd Condenser	EA-3	1
Aircooler	Stabilizer OVHD Condenser	EA-4	1
Aircooler	LPG Cooler	EA-5	1
Aircooler	Lean Oil Cooler	EA-6	1
Aircooler	Splitter OVHD Condenser	EA-7	1
Aircooler	Light Gasoline Cooler	EA-8	1
Aircooler	Heavy Gasoline Cooler	EA-9	1
Aircooler	MeOH Recovery Condenser	EA-10	1
Aircooler	LT Separator Feed Cooler	EA-351	1
Aircooler	Stripper OVHD Condenser	EA-352	1
Shell and Tube	MeOH Preheater	E-1	1
Shell and Tube	MeOH Vaporizer	E-2	1
Shell and Tube	MeOH Supper Heater	E-3	1
Shell and Tube	Recycle Gas/Effluent HX	E-4	1
Shell and Tube	HP Steam Generator	E-5	1
Shell and Tube	Regeneration Gas Interchanger	E-6	1
Shell and Tube	Deethanizer Reboiler	E-7	1
Shell and Tube	Deethanizer Feed / Bttms	E-8	1
Shell and Tube	Stabilizer Reboiler	E-9	1
Shell and Tube	Splitter Reboiler	E-10	1
Shell and Tube	HGT Feed/ Stripper BTTMS	E-351	1
Shell and Tube	HGT Feed / reactor Effluent	E-352	1
Shell and Tube	HGT Recycle Gas / HT Separator	E-353	1
Shell and Tube	Cold Stripper Feed / LT Sep Feed	E-354	1
Shell and Tube	Stripper Reboiler	E-355	1
Shell and Tube	Treated Heavy Gasoline Cooler	E-356	1

## IGL Plant Equipment List

KO Drum	MeOH Flash Drum	D-1	1
KO Drum	HP Steam Drum	D-2	1
KO Drum	Product Separator	D-3	1
KO Drum	Deethanizer OH Drum	D-6	1
KO Drum	Stabilizer OH Drum	D-7	1
KO Drum	Splitter OH Drum	D-8	1
KO Drum	Absorber Feed KO Drum	D-9	1
KO Drum	MeOH OVHD Drum	D-11	1
KO Drum	HGT Feed Surge Drum	D-351	1
KO Drum	Low Temp Separator	D-353	1
KO Drum	Stripper OH Drum	D-355	1
Tower	Absoorber	C-4	1
Tower	MeOH Recovery Column	C-5	1
Tower	Product Stripper	C-351	1
Tower	Gasoline Splitter	C-3	
KO Drum	MTG Process Water Flash Drum	D-4	1
KO Drum	Regeneration Gas Separator	D-5	1
KO Drum	Absorber OVHD KO Drum	D-10	1
KO Drum	Height Temp. Separator	D-352	1
KO Drum	HGT Recycle Gas KO Drum	D-354	1
Centrifugal pump	MTG Water Pump		2
Centrifugal pump	Methanol Transfer Pump		2
Centrifugal pump	Gasoline Send-Out Pump		3
Centrifugal pump	Sulfur Send-Out Pump		2
Centrifugal pump	Slops Tank Transfer Pump		1
Centrifugal pump	Acid Gas Wash Drum Pump	P-31001 A/B	2
Centrifugal pump	Contact Cond. Circ. Pump	P-31005 AB	2
Centrifugal pump	Desuperheater Circ. Pump	P-31006	1
Centrifugal pump	Sulfur Degassing Pump	P-31003 A/B	2
Centrifugal pump	Sulfur Transfer Pump	P-31004 A/B	2
Ejector	Sulfur Pit Vent Ejector	EJ-31001	1
Ejector	Degassing Vent Ejector	EJ-31002	1
Fan	Start-Up Blower	BL-31002	1
Furnace	Claus Reaction Furnace	H-31001	1
Aircooler	Waste Steam Condenser	AC-31006	1
Aircooler	Spent Caustic Cooler	AC-31009	1
Aircooler	Contact Cond. H2O Cooler	AC-31014	1
Shell and Tube	No. 1 Condenser	E-31002	1
Shell and Tube	No. 2 Condenser	E-31003	1
Shell and Tube	No. 3 Condenser	E-31004	1
Shell and Tube	No. 4 Condenser	E-31005	1
Shell and Tube	No. 1 Reheater	E-31007	1
Shell and Tube	No. 2 Reheater	E-31008	1
Shell and Tube	No. 3 Reheater	E-31009	1
Shell and Tube	Hydrogen. Effl. Cooler*	E-31012	1
Shell and Tube	Hydrogenator Preheater	E-31013	1
Shell and Tube	Waste Heat Boiler	E-31001	1
Tower	Sulfur Degasser	T-31xxx	1
Tower	Desuperhr/Contact Cond.	T-31003	1
KO Drum	Acid Gas KO Drum	V-31001	1
KO Drum	Steam Drum	V-31003	1

## IGL Plant Equipment List

KO Drum	*Claus Converter	R-31001/2/3	1
KO Drum	S/U Blower KO Drum	V-31xxx	1
Centrifugal pump	HP Lean Solvent Pump	P-21001	4
Centrifugal pump	Reflux Pump	P-21002	4
Centrifugal pump	Loaded Solvent Pump	P-21003	4
Centrifugal pump	Semi-Lean Solvent Pump	P-21004	4
Centrifugal pump	LP Lean Solvent Pump	P-21005	4
Centrifugal pump	Semi-Lean Pump Unshifted	P-21xxx	4
Centrifugal pump	H2S Pump for Unshifted	P-21xxx	4
Centrifugal pump	Hydraulic Turbine 1	P-21xxx	4
Centrifugal pump	Hydraulic Turbine 2	P-21xxx	4
Compressor	Stripping Gas Compressor	K-21001	2
Compressor	H2S Flash Gas Comp. 2	K-21002	2
Compressor	CO2 Recycle Compressor	K-21003	2
Compressor	H2S Flash Gas Comp. 1	K-21xxx	2
Compressor	TG Comp. Stage 1	K-21010	2
Compressor	TG Comp. Stage 2	K-21011	2
Aircooler	H2S Recycle Gas Cooler 2	E-21007	2
Aircooler	H2S Flash Gas Cooler 2	E-21003	2
Aircooler	H2S Recycle Gas Cooler	E-21006	2
Aircooler	Reflux Condenser	E-21005	2
Aircooler	CO2 Recycle Gas Cooler	E-21011	2
Aircooler	H2S Flash Gas Cooler 1	E-21010	2
Aircooler	Shifted Feed Gas Cooler	E-21xxx	2
Aircooler	TG Compressor Cooler 1	E-21xxx	2
Shell and Tube	Feed / Product Exchanger	E-21001	2
Shell and Tube	Lean / Rich Exchanger	E-21002	2
Shell and Tube	Lean Solvent Chiller	E-21008	2
Shell and Tube	Loaded Solvent Chiller	E-21009	2
KO Drum	H2S Rich MP Flash Drum	V-21001	2
KO Drum	Flash Gas KO Drum	V-21002	2
KO Drum	Reflux Drum	V-21003	2
KO Drum	CO2 Recycle Flash Drum	V-21004	2
KO Drum	CO2 MP Flash Drum	V-21005	2
KO Drum	CO2 LP Flash Drum	V-21006	2
KO Drum	H2S Rich LP Flash Drum	V-21xxx	2
Shell and Tube	Stripper Reboiler	E-21004	1
Tower	H2S Absorber Shifted Gas	C-21001	2
Tower	H2S Concentrator	C-21002	2
Tower	H2S Stripper	C-21003	2
Tower	CO2 Absorber Shifted Gas	C-21004	2
Tower	CO2 Absorber Unshifted Gas	C-21005	2
Tower	H2S Absorber Unshifted Gas	C-21006	2
Other	Refrigeration Package A/B	Z-21001AB	2
Tank	Methanol Tanks		2
Tank	Gasoline Product Tanks		8
Tank	MTG Water Tank		1
Tank	Liquid Sulfur Storage Tk.		2
Tank	Slops Tank		1
Tank	Off-spec methanol tank		1
Tank	Off-spec gasoline tank		1

**IGL Plant Equipment List**

Tank	Heavy Gasoline Tank	1
KO Drum	METHANOL LET DOWN DRUM	1
KO Drum	Flare KO Drums	4
Tank	LPG Tanks	2
Flare	Flare Stack	2
Centrifugal pump	MTG Water Pump	2
Centrifugal pump	Methanol Transfer Pump	2
Centrifugal pump	Gasoline Send-Out Pump	3
Centrifugal pump	Sulfur Send-Out Pump	2
Centrifugal pump	Slops Tank Transfer Pump	1
Centrifugal pump	Flare KO Drum Pump	4
	Air Separation Unit	2
	Power Plant	1
	Auxiliary Boiler	1
	Fire Protection	1
	Set Up Transformers	1
	Switchyard	1
	Water Treatment System	1

Along with the equipment listed above, there will be several conveyors that will be used to transfer coal from the mine to the coal storage, and from storage to the plant. There will also be conveyors to move slag from the gasifiers to the slag storage area.

**Appendix E**

**BACT Review of Recent NO<sub>x</sub> Limits for Combined Cycle Combustion Turbines Fueled  
With Other Gaseous Fuels**



**BACT Review of Recent NO<sub>x</sub> Limits for Combined Cycle Combustion Turbines Fueled With Other Gaseous Fuels**

Facility	Fuel	Capacity	NO <sub>x</sub> Emission Limit	Pollution Control Method	Basis	Permit Date (Permit Number)
Bayport Energy Center LP, Bayport Energy Center	Mixture of low-sulfur fuel gas and NG	225 MMBtu/hr	3.5 ppmvd (3-hour), 1.9 ppmvd (annual)	Dry low- NO <sub>x</sub> combustors and low- NO <sub>x</sub> duct burners	BACT-PSD	10/20/2003 (P1031)
Union Carbide Corp., Texas City Operations	Primary fuel gas	14.2 MW	25 ppmvd @ 15% O <sub>2</sub> (each)	Low- NO <sub>x</sub> combustor	Other case-by-case	1/23/2003 (PSD-TX-841)
Tampa Electric Company TECO-Polk Power	Syngas from petcoke and coal	190 MW	15 ppmvd @ 15% O <sub>2</sub> (each)	Combustion improvement, nitrogen diluent injection	Other case-by-case	12/23/2002 (PSD-FL-194)
Exxon Mobil, Exxon Mobil Shute Creek	Proprietary mix of process gas, sales gas, and hydrogen	35.8 MW	8 ppmvd @ 15% O <sub>2</sub> (30-day rolling average)	Proprietary low-BTU fuel and low- NO <sub>x</sub> burners	BACT-PSD	6/19/2002 (MD-771)
Global Energy, Inc., Lima Energy Company	Syngas	170 MW	15 ppmvd @ 15% O <sub>2</sub>	Dilution prior to combustion and dilution injection into combustion zone	BACT-PSD	3/26/2002 (03-13445)
Kentucky Pioneer Energy, LLC, Kentucky Pioneer Energy, LLC - Trapp	Synthesis gas	197 MW	15 ppmvd @ 15% O <sub>2</sub>	Steam injection	BACT-PSD	6/7/2001 (V-00-049)
Borden Chemicals and Plastics Operating, LP (COGEN III Unit)	NG / acetylene	473 MMBtu/hr	62 ppmvd @ 15% O <sub>2</sub>	Steam injection	RACT	5/29/2001 (PSD-LA-539)
Borden Chemicals and Plastics Operating, LP (COGEN II Unit)	NG / acetylene	471 MMBtu/hr	51 ppm @ 15% O <sub>2</sub>	Steam injection	BACT-PSD (prior determination)	5/29/2001 (PSD-LA-535 [M-2])
Valero Refining Co. - Texas City	Refinery fuel gas	Not available	27 ppm @ 15% O <sub>2</sub>	Not available	Other case-by-case	2/23/2000 (PSD-TX-822M2)
Sweeny Cogeneration	Residue gas	121.3 MW (each)	15 ppm @ 15% O <sub>2</sub>	Dry low- NO <sub>x</sub> burners	Other case-by-	9/30/1998

Facility	Fuel	Capacity	NO <sub>x</sub> Emission Limit	Pollution Control Method	Basis	Permit Date (Permit Number)
Limited Partnership			(natural gas only), 25 ppm @ 15% O <sub>2</sub> (natural gas and residue gas)		case	(PSD-TX-857)
Star Enterprise	Syngas or LSDF	90 MW (each)	16 ppm @ 15% O <sub>2</sub>	Nitrogen Injection (firing syngas), steam injection (firing LSDF)	LAER	3/30/1998 (APC-97/0503-CONST)

**Note:**

Information was obtained from the RACT/BACT/LAER Clearinghouse based on process type 15.250 (Large Combustion Turbines [ $>25$  MW], Combined-Cycle & Cogeneration [ $>25$  MW], Other Gaseous Fuel & Gaseous Fuel Mixtures). The search period included the ten-year period from 9/28/1997 to 9/28/2007.

**Acronyms:**

LAER = Lowest achievable emission rate

LSDF = Low-sulfur diesel fuel

MMBtu/hr = Million British thermal units per hour

MW = Megawatt

NG = Natural gas

NO<sub>x</sub> = Nitrogen oxides

O<sub>2</sub> = Oxygen

PSD = Prevention of significant deterioration

RACT = Reasonable available control technology

**Appendix F**  
**Coal Storage BACT Cost Analysis**

SADDLEBACK HILLS MINE SURFACE FACILITY

**Preliminary Cost Estimates**

The following preliminary cost estimates, with an accuracy of  $\pm 20\%$ , are based on three active storage options that were considered:

- Option 1 reflects a 300,000 ton active storage pile with stacking tubes and live reclaim located in a sheltered area located between the high wall and an earthen berm.
- Option 2 reflects a 300,000 ton active storage pile with stacking tubes and live reclaim located in an open area that is un-sheltered from wind erosion.
- Option 3 reflects 300,000 ton totally enclosed slot storage with 100% live storage.

	<u>Option #1</u>	<u>Option #2</u>	<u>Option #3</u>
Ancillary Buildings	\$30,746,100	\$30,742,800	\$30,654,000
Road and Ditches & Civil	\$8,554,700	\$5,096,400	\$5,030,400
Material Handling	\$45,399,200	\$46,360,800	\$43,701,600
Enclosed Slot Storage	\$0	\$0	\$77,814,000
Total	\$84,700,000	\$82,200,000	\$157,200,000
+20%	\$101,640,000	\$98,640,000	\$188,640,000
-20%	\$67,760,000	\$65,760,000	\$125,760,000



ENGINEERS & CONTRACTORS

**ROBERTS & SCHAEFER**

DEQ 00033 *Signature*

**PRELIMINARY EMISSIONS AND BACT ANALYSIS**  
(Pending verification of assumptions, costs, etc.)

**Saddleback Hills Mine Storage System**

**UMS BACT Analysis: In-Pit Tube Stacker vs. Covered Slot Storage**

	Option 1: Covered Slot Storage	Option 2: Tube Stacker in Pit	Option 1 vs. Option 2 Comparison
Capital Cost	\$115,000,000	\$9,000,000	
Mine Life (Years)	20	20	
Discount Rate (annual cost of capital)	8.0%	8.0%	
Net Present Value of Annual O&M Cost	\$0	\$7,363,611	
Levelized Annual Cost	\$5,750,000	\$818,181	
Annual PM-10 Emissions (tpy)	0.0	64.1	
Differential Emissions Control (tpy)			64.1
Differential Technology Cost per Year			\$4,931,819
Incremental Control Cost (per ton PM-10)			\$76,992

**UMS BACT Analysis: In-Pit Tube Stacker vs. Surface Tube Stacker**

	Option 2: Tube Stacker In Pit	Option 3: Tube Stacker Surf.	Option 2 vs. Option 3 Comparison
Capital Cost	\$9,000,000	\$8,000,000	
Mine Life (Years)	20	20	
Discount Rate (annual cost of capital)	8.0%	8.0%	
Net Present Value of Annual O&M Cost	\$7,363,611	\$7,363,611	
Levelized Annual Cost	\$818,181	\$768,181	
Annual PM-10 Emissions (tpy)	64.1	82.2	
Differential Emissions Control (tpy)			18.1
Differential Technology Cost per Year			\$50,000
Incremental Control Cost (per ton PM-10)			\$2,761

Arch Coal Company, Saddleback Hills Mine  
 BACT Option 1 (In-Pit Stacking Tubes) PM-10 Emissions

Emission Source	Type	Description	Control	Additional Information
Dozer Reclaim	Fugitive	Cat D11 Dozer	None	
		Emission Factor	8.0 Lb/Hr	WDEQ 2002 Guidance
		Total Throughput	6,000,000 Tons/Yr	Total Coal Through Storage
		Dozed Throughput	3,000,000 Tons/Yr	Portion to Dead Storage
		Dozer Productivity	1,000 Tons/Hr	Estimate for 300,000 Ton Pile
		Operating Hrs	3,000 Hrs	Productivity/Throughput
		TSP Emissions	12.00 Tons/Yr	$E=(EF \times Op \text{ Hrs})/2000$
		PM-10 Emissions	3.60 Tons/Yr	30% of TSP
Coal Stacker	Fugitive	Coal Dumping to Stockpile	Stacking Tubes	
		Emission Factor	0.017 Lb/Ton	WDEQ Emission Factor
		% Suspended	0.75	WDEQ Emission Factor
		Control Factor	50.00%	Estimated
		Material Dumped	6,000,000 Tons/Yr	Total Coal Through Storage
		TSP Emissions	19.13 Tons/Yr	$E=(EF \times \% \text{ sus} \times MD/2000) \times (1-CF)$
		PM-10 Emissions	5.74 Tons/Yr	30% of TSP
Coal Reclaim	Fugitive	Vibratory & Pile Activator Feeder	Passive Control	
		Emission Factor	0.017 Lb/Ton	WDEQ Emission Factor
		% Suspended	0.75	WDEQ Emission Factor
		Control Factor	100.00%	Estimated
		Material Reclaimed	6,000,000 Tons/Yr	Total Coal Through Storage
		TSP Emissions	0.00 Tons/Yr	$E=(EF \times \% \text{ sus} \times MR/2000) \times (1-CF)$
		PM-10 Emissions	0.00 Tons/Yr	30% of TSP
Coal Stockpile	Fugitive	Wind Erosion on Stockpiles	Water	
		Emission Factor	1.2 Lb/Acre/Hr	WDEQ Emission Factor
		Pile Size	11.0 Acres	Calculated from Pile Size
		Fraction Suspended	0.75	WDEQ Emission Factor
		Hours	8,760 Hours	Total Annual
		Ave. Wind Speed	5.03 meters/Sec	Adjusted for in-pit
		Wet Days	60	Seminole Mine 5-Year Average
		Control Factor	0.00%	
		TSP Emissions	182.40 Tons/Yr	$E=(EF \times AWS \times \% \text{ sus} \times PS \times ((365-WD)/365) \times (1-CF))/2000$
		PM-10 Emissions	54.72 Tons/Yr	
TOTAL PM-10 EMISSIONS			64.1 Tons/Yr	

Arch Coal Company, Saddleback Hills Mine  
 BACT Option 2 (On-Surface Tube Stacker) PM-10 Emissions

Emission Source	Type	Description	Control	Additional Information
Dozer Reclaim	Fugitive	Cat D11 Dozer	None	
		Emission Factor	8.0 Lb/Hr	WDEQ 2002 Guidance
		Total Throughput	6,000,000 Tons/Yr	Total Coal Through Storage
		Dozed Throughput	3,000,000 Tons/Yr	Portion to Dead Storage
		Dozer Productivity	1,000 Tons/Hr	Estimate for 300,000 Ton Pile
		Operating Hrs	3,000 Hrs	Productivity/Throughput
		TSP Emissions	12.00 Tons/Yr	$E=(EF \times Op \text{ Hrs})/2000$
		PM-10 Emissions	3.60 Tons/Yr	30% of TSP
Coal Stacker	Fugitive	Coal Dumping to Stockpile	Stacking Tubes	
		Emission Factor	0.017 Lb/Ton	WDEQ Emission Factor
		% Suspended	0.75	WDEQ Emission Factor
		Control Factor	50.00%	Estimated
		Material Dumped	6,000,000 Tons/Yr	Total Coal Through Storage
		TSP Emissions	19.13 Tons/Yr	$E=(EF \times \% \text{ sus} \times MD/2000) \times (1-CF)$
		PM-10 Emissions	5.74 Tons/Yr	30% of TSP
Coal Reclaim	Fugitive	Vibratory & Pile Activator Feeder	Passive Control	
		Emission Factor	0.017 Lb/Ton	WDEQ Emission Factor
		% Suspended	0.75	WDEQ Emission Factor
		Control Factor	100.00%	Estimated
		Material Reclaimed	15,000,000 Tons/Yr	Total Coal Through Storage
		TSP Emissions	0.00 Tons/Yr	$E=(EF \times \% \text{ sus} \times MR/2000) \times (1-CF)$
		PM-10 Emissions	0.00 Tons/Yr	30% of TSP
Coal Stockpile	Fugitive	Wind Erosion on Stockpiles	Water	
		Emission Factor	1.2 Lb/Acre/Hr	WDEQ Emission Factor
		Pile Size	11.0 Acres	Calculated from Pile Size
		Fraction Suspended	0.75	WDEQ Emission Factor
		Hours	8,760 Hours	Total Annual
		Ave. Wind Speed	6.70 meters/Sec	Avg wind speed at surface
		Wet Days	60	Seminole Mine 5-Year Average
		Control Factor	0.00%	
		TSP Emissions	242.77 Tons/Yr	$E=(EF \times AWS \times \% \text{ sus} \times PS \times ((365-WD)/365) \times (1-CF))/2000$
		PM-10 Emissions	72.83 Tons/Yr	
<b>TOTAL PM-10 EMISSIONS</b>			<b>82.2 Tons/Yr</b>	

**Appendix G**  
**Mercury Removal Costs**

DEQ 000342



**COSTS FOR MERCURY REMOVAL SYSTEM**

Client	DKRW
Service	Mercury Guard Beds
Equipment ID	R-2801 A/B
Capacity, MMscfd (each vessel)	304.00
Flow Rate, Nm <sup>3</sup> /hr (each vessel)	334,927
Hg Inlet Concentration, µg/Nm <sup>3</sup>	91.22
Hg Outlet Concentration, µg/Nm <sup>3</sup>	0.02
Hg Mass Removed, µg/Nm <sup>3</sup>	91.20
Hg Removal Efficiency, %	99.98
Hg Mass Removed, lb/hr (each vessel)	0.067
Hg Mass Removed, ton/yr (each vessel)	0.295
Hg Mass Removed, ton/yr (both vessels)	0.590

<b>Total Capital Cost</b>		<b>Cost in Estimated</b>
<b>Itemized Expenditures</b>		
<b>CAPITAL COSTS:</b>		
Carbon Adsorbent Cost		\$ 135,000
Equipment Installed Cost		\$ 1,000,000
<b>Total Installed Cost (TIC)</b>		<b>\$ 1,135,000</b>
<b>OPERATING COSTS:</b>		
Catalyst Replacement (every 10 years)		\$ 13,500
<b>Annual Operating Costs</b>		<b>\$ 13,500</b>
<b>TOTAL ANNUAL COSTS:</b>		
Capital Recovery Factor (9.1%, 20 yr life)		
Annualized Total Capital Investment	0.1103	x TIC \$ 125,223
<b>Total Annual Costs, \$/yr</b>		<b>\$ 138,723</b>
<b>HG REMOVAL:</b>		
Hg Removed, ton/yr	0.590	
<b>Cost of Hg Removed, \$/ton</b>		<b>\$ 235,164</b>

All costs are based on a mercury guard bed design provided by SME Associates.

**Hg-A****VAPOR PHASE MERCURY FILTRATION**

Prepared for SNC

PROJECT: DKRW Energy CGTL

ITEM: Hg Capture

**SME Associates**

13231 Champion Forest Dr, Suite 201

Houston, Tx. 77069

Phone (281)440-7350

Fax (281)440-7353

This design was prepared 13-Jun-06

Call Daren Scott if questions arise

**DESIGN CONDITIONS**

FLOWRATE:	304	MMSCFD/VESSEL
FLOWRATE:	694,414	#/FT3
FLOWRATE:	334,927.4	NM3/HR
MOLECULAR WEIGHT:	20.805	
OPERATING PRESSURE:	945	PSIA
DESIGN TEMPERATURE:	120	oF
H2O SATURATION TEMP:	120	oF
H2O RELATIVE HUMIDITY:	100	%
COMPRESSIBILITY USED:	0.987	Z
DENSITY:	3.20	#/FT3
VISCOSITY:	0.017	cp
INLET Hg CONTENT:	97	PPB(WT)
" " " :	10.06	PPB(VOL)
" " " :	91,223	NANOGRAMS /NM3 (ng/Nm3)
" " " :	91.22	MICROGRAMS/NM3 (ug/Nm3)
" " " :	0.0912	MILLIGRAMS/NM3 (mg/Nm3)
" " " :	2.412	GRAMS/MMSCF
" " " :	1.617	#/DAY HG
OUTLET Hg CONTENT:	<0.02	MICROGRAMS/NM3 (ug/Nm3)

**DESIGN VARIABLES**

MAXIMUM SUPERFICIAL VELOCITY:	50	FPM
MINIMUM CONTACT TIME:	15	SEC.
EXTRUDATE SIZE:	4	mm
LOADING USED:	20	

**SELECTION**

VESSEL ID; USED:	9.5	FT.
SUPERFICIAL VELOCITY:	51.0	FPM
ADSORBENT BED HEIGHT:	12.70	FT.
L/D:	1.34	
CONTACT TIME:	14.95	SEC.
NUMBER OF DRUMS:	180	DRUMS
NUMBER OF PALLETS:	45	PALLETS
AMOUNT OF ADSORBENT:	30600	LBS.
VESSEL HEIGHT USED:	16	FT.
EST LIFE OF ADSORBENT:	10.4	YRS.
HgA BED PD:	8.9	PSI.
FLOW DIRECTION:	DOWN	FLOW
PIPE SIZE; USED:	14	IN.
CERAMIC SUPPORT BALLS:	6	IN.(RECOMMENDED)
CERAMIC HOLD-DOWN BALLS:	6	IN.(RECOMMENDED)

THIS DESIGN PLAN HAS BEEN PREPARED IN ACCORDANCE WITH GUIDELINES PROVIDED BY SME ASSOCIATES REFLECTING ITS PAST EXPERIENCE AND LABORATORY TESTING OF THIS PRODUCT. PLEASE DO NOT DEVIATE FROM THIS DESIGN PLAN WITHOUT CONSULTING US FIRST. NO SPECIFIC WARRANTY, EXCEPT FITNESS FOR PURPOSE, IS OFFERED. THIS DESIGN IS NOT A LICENSE TO USE PATENTS OWNED BY OTHERS.

DEQ 000344



Robert Moss <[rmoss@dkrwaf.com](mailto:rmoss@dkrwaf.com)>  
11/12/2007 10:30 AM

To "Susan\_Bassett@URSCorp.com"  
<[Susan\\_Bassett@URSCorp.com](mailto:Susan_Bassett@URSCorp.com)>  
cc  
bcc  
Subject FW: Mercury Removal from Syngas

Susan,

Attached is the vendor sheet (different than the one you sent this morning). Also, note below that there are two carbon beds and no third bed.

Bob Moss  
Development Engineer  
DKRW Advanced Fuels  
713-425-6533 (O)  
713-670-4544 (M)  
[rmoss@dkrwaf.com](mailto:rmoss@dkrwaf.com)  
[www.dkrwaf.com](http://www.dkrwaf.com)  
[www.dkrwenergy.com](http://www.dkrwenergy.com)

This e-mail is the property of DKRW Energy LLC and/or its relevant affiliate and may contain confidential and privileged material for the sole use of the intended recipient (s). Any review, use, distribution or disclosure by others is strictly prohibited. If you are not the intended recipient (or authorized to receive for the recipient), please contact the sender or reply to DKRW Energy LLC at [info@DKRWenergy.com](mailto:info@DKRWenergy.com) and delete all copies of the message. This e-mail (and any attachments hereto) are not intended to be an offer (or an acceptance) and do not create or evidence a binding and enforceable contract between DKRW Energy LLC (or any of its affiliates) and the intended recipient or any other party, and may not be relied on by anyone as the basis of a contract by estoppel or otherwise. Thank you.

**From:** Bonnell, Leo [<mailto:Leo.Bonnell@snc-lavalin-gds.com>]  
**Sent:** Monday, November 12, 2007 10:38 AM  
**To:** Robert Moss  
**Cc:** Ray Birch  
**Subject:** FW: Mercury Removal from Syngas

Robert,

Attached is the vendor data sheet for the Mercury Guard Beds that was used for the Feasibility Study.

I had forgotten, but with the long 10 year bed life claimed by the vendor, for the F.S. we decided not to put a spare guard bed in. So we would have 2 X 50% capacity beds with the total carbon adsorbent cost of \$135,000.

SNC estimated the purchased costs of the two guard beds to be \$400,000 for both. The "all-in" installed cost estimates were not broken down by item, but based on the data we developed they should be about 2.5 X the purchased costs, or \$ 1 million TIC for the two beds (excluding adsorbent).

Hope this will be helpful.

Regards,  
Leo Bonnell  
Process Director  
SNC-Lavalin Houston

DEQ 000345

Tel. 713-295-4815  
leo.bonnell@snclavalin-gds.com

---

**From:** Daren Scott [mailto:dscott@sme-llc.com]  
**Sent:** Tuesday, June 13, 2006 3:33 PM  
**To:** Bonnell, Leo  
**Cc:** Birch, Ray; Daren Scott  
**Subject:** RE: Mercury Removal from Syngas  
Leo,

Attached is a quick design which would require approx 60,000 lbs of HgA at \$2.25/lb. The lead time would be 16-20 weeks.

I divided the flow into 2 to bring the vessel size to a reasonable value and even at this you have 2- 10' dia vessels. The other option would be to use a single 14' dia vessel.

Most of the required data is on the data sheet but FYI this would give you a 10 year life on the carbon, the maximum temperature is 180F and we have no problems with any of the gas components.

Sincerely;

**Daren Scott**

SME Associates, LLC  
Ph: 281-440-7350  
Fx: 281-440-7353  
Cell: 832-257-6281  
[dscott@sme-llc.com](mailto:dscott@sme-llc.com)

**From:** Bonnell, Leo [mailto:Leo.Bonnell@snclavalin-gds.com]  
**Sent:** Tuesday, June 13, 2006 1:09 PM  
**To:** Daren Scott  
**Cc:** Birch, Ray  
**Subject:** Mercury Removal from Syngas

To: Daren Scott, SME Associates Inc.

Daren,

As I mentioned today, SNC is doing a feasibility study, and later FEED package, for a coal-to-liquids project in Wyoming for DKRW Energy ([www.dkrwenergy.com](http://www.dkrwenergy.com)). The syngas contains mercury from the coal that must be removed prior to desulfurizing and syngas conversion.

Can you give us a budget quote for a mercury removal adsorbent bed for this applicati

Flow and composition of the feed syngas:

Temp = 120 deg F  
Pressure = 945 psia  
Total Flow (lbmoles/hr) = 66,600  
Composition (mole %, dry)  
CO = 38.0

DEQ 000346

H2 = 40.0  
CO2 = 20.0  
CH4 = 0.1  
N2 = 1.75  
H2S = 0.15  
C2+ = nil

Water = saturated  
NH3 = 100 ppm  
Mercury = 10 ppb by volume

Note that the Hg level is based on the highest of several local coal samples.  
The long-term average is likely to be less.

Thanks for your help.

Regards,  
Leo Bonnell  
Process Engineering Consultant  
SNC-Lavalin GDS, Inc.  
9009 West Loop South, Houston, TX 77096  
Office: 713-295-4815 Fax: 713-667-9241



Mercury Guard Bed Design.pdf

**Appendix H**  
**December 2007 HAP Modeling Results**

DEQ 000348

# Appendix H

## December 2007 HAP Modeling Results

### 1.1 INTRODUCTION

Additional hazardous air pollutant (HAP) modeling was performed to support the Prevention of Significant Deterioration (PSD) permit application for the Medicine Bow Fuel & Power (MBFP) industrial gasification & liquefaction plant (the Plant). New modeling was necessary due to increased HAP emissions from the revised Plant process design to produce gasoline instead of diesel.

Figure H-1 is a representative layout of the facility showing receptors and sources included in the modeling analysis.

**Figure H-1. Facility Layout and Receptors**

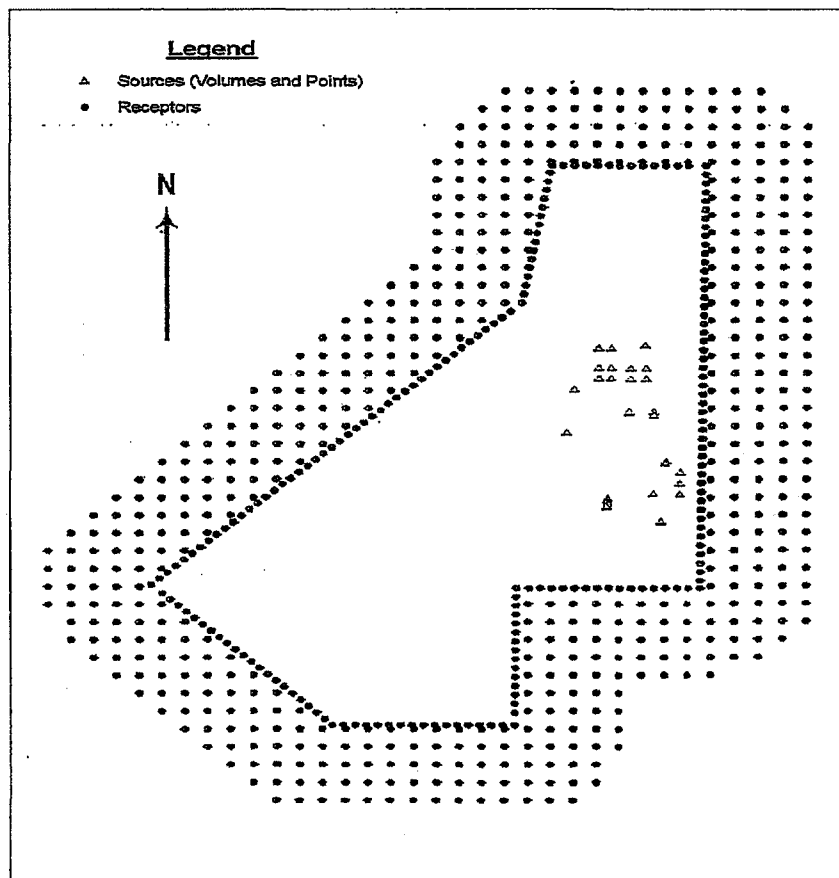
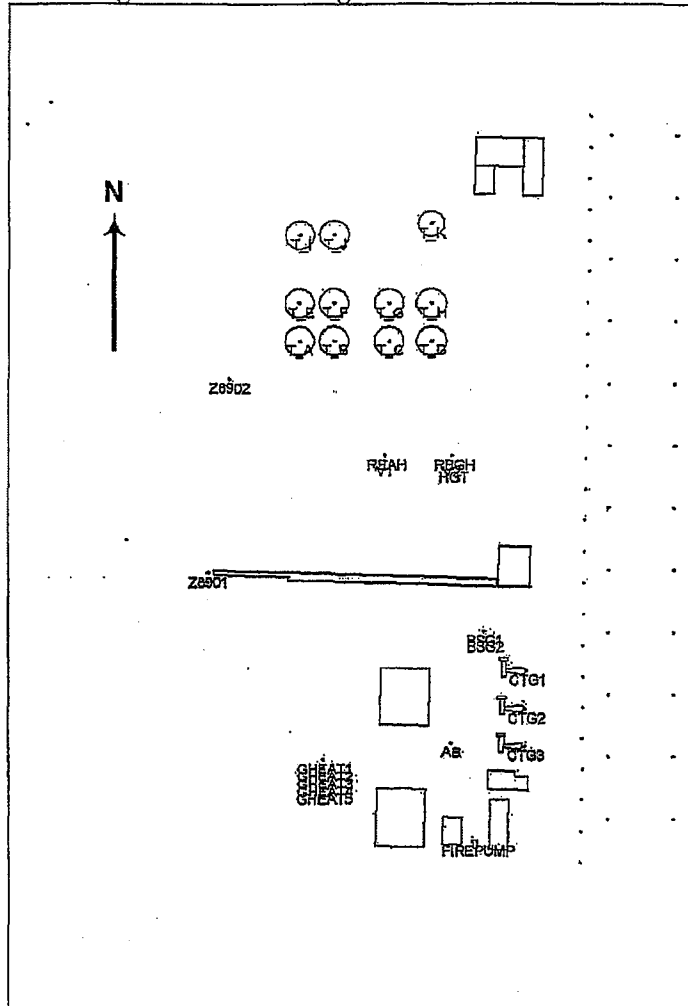


Figure H-2 is a close-up view of the sources and buildings with labels that match source designations in Table H-1 and Table H-2.

**Figure H-2. Building and Source Locations**



## 1.2 HAP EMISSION SOURCES

Eight point source stacks (mostly heaters) that were modeled in the previous modeling analysis were not included in this analysis because they are not needed to produce gasoline and therefore have been deleted from the proposed facility. Five point sources were added including an auxiliary boiler, a regeneration heater, a reactivation heater, a heavy gasoline treatment (HGT) reactor charge heater, and a low pressure flare. Table H-1 shows a complete listing of the point sources modeled for this analysis and Table H-2 shows volume sources.

Due to increased fugitive emissions from the product storage tanks, eleven volume sources were allocated for the storage tank emissions. Gasoline is more volatile than diesel and the quantity of gasoline produced is much greater than diesel production would have been so more tanks were added to the design. Eight tanks are gasoline storage



Table H-1. Point Source Modeling Parameters

Source ID (in model)	Source Type	Source Description	Easting (x, m)	Northing (y, m)	Base Elevation (m)	Stack Height (m)	Temperature (K)	Exit Velocity (m/s)	Stack Diameter (m)
CTG1	Point	Turbine	391370.9	4623839	2115.03	45.73	366.49	7.65	5.79
CTG2	Point	Turbine	391369.2	4623777	2115.19	45.73	366.49	7.65	5.79
CTG3	Point	Turbine	391367.5	4623717	2113.97	45.73	366.49	7.65	5.79
GHEAT1	Point	Gasifier Preheater	391050.6	4623694	2117.34	25.91	422.05	7.45	0.41
GHEAT2	Point	Gasifier Preheater	391050.2	4623681	2116.41	25.91	422.05	7.45	0.41
GHEAT3	Point	Gasifier Preheater	391049.9	4623669	2115.6	25.91	422.05	7.45	0.41
GHEAT4	Point	Gasifier Preheater	391049.6	4623657	2114.91	25.91	422.05	7.45	0.41
GHEAT5	Point	Gasifier Preheater	391049.2	4623645	2114.5	25.91	422.05	7.45	0.41
Z8901	Point	High Pressure Flare	390868.1	4624066	2144.26	91.46	1273.00	20.0	13.60
BSG1 <sup>1</sup>	Point	Black Start Generator	391303.8	4623902	2117.48	30.00 <sup>1</sup>	767.60	1.96	0.41
BSG21	Point	Black Start Generator	391303.5	4623893	2117.57	30.00 <sup>1</sup>	767.60	1.96	0.41
FIREPUMP	Point	Fire Water Pump	391286.3	4623564	2103.98	6.10	739.27	45.00	0.15
AB	Point	Auxiliary Boiler	391252.1	4623722	2103.7	15.24	422.05	1.60	0.91
REGH	Point	Regeneration Heater	391252.1	4624184	2115.4	15.24	422.05	1.60	0.91
REAH	Point	Reactivation Heater	391147.8	4624184	2119.2	15.24	422.05	1.60	0.91
HGT	Point	HGT Reactor Charge Heater	391252.1	4624164	2115.9	15.24	422.05	1.60	0.91
Z8902	Point	Low Pressure Flare	390901.1	4624308	2130.1	65.00	1273.00	20.00	13.60

1. The emissions from three Black Start Generators have been equally divided among two stacks. The stack heights for these sources were increased to 30 meters after initially predicting high formaldehyde concentrations. The 30-meter stacks do not exceed Good Engineering Practice (GEP) stack heights.

Table H-2. Volume Source Modeling Parameters

Source ID (in model)	Source Type	Source Description	Easting (X) (m)	Northing (Y) (m)	Base Elevation (m)	Release Height (m)	Sigma y (initial dimension) (m)	Sigma z (initial dimension) (m)
T_A	Volume	Gasoline Tank	391011	4624368	2124.85	14.6304	10.6325581	2.32
T_B	Volume	Gasoline Tank	391065.9	4624368	2123.19	14.6304	10.6325581	2.32
T_C	Volume	Gasoline Tank	391153.9	4624368	2120.26	14.6304	10.6325581	2.32
T_D	Volume	Gasoline Tank	391219.8	4624368	2116.06	14.6304	10.6325581	2.32
T_E	Volume	Gasoline Tank	391011	4624429	2127.74	14.6304	10.6325581	2.32
T_F	Volume	Gasoline Tank	391065.9	4624429	2127.19	14.6304	10.6325581	2.32
T_G	Volume	Gasoline Tank	391153.9	4624429	2123.04	14.6304	10.6325581	2.32
T_H	Volume	Gasoline Tank	391219.8	4624429	2117.6	14.6304	10.6325581	2.32
T_I	Volume	Methanol Tank	391011	4624538	2128.52	14.6304	10.6325581	2.32
T_J	Volume	Methanol Tank	391065.9	4624538	2127.12	14.6304	10.6325581	2.32
T_K	Volume	Heavy Gas Tank	391218.4	4624557	2117.9	14.6304	9.21488372	2.32
V1	Volume	Equipment Leaks	391147.8	4624174	2119.77	2.5	4.65116279	4.65
V2	Volume	Equipment Leaks	391252.1	4624174	2115.67	2.5	4.65116279	4.65

tanks, two are methanol storage tanks, and the other is a heavy gasoline tank. Total emissions for each pollutant were divided equally among the eleven tank volume sources. Each tank volume source release height was set equal to the tank's height.

Two ground-based volume sources were also modeled to represent fugitive HAP emissions associated with process equipment leaks. These two fugitive HAP volume sources are geographically located in the synthesis process areas of the Plant and were given a release height of 2 meters. Total equipment leak emissions for each pollutant were divided equally between the two fugitive volume sources. Table H-2 has a complete listing of the volume sources for this modeling analysis.

### 1.3 HAP RISK ASSESSMENT PROCEDURES

HAP emissions were modeled and compared to the appropriate corresponding USEPA thresholds in order to evaluate the potential health risks due to short-term and long-term exposures. Benzene, formaldehyde, xylene, toluene, and methanol maximum 1-hour (short-term) averaged concentrations are compared to the Reference Exposure Levels (RELs) obtained from the EPA Air Toxics Database, Table 2 (EPA, 2005a). An REL is defined as the concentration level at or below which no adverse health effects are anticipated for a specified exposure duration. The REL is designed to protect the most sensitive individuals in the population. Exceeding the REL does not automatically indicate an adverse health impact.

No RELs are available for ethylbenzene and n-hexane. Instead, the available Immediately Dangerous to Life or Health values divided by 100 (IDLH/100) were used. Dividing by 100 is a very conservative approach to reduce a pollutant's concentration threshold of concern to only 1 percent of the level that is considered to be "immediately dangerous." IDLH values are determined by the National Institute for Occupational Safety and Health (NIOSH) and were obtained from the EPA's Air Toxic Database (EPA, 2005a). The maximum of the two short-term (grams per second) emission rates due to cold startup and normal operations for each pollutant and source were modeled and are shown in Table H-3. For example, for a particular pollutant, several sources' emissions will be highest during startup (generators) and other sources' emissions are highest during normal operations (tank operations at full plant production). For each type of source, the highest emission rates (from startup or normal operations) were modeled simultaneously to conservatively estimate air quality impacts.

Table H-3. Source HAP Emission Rates

Source ID (in model)	Formaldehyde (g/sec)	Benzene (g/sec)	Methanol (g/sec)	n-Hexane (g/sec)	Toluene (g/sec)	Ethyl benzene (g/sec)	Xylene (g/sec)
CTG1	0.007024	0.001187	0.000000	0.000000	0.012862	0.003166	0.006332
CTG2	0.007024	0.001187	0.000000	0.000000	0.012862	0.003166	0.006332
CTG3	0.007024	0.001187	0.000000	0.000000	0.012862	0.003166	0.006332
GHEAT1	0.000195	0.000005	0.000000	0.004669	0.000009	0.000000	0.000000
GHEAT2	0.000195	0.000005	0.000000	0.004669	0.000009	0.000000	0.000000
GHEAT3	0.000195	0.000005	0.000000	0.004669	0.000009	0.000000	0.000000
GHEAT4	0.000195	0.000005	0.000000	0.004669	0.000009	0.000000	0.000000
GHEAT5	0.000195	0.000005	0.000000	0.004669	0.000009	0.000000	0.000000
Z8901	0.000000	0.000000	0.000000	0.000000	0.000000	0.000000	0.000000
BSG1	0.194544	0.000781	0.000000	0.000409	0.001503	0.000000	0.000678
BSG2	0.194544	0.000781	0.000000	0.000409	0.001503	0.000000	0.000678
FIREPUMP	0.000573	0.000453	0.000000	0.000000	0.000199	0.000000	0.000138
AB	0.000611	0.000017	0.000000	0.014675	0.000028	0.000000	0.000000
REGH	0.000065	0.000002	0.000000	0.001554	0.000003	0.000000	0.000000
REAH	0.000145	0.000004	0.000000	0.003476	0.000007	0.000000	0.000000
HGT	0.000614	0.000001	0.000000	0.000494	0.000001	0.000000	0.000000
Z8902	0.000000	0.000000	0.000000	0.000000	0.000000	0.000000	0.000000
T_A	0.000000	0.001508	0.006837	0.001418	0.001625	0.000109	0.000458
T_B	0.000000	0.001508	0.006837	0.001418	0.001625	0.000109	0.000458
T_C	0.000000	0.001508	0.006837	0.001418	0.001625	0.000109	0.000458
T_D	0.000000	0.001508	0.006837	0.001418	0.001625	0.000109	0.000458
T_E	0.000000	0.001508	0.006837	0.001418	0.001625	0.000109	0.000458
T_F	0.000000	0.001508	0.006837	0.001418	0.001625	0.000109	0.000458
T_G	0.000000	0.001508	0.006837	0.001418	0.001625	0.000109	0.000458
T_H	0.000000	0.001508	0.006837	0.001418	0.001625	0.000109	0.000458
T_I	0.000000	0.001508	0.006837	0.001418	0.001625	0.000109	0.000458
T_J	0.000000	0.001508	0.006837	0.001418	0.001625	0.000109	0.000458
T_K	0.000000	0.001508	0.006837	0.001418	0.001625	0.000109	0.000458
V1	0.000000	0.150111	0.149600	0.000000	0.000000	0.000000	0.000000
V2	0.000000	0.150111	0.149600	0.000000	0.000000	0.000000	0.000000

## 1.4 MODELING RESULTS

### 1.4.1 Maximum 1-Hour HAP Concentrations

Table H-4 shows the highest short-term (1-hour) averaged concentrations using worst-case assumptions and the corresponding RELs. Each of the seven modeled HAPs has a predicted maximum 1-hour concentration less than the applicable REL.

**Table H-4. Source HAP Emission Rates**

HAP	Maximum 1-hour Averaged Modeled Concentrations (µg/m³)	Reference Exposure Levels (RELs) (µg/m³)
Benzene <sup>1</sup>	1087.43	1300
Toluene <sup>1</sup>	4.09	37000
Ethylbenzene <sup>2</sup>	0.28	35000
Xylene <sup>1</sup>	1.23	22000
n-Hexane <sup>2</sup>	5.98	39000
Formaldehyde <sup>1</sup>	74.65	94
Methanol <sup>1</sup>	1722.56	28000

1. EPA Air Toxics Database, Table 2 (EPA, 2005b).

2. No REL available for these HAPs. Values shown are from (IDLH/100) EPA Air Toxics Database, Table 2 (EPA, 2005b).

#### 1.4.2 Maximum Annual HAP Concentrations

Annually averaged modeled HAP concentrations due to normal operations were compared to the Reference Concentrations for Chronic Inhalation (RfCs). An RfC is defined by the EPA as the daily inhalation concentration (maximum annually averaged for this analysis) at which no long-term adverse health effects are expected. RfCs exist for both non-carcinogenic and carcinogenic effects on human health (EPA, 2005b). Annually averaged modeled benzene, methanol, toluene, ethylbenzene, xylene, n-hexane, and formaldehyde concentrations were compared to the non-carcinogenic RfCs shown in Table H-5. Maximum annual predicted concentrations are well below the applicable RfCs for each pollutant.

**Table H-5. Annually Averaged Ambient Concentrations**

HAP	Maximum Annually Averaged Modeled Concentrations (µg/m³)	Non-Carcinogenic (RfCs) (µg/m³)
Benzene	20.69	30
Toluene	0.075	400
Ethyl benzene	0.005	1000
Xylene	0.021	100
n-Hexane	0.068	200
Formaldehyde	0.004	9.8
Methanol	20.73	4000

1. EPA Air Toxics Database, Table 1 (EPA, 2005c).

### 1.4.3 Carcinogen Analysis

RfCs for suspected carcinogens benzene and formaldehyde are expressed as unit risk factors and accepted methods for risk assessment are used to evaluate the incremental cancer risk for these pollutants. The maximum annually averaged modeled concentration for each pollutant is multiplied by EPA's unit risk factors (URF) (based on 70-year exposure), and then multiplied by an adjustment factor which represents the ratio of projected exposure time to 70 years. The adjustment factors represent two scenarios: a most likely exposure (MLE) scenario and one reflective of the maximally exposed individual (MEI).

The MLE duration is assumed to be 9 years, which corresponds to the mean duration that a family remains at a residence (EPA, 1993). This duration corresponds to an adjustment factor of  $9/70 = 0.13$ . The duration of exposure for the MEI is assumed to be 70 years and the corresponding adjustment factor is 1.0.

A second adjustment is made for time spent at home versus time spent elsewhere. For the MLE scenario, the at-home time fraction is 0.64 (EPA, 1993), and it is assumed that during the rest of the day the individual will remain in an area where annually averaged HAP concentrations would be one-quarter as large as the maximum annual average concentration. Therefore, the MLE adjustment factor is calculated as follows.

$$\text{MLE Adjustment Factor} = (0.13) \times [(0.064 \times 1.0) + (0.36 \times 0.25)] = 0.095.$$

The MEI scenario assumes that the individual is at home 100 percent of the time, for the final adjustment factor of  $(1.0 \times 1.0) = 1.0$ . The values for the cancer risk assessment are shown in Table H-6.

Table H-6. Cancer Risk Assessment Values

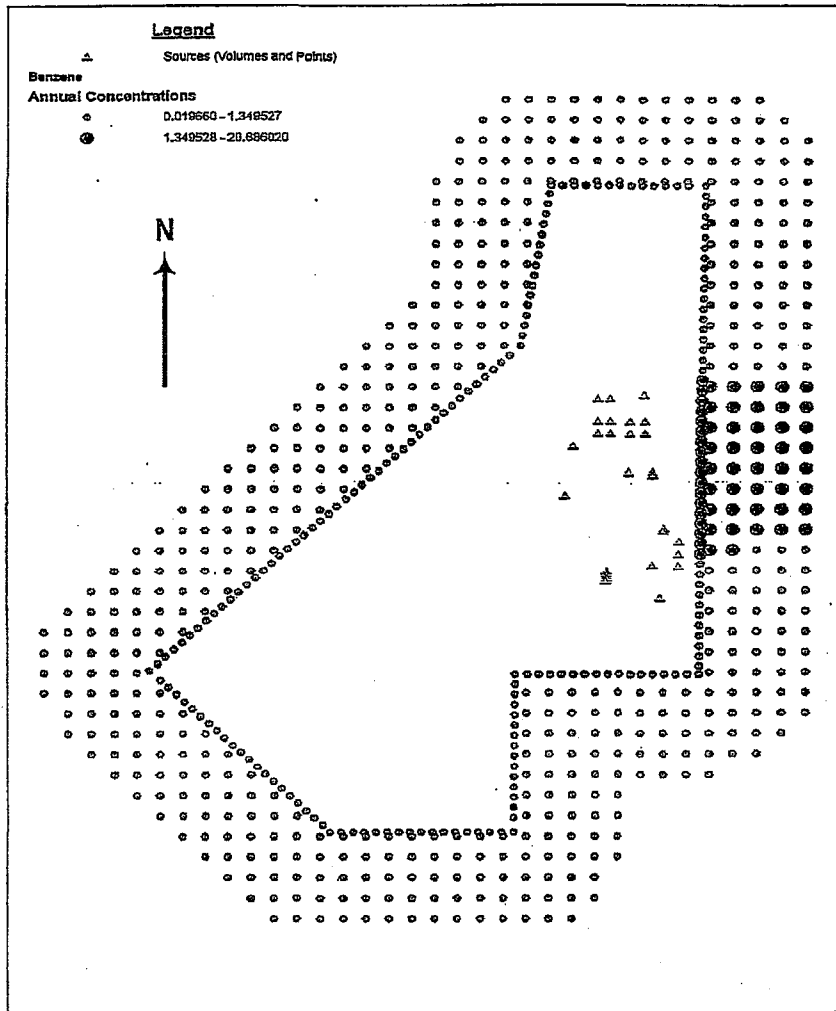
Analysis	HAP	Carcinogenic RfC (Risk Factor) ( $\mu\text{g}/\text{m}^3$ )	Exposure Adjustment Factor	Maximum/Annually Averaged Modeled Concentrations ( $\mu\text{g}/\text{m}^3$ )	Estimated Long-Term Exposure Risk
MLE	Benzene	7.80E-06	0.095	20.69	1.53E-05
MLE	Formaldehyde	5.50E-09	0.095	0.004	2.09E-12
MEI	Benzene	7.80E-06	1	20.69	1.61E-04
MEI	Formaldehyde	5.50E-09	1	0.004	2.2E-11

1. EPA Air Toxics Database, Table 1 (EPA, 2005c).

Figures H-3 and H-4 show the receptor locations with respect to the Plant including the maximum annually averaged concentrations for benzene for each receptor. Concentration ranges are colored based on the incremental cancer risk analysis. Figure H-3 corresponds to the MLE and Figure H-4 corresponds to the MEI. Each red dot represents receptors that have concentrations that are at a  $1 \times 10^{-6}$  (1-in-a-million) risk or greater of developing cancer. Black receptors indicate a lower risk of developing cancer. Formaldehyde concentrations do not translate to the  $1 \times 10^{-6}$  risk threshold and therefore are not shown graphically.

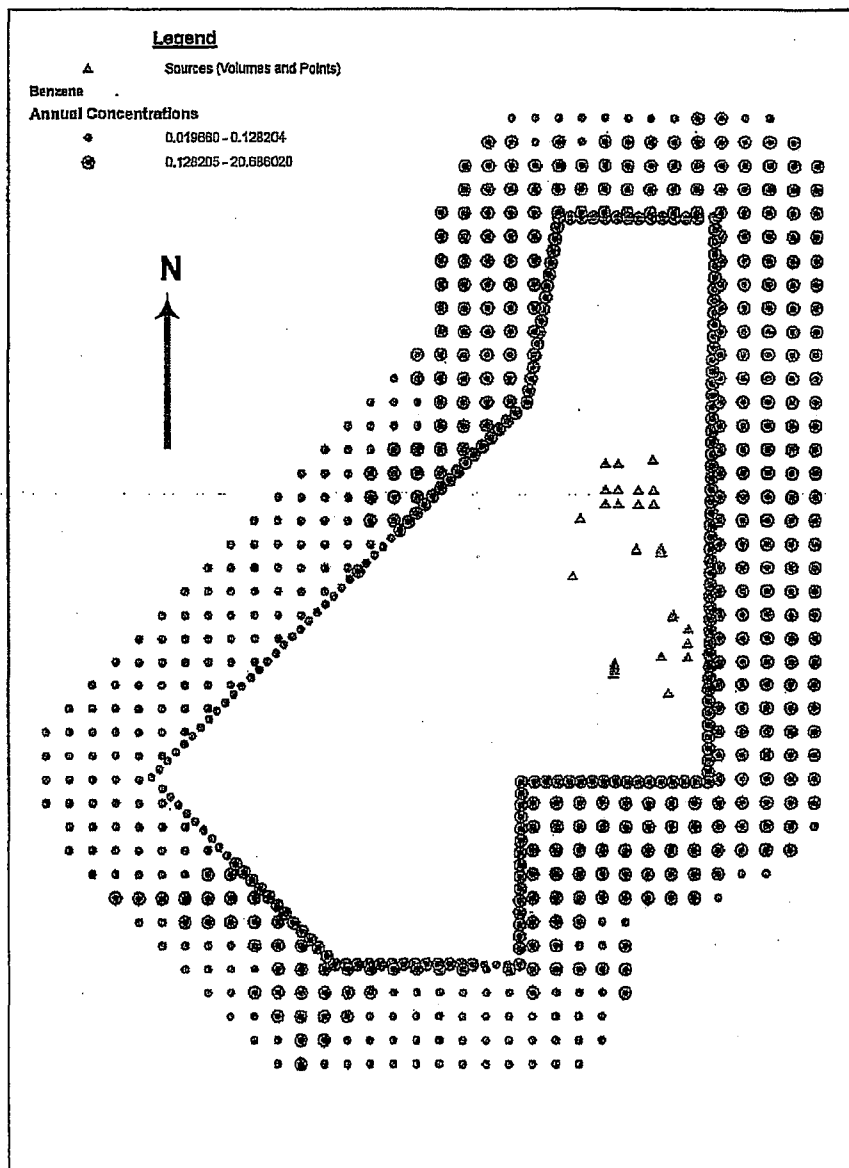
For the MLE analysis; a concentration of  $1.349528 \mu\text{g}/\text{m}^3$  corresponds to a  $1 \times 10^{-6}$  risk of developing cancer due to benzene exposure from Plant emissions.

Figure H-3. MLE Receptors for Benzene



For the MEI exposure analysis; a concentration of  $0.128205 \mu\text{g}/\text{m}^3$  corresponds to  $1 \times 10^{-6}$  risk.

Figure H-4. MEI Receptors for Benzene





## 1.5 CONCLUSION

All maximum 1-hour and maximum annual predicted HAP concentrations are below the applicable RELs and RfCs, respectively. Based on these recognized EPA thresholds, short-term HAP exposure resulting from Plant emissions meets applicable criteria.

With regard to carcinogenic pollutants, predicted formaldehyde concentrations do not exceed a  $1 \times 10^{-6}$  risk at any modeled receptor. In contrast, benzene concentrations do exceed this risk threshold at some locations. MLE greater than  $1 \times 10^{-6}$  risk occurs only along the east side of the Plant, while MEI exposure greater than  $1 \times 10^{-6}$  risk occurs along the south, east, and north Plant boundaries. The  $1 \times 10^{-6}$  MEI risk begins to fade away at 500 meters from the south and north Plant boundaries. To the east, MEI exposures greater than  $1 \times 10^{-6}$  risk extend beyond 500 meters.

The closest residence, viewed in aerial photographs, is 3.3 kilometers to the south of the Plant. Consequently, occupants of this residence would have significantly less than  $1 \times 10^{-6}$  risk of developing cancer due to exposure to Plant emissions of benzene or formaldehyde. As shown in the wind rose in Section 6.4 of the permit application document, prevailing winds blow from the west or west-southwest more than 52 percent of the time. Winds blowing from the north are extremely rare.

**Appendix I**  
**Analysis of June 2007 Criteria Pollutant Modeling Sufficiency**

## Appendix I

### Analysis of Criteria Pollutant Modeling Sufficiency

#### 1.1 INTRODUCTION

Medicine Bow Fuel & Power LLC (MBFP) believes that the near field and far field criteria pollutant modeling performed for the June 19, 2007 permit application remains sufficient for the revised permit application. The following pollutant-specific discussions compare modeled emission rates to emissions rates included in this revised application.

Emissions from the industrial gasification and liquefaction plant (the Plant) have been revised due to a number of process and equipment changes. Emission unit changes are summarized in Table I-1. The combustion turbines are the largest emitters of nitrogen oxides (NO<sub>x</sub>), carbon monoxide (CO), and sulfur dioxide (SO<sub>2</sub>). The turbines are also the largest point source emitters of particulate matter with a diameter of less than 10 microns (PM<sub>10</sub>). Combustion turbine stack parameters are not expected to change significantly and the location of the turbines has not changed. Consequently, prior modeling of turbine emissions should be adequate.

With regard to other emission sources, many units do not change. However, the Sulfur Recovery Unit (SRU) incinerator has been removed from the process. Furthermore, many process heaters have been deleted while a few new process heaters have been added.

**Table I-1 – Emission Unit Changes**

Description	Identifier	Size
<i>Equipment with no Capacity Changes</i>		
Combustion Turbine 1	CT-1	66 MW
Combustion Turbine 2	CT-2	66 MW
Combustion Turbine 3	CT-3	66 MW
Black Start Generator 1 <sup>1</sup>	Gen-1	2889 hp
Black Start Generator 2 <sup>1</sup>	Gen-2	2889 hp
Black Start Generator 3 <sup>1</sup>	Gen-3	2889 hp
Firewater Pump Engine <sup>1</sup>	FW-Pump	575 hp
CO <sub>2</sub> Vent Stack <sup>1</sup>	CO <sub>2</sub> VS	N/A
High Pressure Flare	FL-1	0.2 MMBtu/hr (for pilot)
<i>Added Equipment</i>		
Auxiliary Boiler <sup>2</sup>	AB	66.0 MMBtu/hr
Catalyst Regenerator <sup>1,3</sup>	B-1	21.5 MMBtu/hr
Reactivation Heater <sup>1</sup>	B-2	12.5 MMBtu/hr
HGT Reactor Charge Heater <sup>1</sup>	B-3	2.2 MMBtu/hr
Low Pressure Flare	FL-2	0.2 MMBtu/hr (for pilot)

**Table I-1 – Emission Unit Changes**

Description	Identification	Size
<i>Removed Equipment</i>		
Fractionation Feed Heater	H-5401	87 MMBtu/hr
Catalytic Dewaxing Charge Unit	H-5301	3.9 MMBtu/hr
Unicracker Feed Heater	H-5201	16.3 MMBtu/hr
Unicracker Intermediate Heater	H-5202	44.2 MMBtu/hr
Unionfiner Feed Heater	H-5101	5.1 MMBtu/hr
Unionfiner Intermediate Heater	H-5102	6.4 MMBtu/hr
Sulfur Recovery Unit Incinerator	H-3102	11.2 MMBtu/hr
<i>Modified Equipment</i>		
Gasifier Preheater 1 <sup>1,4</sup>	GP-1	21 MMBtu/hr
Gasifier Preheater 2 <sup>1,4</sup>	GP-2	21 MMBtu/hr
Gasifier Preheater 3 <sup>1,4</sup>	GP-3	21 MMBtu/hr
Gasifier Preheater 4 <sup>1,4</sup>	GP-4	21 MMBtu/hr
Gasifier Preheater 5 <sup>1,4</sup>	GP-5	21 MMBtu/hr
<p>1. This equipment operates less than 8,760 hr/yr.</p> <p>2. The auxiliary boiler usually operates on standby at 25% load to prevent freeze ups if there is a Plant shutdown. The equivalent continuous heat input rate would be approximately 21 MMBtu/hr.</p> <p>3. The catalyst regenerator operates only during catalyst regeneration; the average equivalent continuous rate will be approximately 9 MMBtu/hr.</p> <p>4. Gasifier preheater heat input capacity was increased from 15 MMBtu/hr to 21 MMBtu/hr for each preheater.</p>		

Table I-2 summarizes proposed maximum emission rates within this revised application and compares them to modeled emission rates. Emission rates are given in terms of grams per second (g/sec) for easy comparison to modeled rates. Emission rates do not include the following malfunctions: emergency venting to the High Pressure or Low Pressure Flares and CO<sub>2</sub> venting during the first plant startup and as a result of malfunctions thereafter.

**Table I-2 – Revised Emissions Compared to AERMOD Modeled Emissions**

Pollutant	Revised Plant-Wide Maximum Emission Rate (g/sec)	Modeled Plant-Wide Emission Rate (g/sec)	Emission Rate Decrease From Modeled Rates (g/sec)
NO <sub>x</sub>	11.45 <sup>1</sup>	12.55	1.1
CO	15.28 <sup>1</sup>	38.69	26.26
SO <sub>2</sub>	1.03 <sup>1</sup>	1.23	0.20
PM/PM <sub>10</sub>	3.99 <sup>2</sup>	4.75 <sup>2</sup>	0.76
<p>1. Does not include emergency venting to the High Pressure Flare or startup, shutdown, or malfunction (SSM) venting to the Low Pressure Flare. This excludes coal storage emissions (60.2 tpy), which did not change from what was previously modeled.</p>			

## 1.2 NEAR FIELD MODELING

Near field modeling was performed for NO<sub>x</sub>, CO, SO<sub>2</sub>, and PM/PM<sub>10</sub>. On a Plant-wide basis, revised emission rates for all near field modeled pollutants are less than the modeled rates shown in Table I-2. Although emission rates would increase from some emission units, these unit-specific changes are not believed to be significant enough to necessitate additional near field modeling. Stack parameters (particularly exit velocity and stack height) used during the previous modeling are not expected to change significantly.

### 1.2.1 NO<sub>x</sub> Modeling

As shown in Table I-2, maximum Plant-wide NO<sub>x</sub> emission rates are approximately 1.1 g/sec less than the emission rates used for AERMOD modeling. The largest NO<sub>x</sub> emitters at the Plant continue to be the three combustion turbines, whose location and capacity have not changed. These turbines account for more than 95 percent of total annual emissions during normal operations.

Changes to process heating equipment (including the new auxiliary boiler) affect NO<sub>x</sub> emissions, with a net decrease in annual NO<sub>x</sub> emissions from these combustion units. The added auxiliary boiler will be located near the Plant's power generation equipment. The three new process heaters will be located in the same general vicinity as the previous six process heaters.

Since there is a decrease in emissions and equipment changes will occur in largely the same areas as the modeled emission sources, MBFP believes that additional NO<sub>x</sub> modeling is not necessary. Furthermore, the maximum predicted annual NO<sub>x</sub> concentration is less than 4 percent of the Wyoming Ambient Air Quality Standards (WAAQS) and less than 13 percent of the Prevention of Significant Deterioration (PSD) Class II increment. Consequently, predicted NO<sub>x</sub> concentrations are well below all regulatory thresholds of concern.

### 1.2.2 CO Modeling

CO is the only modeled criteria pollutant whose Plant-wide emissions will increase. Based on normal operations, Plant-wide CO emissions will increase from 140.2 tpy to 146.8 tpy. This emission increase does not, however, necessitate additional near field modeling because previous modeling was based on high CO emission rates for the combustion turbines.

The combustion turbines and black start generators have the highest CO emission rates and the turbines have the greatest annual emissions. The capacities and locations of these emission units have not changed from the original permit application. Total Plant CO emissions were modeled at 38.69 g/sec. The combustion turbines accounted for approximately 78 percent of this total. Each combustion turbine was modeled with a CO emission rate of 10.10 g/sec, which is significantly greater than the cold startup worst-case hourly emission rate of 6.15 g/sec (equivalent to 48.77 lb/hr). Based on revised emission calculations for the turbines and other CO-emitting sources, maximum hourly

Plant emissions are expected to be 15.28 g/sec, which is far less than the modeled 38.69 g/sec.

In addition, maximum predicted hourly CO concentrations are less than 12 percent of the WAAQS, while maximum predicted annual CO concentrations are less than 14 percent of the WAAQS. (There are no PSD Class II increments for CO.) MBFP believes that additional modeling of CO is not necessary.

### 1.2.3 SO<sub>2</sub> Modeling

Removal of the Sulfur Recovery Unit (SRU) incinerator has deleted the largest single source of SO<sub>2</sub> emissions. However, this reduction in SO<sub>2</sub> emissions has been largely offset by increases in SO<sub>2</sub> emissions from the three combustion turbines. The combustion turbine emission increases derive in part from firing more natural gas, which has a greater sulfur concentration than the syngas that was originally expected to be fired in the turbines. In addition, the SO<sub>2</sub> emission factor for natural gas firing that was used in the emission calculations submitted with the original permit application was too low.

As shown in Table I-2, modeled Plant SO<sub>2</sub> emissions are greater than revised emission estimates, with modeled emissions of 1.23 g/sec, compared to revised emissions of 1.03 g/sec. The location of these emissions has will move southeast from the original location of the SRU incinerator to the Plant's Power Block. The new location is closer to the eastern Plant boundary. However, maximum predicted ambient concentrations of SO<sub>2</sub> over the five years modeled are far below the WAAQS. Table I-3 summarizes the modeled SO<sub>2</sub> impacts and compares them to the WAAQS and to allowable PSD Class II area increments. Even with source locations closer to the east boundary of the Plant, ambient impacts would not be likely to exceed allowable levels.

**Table I-3 – Modeled SO<sub>2</sub> Air Quality Impacts**

Averaging Period	Maximum Predicted Concentration (µg/m <sup>3</sup> )	WAAQS (µg/m <sup>3</sup> )	Percentage of WAAQS (%)	PSD Class II Allowable Increment (µg/m <sup>3</sup> )	Percentage of Increment (%)
Annual	1.08	60	<2	20	<6
24-Hour Highest	12.24	260	<5	91	<14
3-Hour Highest	72.9	1300	<6	512	<15

### 1.2.4 PM/PM<sub>10</sub> Modeling

While coal storage PM<sub>10</sub> emissions have not changed (because coal usage has not changed), PM<sub>10</sub> emissions from combustion sources have decreased substantially. The modeled emission rate for combustion sources was 4.75 g/sec compared to only 3.99 g/sec based on revised emissions. Removal of the SRU incinerator accounts for a large share of the PM<sub>10</sub> emission decrease. Decreased total heat input to process heaters also played a role.

Maximum predicted annual and 24-hour PM/PM<sub>10</sub> concentrations are both less than 5 percent of the WAAQS. Furthermore, the concentrations are well below the PSD Class II increments at less than 14 percent and less than 25 percent of the annual and 24-hour increments, respectively. Due to the significant decrease in PM<sub>10</sub> emissions and the fact that the source locations for the largest PM<sub>10</sub> emission sources (turbines and coal storage) have not changed, MBFP believes that additional PM<sub>10</sub> modeling is not required.

### 1.3 FAR FIELD MODELING

Far field modeling was performed using CALPUFF to predict air quality impacts relating to visibility and nitrogen and sulfur deposition. The modeled pollutants that contribute to these air quality impacts are NO<sub>x</sub>, SO<sub>2</sub>, and PM<sub>10</sub>. Plant-wide gram per second emissions of each of these pollutants decreased. Consequently, far field impacts are expected to be less significant than shown by previous modeling. MBFP believes that additional far field modeling is not necessary.

**Appendix J**  
**Responses to WDEQ July 17, 2007 Modeling Comments**



**Air Quality Impact Analysis**

**Responses to Wyoming Air Quality Division – DKRW Medicine Bow**

**October 17, 2007**

**Air Quality Impact Analysis**  
**Responses to Wyoming Air Quality Division – DKRW Medicine Bow**  
**October 17, 2007**

**Near-Field (AERMOD) Impact Analysis**

**1. Section 6: Near Field (AERMOD) Impact Analysis**

**Comment.** A letter from the Division dated March 5, 2007 provided comments on the modeling protocols that were submitted for the project. Item A.3 of the letter requested background information on the quality of the meteorological data from the Elmo site, specifically: *"documentation of QA/QC procedures that were utilized at the Elmo site during the period of monitoring that will be used for input to the modeling. This should include records of system calibrations and audits"*. This information was not provided in the application.

**Response.** Meteorological data collected at the Elmo (Seminole mine) monitoring station was used for the years 2000, 2001, 2003, 2004, and 2005. Data collected during 2002 was not used because it was not at least 90 percent complete. Inter-Mountain Labs (IML) operated the meteorological station in accordance with *Meteorological Monitoring Guidance for Regulatory Modeling Applications* (EPA-454/R-99-005). IML performed semi-annual quality assurance audits on the station and the IML staff conducted quality control procedures on the data. IML submitted quarterly reports (including semiannual quality assurance audits) to Dennis Wuertz at Seminole (Arch of Wyoming, LLC), who then submitted the reports to Bob Schick at the Wyoming Division of Air Quality. Cara Keslar in the Division of Air Quality Monitoring Division may be contacted with regard to this data.

**Comment.** The March 5, 2007 letter included item 6, which stated that the application should include an analysis of additional Class II impacts to include air quality impacts on soils/vegetation with significant commercial or recreational value. This analysis, which is required under the Wyoming Standards and Regulations (WAQSR), Chapter 6, Section 4(b)(i)(B), was not provided in the application.

**Response.** The Air Quality Division (AQD) of the Wyoming Department of Environmental Quality (WDEQ) has requested that DKRW Medicine Bow (Medicine Bow) provide further information regarding potential impacts of its planned facility in Carbon County, Wyoming, and in particular as it relates to potential impacts to nearby soils and vegetation of commercial value.

Medicine Bow believes that the application as originally submitted suggested that surrounding areas were of limited commercial value and, given the relatively minor project impacts, that there should be no additional impacts related to these emissions. The region surrounding the proposed Medicine Bow facility has been described and is shown in Figure 1 (the facility source location is indicated by coordinates). The terrain in the immediate project vicinity is generally rolling with a fairly uniform land cover. Views of

the area were presented in the application (see Figures 6.1 and 6.2 in the application). Comparing these images with that shown in Figure 1 suggests the general lack of commercial or recreational use in the project vicinity.

The potential to emit from the Medicine Bow facility includes four criteria pollutants (CO, NO<sub>x</sub>, SO<sub>2</sub>, and PM/PM<sub>10</sub>) that will be emitted in excess of Prevention of Significant Deterioration (PSD) significant emission levels. The impacts of each of these pollutant emissions from the project would be minimal, as shown in Table 1. Impacts attributable to the Medicine Bow facility are shown in the table and are typically well below 10 percent of the National Ambient Air Quality Standards (NAAQS), with the exception of CO, which is somewhat higher.

**Table 1. Medicine Bow – Maximum Project Impacts Compared to NAAQS**

Pollutant	Averaging Period	Maximum Modeled Concentration over 5 Year Period (µg/m <sup>3</sup> )	NAAQS (µg/m <sup>3</sup> )	Percentage of NAAQS (%)	Class II PSD Increment (µg/m <sup>3</sup> )
CO	1-hour	4268	40,000	10.7	None
	8-hour	1344	10,000	13.4	None
NO <sub>2</sub>	Annual	2.40	100 <sup>1</sup>	2.4	25
PM <sub>10</sub>	24-hour	7.41	150 <sup>1</sup>	4.9	30
	Annual	2.22	50 <sup>2</sup>	6.3 <sup>2</sup>	17
SO <sub>2</sub>	3-hour	72.9	1300 <sup>3</sup>	5.6	512
	24-hour	12.2	365	3.3	91
	Annual	1.08	80	1.4	20

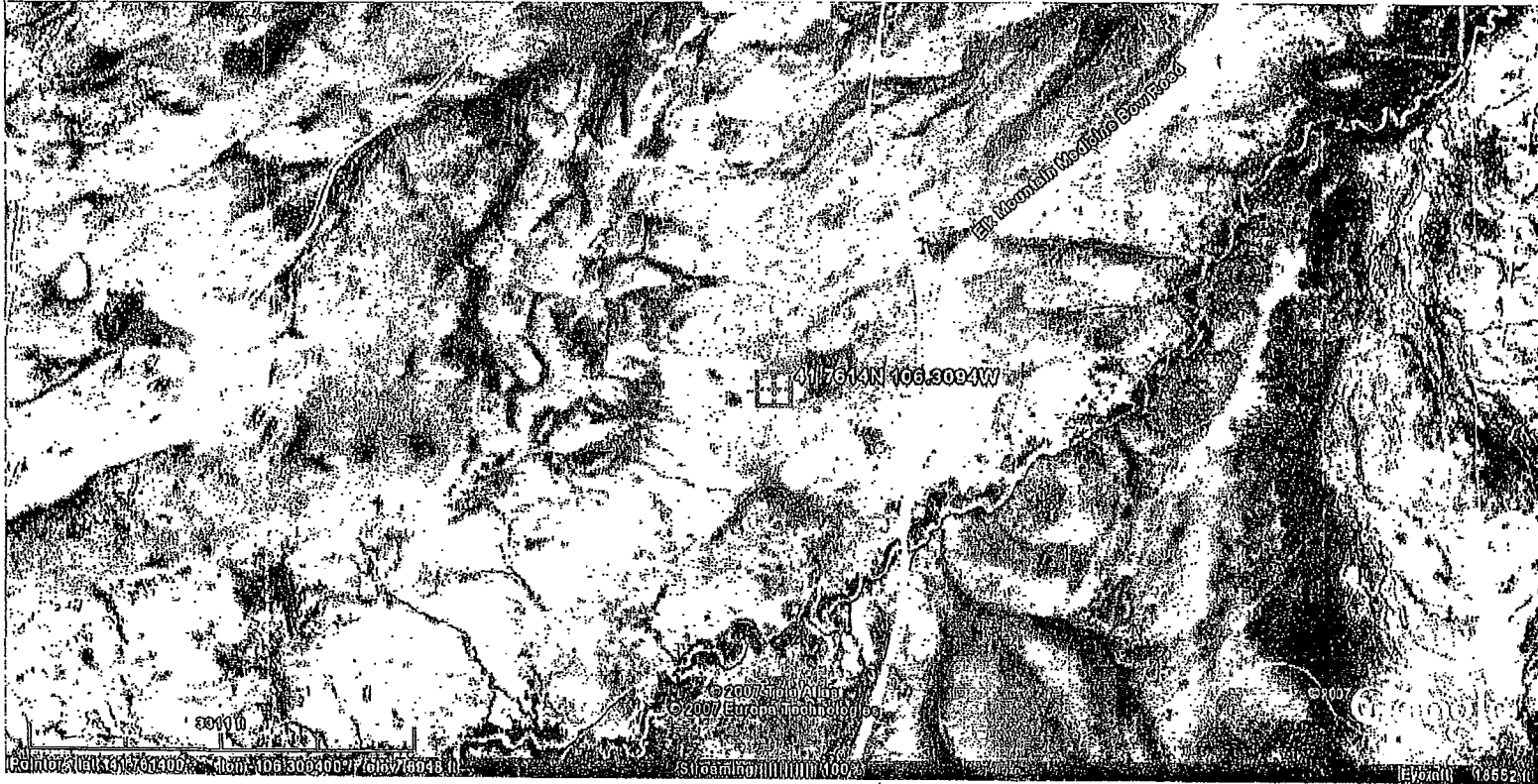
<sup>1</sup> This standard is both a primary standard protecting human health and a secondary standard protecting public welfare (including protection of vegetation, water quality and visibility).

<sup>2</sup> There are no annual PM<sub>10</sub> NAAQS; however, there is a 50 µg/m<sup>3</sup> Wyoming Ambient Air Quality Standard (WAAQS) for PM<sub>10</sub>.

<sup>3</sup> The 3-hour SO<sub>2</sub> NAAQS is a secondary standard, but not a primary standard.

Secondary NAAQS standards are expressly designed to protect public welfare, including protection of soils, vegetation, and other environmental and man-made attributes.

Figure 1 - Aerial View of Land Use Immediately Surrounding the Medicine Bow Facility



### **Soil Impacts**

The US Department of Agriculture (USDA) Natural Resources Conservation Service (NRCS) has compiled a detailed list of agricultural yields and soil types for portions of Carbon County. Of the over 540,000 acres surveyed, land capability is classified as Class 3 or worse (no soils are designated as Class 5). Soil within the surveyed areas of the county is classified as follows:

- Class 3: Soils have severe limitations that reduce the choice of plants or that require special conservation practices, or both.
- Class 4: Soils have very severe limitations that reduce the choice of plants or that require very careful management, or both.
- Class 6: Soils have severe limitations that make them generally unsuitable for cultivation. Rangeland or forestry improvements can be applied.
- Class 7: Soils have very severe limitations that make them unsuitable for cultivation. They can be used for forestry or grazing, but rangeland improvements are impractical.
- Class 8: Soils and miscellaneous areas have limitations that nearly preclude their use for commercial crop production.

Only 1 percent of the surveyed land produces alfalfa or hay without using irrigation. With regard to irrigated land (accounting for a small portion of the county), the most productive land produces up to 5 tons of alfalfa per acre. Assuming a value of \$130/ton of alfalfa, maximum cropland production value is \$650/acre on the best-producing land included in the NRCS survey of Carbon County. Based on this information, most Carbon County land does not have significant commercial value. NRCS crop yields are provided in Attachment 4 [see Appendix K] and in the electronic file "crops carbon county.pdf." The NRCS soil survey is provided in Attachment 5 [see Appendix L] (and in file "soils in carbon county.pdf").

Little information on direct gaseous air pollutant effects on soil is available in the current literature. While certain soils can be an effective sink for gaseous pollutants such as NO<sub>2</sub> and some studies have been done, accurate methods for routinely quantifying the effects of NO<sub>2</sub> and other pollutants on soil in the field do not exist. The rate of adsorption is dependent on the distance from the source, concentrations in the air, soil properties, vegetative cover, and the prevailing hydrological and meteorological conditions. No significant impacts on soils from exposures to acidic gases such as NO<sub>2</sub> occur unless the soils experience a large decrease in buffering capacity and the pH of precipitation drops dramatically (Smith, 1981). Because NO<sub>2</sub> emission increases attributable to the Medicine Bow facility represent only 2.4 percent of the secondary NAAQS for this pollutant, soil impacts are expected to be low.

### **Vegetation Impacts**

The Medicine Bow project area is within what has been termed a gently rolling landscape. The commercial productivity of the lands around the immediate Medicine Bow area is very low. There are some areas with limited agriculture within 10 km of the site. The closest cropland is approximately 2.3 km from the Medicine Bow facility.

Primary land use and vegetation cover is depicted in Figure 2, which shows that the predominant land use is fallow or shrubland. Only a small percentage of the land surrounding the facility is cropland. A review of the Wyoming Department of Agriculture and livestock census suggests that Carbon County lands are generally low in productivity (see Attachment 6 [Appendix M] and the electronic file "rangeland carbon county.pdf").

Damage or injury to plants from air pollutants is caused primarily through foliage injury and not by absorption through the plant roots. As a result, ambient air concentrations of pollutants are the primary indicators of potential impact. The concentration of a pollutant and the duration of the exposure period are collectively referred to as the dose; the lowest dose that produces an effect is called the threshold dose. However, because of the relationship between concentration and time, there is no single threshold dose for an effect.

Reduction in yield, whether quantitative or qualitative, is also of prime importance but is difficult to measure. Foliar damage to root crops, for example, may bear no relationship to the amount of economic damage incurred. If injury occurs near harvest time, there may be no detectable yield loss (Capron and Mansfield, 1976).

**Figure 2 - Land Use and Vegetation Cover near Medicine Bow Project Site**  
(light yellow denotes cropland, darker green is forest, blue is water, light tan is fallow, dark tan is shrubland)



Distance Ring Radius is 10 km

### **Effects of NO<sub>x</sub>**

The direct effects of NO<sub>x</sub> on vegetation are usually associated with and confined to areas near specific industrial sources. For example, vegetation injury from exposure to high NO<sub>2</sub> concentrations has been observed near nitric acid factories and arsenals, but there is little published information regarding vegetation injury in the field due to NO or other NO<sub>x</sub> (U.S. EPA, 1982a).

Many reports, however, have substantiated NO<sub>x</sub> effects on vegetation grown in laboratory conditions (Hill and Bennett, 1970; Capron and Mansfield, 1976; Czeh and Nothdruff, 1951; Taylor et al., 1975; Kress, 1982). A threshold value of 191 µg/m<sup>3</sup> for long-term (10,000-hour) laboratory exposures of crops and trees has been widely used (U.S. EPA, 1982a). The maximum modeled NO<sub>x</sub> increase from Medicine Bow is low (2.40 µg/m<sup>3</sup> based on annual averaging) and well below the threshold value (191 µg/m<sup>3</sup>). Therefore, no detrimental effects on vegetation in the project area will likely result from NO<sub>x</sub> emissions from the Medicine Bow project.

### **Effects of SO<sub>2</sub>**

SO<sub>2</sub> enters the plant in gaseous form through openings in the plant's leaf surface called stomata. Once inside the leaf, SO<sub>2</sub> contacts wet, cellular membranes, and sulfites and sulfates may be formed. The formation of these compounds can cause changes in the plant's metabolic system that will produce physiological dysfunctions (U.S. EPA, 1982b).

Short-term (1-hour) peak SO<sub>2</sub> concentrations are particularly important when assessing potential vegetation impacts (Houston, 1974). Laboratory experiments have demonstrated greater relative toxicity of short-term exposures at high SO<sub>2</sub> concentrations than long-term exposures with the same total treatment (Zahn, 1970; McLaughlin et al., 1979; Sij, Kanemasu, and Goltz, 1974; Wilhour et al., 1978; Miller et al., 1979; Sprugel et al., 1980; Houston, 1974; Berry, 1972; Temple, 1972).

The maximum SO<sub>2</sub> concentration increase from the Medicine Bow project (1.08 µg/m<sup>3</sup> based on annual averaging) is far less than the lowest concentration of 240 µg/m<sup>3</sup> (Miller et al., 1979; Sprugel et al., 1980) that has been shown to reduce yield in the most sensitive agricultural crop, soybean, and the 390 µg/m<sup>3</sup> (Houston, 1974) forest species threshold.

### **Effects of PM/PM<sub>10</sub>**

Adverse impacts on vegetation from PM/PM<sub>10</sub> are most often associated with sustained accumulation of particles such as dust or fly ash on the leaf surface. Such particle accumulation on leaves can result in reduced gas exchange, increased leaf temperature, reduced photosynthesis, and eventual yellowing and tissue desiccation (Parish, 1910; Darley, 1966).



The maximum modeled PM/PM<sub>10</sub> impact from the Medicine Bow emission units is 7.41 µg/m<sup>3</sup> (24-hour average). At less than 5 percent of the secondary NAAQS, this increase in particulate concentration is not expected to cause plant injury.

#### REFERENCES

- Berry, C.R., 1972. "Relative sensitivity of red, jack, and white pine seedlings to ozone and sulfur dioxide." *Phytopathology* 68: 231-232.
- Capron, T.M., and T.A. Mansfield, 1976. "Inhibition of net photosynthesis in tomato in air polluted with NO and NO<sub>2</sub>." *J. Exp. Bot.* 27: 1181-1186.
- Czeh, M., and W. Nothdruff, 1951. "Investigations of the damage to field and horticultural crops by chlorine, nitrous and sulfur dioxide gases." *Landwirtschaft Forsch.* 4: 1-36.
- Darley, E.F., 1966. "Studies on the effect of cement-kiln dust on vegetation." *J. Air Pollut. Control Assoc.* 16: 145-150.
- Hill, A.C., and J.H. Bennett, 1970. "Inhibition of apparent photosynthesis by nitrogen oxides." *Atmos. Environ.* 4: 341-348.
- Houston, D.B., 1974. "Response of selected *Pinus strobus* clones to fumigation with sulfur dioxide and ozone." *Can. J. for Res.* 4: 65-68.
- Kress, L.W., 1982. "Response of several eastern forest tree species to chronic doses of ozone and nitrogen dioxide." *Plant Dis.* 66: 1149-1152.
- McLaughlin, S.B., D.S. Shriner, R.K. Mconthay, and L.K. Mann., 1979. "The effects of SO<sub>2</sub> dosage kinetics and exposure frequency on photosynthesis and transportation of kidney beans (*Phaseolus Vulgaris*)." *Environ. and Exp. Bot.* 19: 179-191.
- Miller, J.E., H.J. Smith, P.G. Sprugel, and P.B. Xerikos, 1979. "Yield Response of field-grown soybeans to an acute SO<sub>2</sub> exposure." *Radiol. Environ. Res. Div. Annu. Rep. Argonne National Laboratory, ANL-78-65, Part III.*
- Parish, S.B., 1910. "The effect of cement dust on citrus trees." *Plant World* 13: 288-291.
- Sij, J.W., E.T. Kanemasu, and S.M. Goltz, 1974. "Some preliminary results of sulfur dioxide effects on photosynthesis and yield in field-grown wheat." *Trans. Kans. Acad. Sci.* 76: 199-207.
- Smith, 1981. *Air Pollution and Forests*. School of Forestry and Environmental Studies, Yale University, New Haven, CT.

- Sprugel, D.G., J.E. Miller, R.N. Mueller, H.J. Smith, and P.B. Xerikos, 1980. "Sulfur dioxide effects on yield and seed quality in field-grown soybeans." *Phytopathology*. 70: 1129-33.
- Taylor, O.C., C.R. Thompson, O.T. Tingey, and R.A. Reinert, 1975. "Oxides of nitrogen." In: *Responses of Plants to Air Pollution*. J.B. Mudd and T.T. Kozlowski, eds. Academic Press, Inc., New York, NY. pp. 121-139.
- Temple, P.J., 1972. "Dose-response of urban trees to sulfur dioxide." *J. Air Pollut. Control Assoc.* 22: 271-274.
- U.S. EPA 1980. *A Screening Procedure for the Impact of Air Pollution Sources on Plants, Soils, and Animals*. EPA-450/2-81-078. December 1980.
- U.S. EPA, 1982a. *Air Quality Criteria for Oxides of Nitrogen*. U.S. EPA Publication No. EPA 600/8-82-026. September.
- U.S. EPA, 1982b. *Air Quality Criteria for Particulate Matter and Sulfur Oxides*. U.S. EPA Publication No. EPA 600/8-82-29c. December.
- Wilhour, R.G., A. Neely, D. Weber, and L. Grothaus, 1978: "The response of selected small grains and range grasses, and alfalfa to SO<sub>2</sub>." In: *Bioenvironmental Impact of a Coal-fired Power Plant*. E.M. Preston and T.L. Gallett, eds. U.S. EPA Publication No. EPA 600/3-79-044, U.S. Environmental Protection Agency, Corvallis Environmental Research Laboratory, Corvallis, Oregon. December. pp. 592-609.
- Zahn, R., 1970. "The effect on plants of a combination of subacute and toxic sulfur dioxide doses." *Staub*. 30: 20-23.

**Comment.** The March 5, 2007 letter also included item 7, which stated that the application should include a risk assessment for Hazardous Air Pollutants. Specifically, an applicant should conduct a Tier 1 risk assessment of HAPs to compare the chronic carcinogenic, chronic non-carcinogenic, and acute non-carcinogenic risks to the respective reference levels.

**Response.** The application included HAP emissions (Table 1.2 and Appendix B) that will be emitted primarily from the operation of the turbine sources. For example, of the 5.23 ton/year of HAP emissions cited, 4 tons are to be emitted from the turbines (76 percent of total HAP emissions). Applying the turbine-specific emitted HAP impacts to the EPA IRIS levels - Carcinogenic Risk from Inhalation Exposure (CIR 1e-6) or Reference Concentration for Chronic Inhalation Exposure (RfC) demonstrates that the HAP exposure from the facility should be much less than these thresholds and therefore HAP impacts are likely very minor. The results of this comparison are shown in Table 2.

**Table 2. Medicine Bow – Modeled HAP Concentrations Compared with EPA IRIS Threshold Levels**

HAP	Modeled Concentration ( $\mu\text{g}/\text{m}^3$ )	EPA IRIS Threshold Level ( $\mu\text{g}/\text{m}^3$ )	Reference Level
1,3-Butadiene	3.75E-06	0.03	CIR 1e-6
Acetaldehyde	0.000349	0.5	CIR 1e-6
Acrolein	5.58E-05	N/A	N/A
Benzene	0.000105	0.13	CIR 1e-6
Formaldehyde	0.000619	0.08	CIR 1e-6
Mercury	0.001487	0.3	RfC
Naphthalene	1.13E-05	3	RfC
Toluene	0.001133	5000	RfC
Xylene	0.000558	100	RfC

source: <http://www.epa.gov/iris/subst/>

**Comment.** Section 6.6.5 (Discussion of Results) – The applicant describes the results of the preliminary (significance) modeling and that the black start generators contribute primarily to the maximum predicted impacts. Later, the applicant states that “Normal operations at the facility will not include the black start generator emissions and therefore the impacts will be lowered”. The Division has two comments on this: 1) black start generators and other equipment that will be used for start-up should not be included in the preliminary modeling that determines the need for full-impact (WAAQS and PSD increment) modeling, and 2) it is not sufficient to merely speculate on the magnitude of the modeled impacts from normal operation of the facility.

**Response.** Additional AERMOD modeling was conducted based on normal operations that excluded black start generator operations and emissions. Results indicated that significance levels were exceeded. Consequently, full-impact (WAAQS and PSD increment) modeling continues to be required and has been conducted.

**Comment.** Tables 6.9 through 6.12 in the application indicate that the results of preliminary modeling exceed Class II area modeling significance levels for all modeled criteria pollutants. This would require further analysis to insure that ambient air quality standards and PSD increments are protected, but no further analysis was provided. The applicant should perform full-impact modeling and submit revised modeling files and documentation to the Division, or the applicant should revise the preliminary modeling to reflect changes to the project configuration that would result in modeled impacts that are below the significance levels.

**Response.** Medicine Bow believed at the time of the application that no other emission units were located within the significant impact area of the proposed Medicine Bow facility; therefore, only Medicine Bow facility emissions were modeled based on the belief that this accounted for all reasonable impacts in the immediate area.

Medicine Bow contacted the AQD and understands that only tailpipe emissions associated with the Carbon mine operations need to be included in the off-site emission inventory for cumulative modeling. Therefore, Medicine Bow has conservatively modeled the tailpipe emissions as area source emissions. The results of the updated modeling are shown in Tables 6.13 through 6.16 below. These tables include modeled concentrations for aggregated Medicine Bow and cumulative inventory impacts. Aggregate impacts demonstrate compliance with the NAAQS.

## **2. AERMOD Files Submitted on CD**

**Comment.** The CD containing AERMOD files did not include the surface files for Rawlins, WY or the upper air files for Riverton, WY that were used in the Stage 1 AERMET processing.

**Response.** The files are attached as "medicine bow rawlins surface data.zip" and "medicine bow upper air data.zip" files.

**Comment.** The CD containing AERMOD files did not include any BPIP input/output or AERMAP input/output files.

**Response.** The files are attached as "medicine bow aermap and bpip files.zip" files.

**Table 6.13 - Medicine Bow - Maximum Predicted SO<sub>2</sub> Concentrations from the Proposed Project and Off-site Inventory Tailpipes for Comparison with the WAAQS**

Averaging Period	Data Period			Receptor Location (m)		Maximum Predicted Concentration (µg/m <sup>3</sup> )	WAAQS (µg/m <sup>3</sup> )
	Year	Month/Day	Hour Ending	East	North		
Annual	2000	--	--	391800	4624400	0.88	60
	2001	--	--	391600	4624300	1.27	
	2003	--	--	391465	4624330	1.29	
	2004	--	--	391500	4624200	1.09	
	2005	--	--	391600	4624200	1.05	
24-Hour Highest	2000	09/28	24	392000	4622000	12.02	260
	2001	02/26	24	389700	4621700	12.77	
	2003	02/13	24	390400	4621800	11.26	
	2004	02/11	24	391055	4623190	8.99	
	2005	10/25	24	390300	4622000	10.94	
3-Hour Highest	2000	09/28	03	392000	4622000	71.53	1300
	2001	01/08	21	389700	4621700	68.18	
	2003	02/28	06	390400	4621900	67.61	
	2004	09/06	24	390649	4623190	70.56	
	2005	12/07	03	390649	4623190	80.31	

**Table 6.14 – Medicine Bow - Maximum Predicted PM/PM<sub>10</sub> Concentrations from the Proposed Project and Off-site Inventory Tailpipes for Comparison with the WAAQS**

Averaging Period	Data Period			Receptor Location (m)		Maximum Predicted Concentration (µg/m <sup>3</sup> )	WAAQS (µg/m <sup>3</sup> )
	Year	Month/Day	Hour Ending	East	North		
Annual	2000	--	--	391460	4623780	42.11	50
	2001	--	--	390649	4623190	17.77	
	2003	--	--	391461	4623880	31.75	
	2004	--	--	391459	4623630	32.76	
	2005	--	--	391459	4623630	34.64	
24-Hour Highest	2000	09/28	24	392000	4622000	12.02	150
	2001	02/26	24	389700	4621700	12.77	
	2003	02/13	24	390400	4621800	11.26	
	2004	02/11	24	391055	4623190	8.99	
	2005	10/25	24	390300	4622000	10.94	

Annual values include fugitive mine emissions from open pit mining operations as modeled from an area source as requested by AQD.

**Table 6.15 – Medicine Bow - Maximum Predicted CO Concentrations from the Proposed Project and Off-site Inventory Tailpipes for Comparison with the WAAQS**

Averaging Period	Data Period			Receptor Location (m)		Maximum Predicted Concentration ( $\mu\text{g}/\text{m}^3$ )	WAAQS ( $\mu\text{g}/\text{m}^3$ )
	Year	Month/Day	Hour Ending	East	North		
1-Hour Highest	2000	09/28	02	390855	4623190	6415.1	40000
	2001	01/09	08	391462	4623930	7565.5	
	2003	09/05	05	390705	4623190	8957.3	
	2004	09/06	22	390649	4623190	9150.7	
	2005	14/07	01	390649	4623190	11224.2	
8-Hour Highest	2000	09/28	08	390805	4623190	1583.0	10000
	2001	11/08	24	391462	4623980	1317.5	
	2003	01/17	24	391462	4623980	1555.3	
	2004	01/16	24	391462	4623980	1577.0	
	2005	12/07	08	390649	4623190	1682.6	

**Table 6.16 – Medicine Bow - Maximum Predicted NO<sub>x</sub> Concentrations from the Proposed Project and Off-Site Inventory Tailpipes for Comparison with the WAAQS**

Averaging Period	Data Period			Receptor Location (m)		Maximum Predicted Concentration (µg/m <sup>3</sup> )	WAAQS (µg/m <sup>3</sup> )
	Year	Month/Day	Hour Ending	East	North		
Annual	2000	--	--	391460	4623780	39.77	100
	2001	--	--	391460	4623780	34.16	
	2003	--	--	391462	4623980	27.38	
	2004	--	--	391459	4623630	26.95	
	2005	--	--	391459	4623580	28.85	



**Comment.** An initial inspection of the AERMOD files for PM10 shows that the sources associated with the adjacent mine (COALSTOR, 2014pit, etc.) are assigned emission rates of zero. As described in the Division's March 5, 2007 letter, fugitive sources from the mine should be included in the PM10 modeling for the annual averaging period. Please provide revised modeling that reflects the emissions from the mine or an explanation of the emissions shown in the submitted modeling files. [Note: Any revision to the AERMOD runs should use the base elevation of the meteorological tower as input for the PROFBASE variable which is used to specify the based elevation (above MSL) for the potential temperature profile generated by AERMOD for use in plume rise calculations. The submitted AERMOD files used 0 meters and 2 meters as input for PROFBASE. Also, and revision to the AERMOD runs that includes the use of the open pit source type should include documentation that fully explains the choice of particle deposition values (mass fractions, particle diameters, etc.)].

**Response.** Emissions from the pit sources were inadvertently left out of the annual runs requested by AQD. The annual runs have been updated (Table 6.14 above) to include fugitive emissions from the mine as well as the coal storage area. The areapoly source was used rather than the open pit source and therefore no deposition algorithms were invoked. The PROFBASE was corrected to reflect the tower base elevation.

## **Far-Field (CALPUFF) Impact Analysis**

### **1. CALMET Files on DVD**

**Comment.** An examination of the terrain and landuse output files shows that both include blocks of missing data (see figure below showing terrain for the modeling domain). The applicant should obtain complete data for the domain, revise the MAKEGO portion of the CALMET processing and submit the revised input/output files to the Division. [graphic has been deleted]

**Response.** The files are included within the MAKEGEO file folder.

### **2. Section 7: Far-Field Air Quality Impact Analysis**

**Comment.** The letter from the Division dated March 5, 2007 provided comments on the CALPUFF protocol, including item B.6 which requested an analysis of the final CALMET wind field: *"At a minimum, the analysis should include an examination of the wind flows for selected times and vertical layers. The flows produced by CALMET should be compared to observed flows as seen in archived weather maps and/or compared to expected flows (e.g., downslope winds during stable conditions at night). Other parameters such as precipitation can also be compared to observed conditions."* No analysis was provided with the application.

**Response.** After running CALMET, the resulting data fields were analyzed using the PRTMET utility to illustrate the assimilated wind and temperature fields within the domain for quality assurance purposes. PRTMET enables the user to extract meteorological data fields such as wind speed and direction, temperature, and mixing height on an hourly "snapshot" or average basis.

Part of the quality assurance process determined whether wind patterns were influenced by terrain; this is a good indication of whether meteorological data is properly located relative to the terrain. Figure 3 shows area contours, with pink shaded areas representing high terrain. PRTMET quality assurance graphics are included in Figures 4 through 11 for an approximate 10 km grid to demonstrate that the selection of CALMET control options resulted in a reasonable simulation of the meteorology within the domain. Particularly good instances of terrain influenced flow can be seen in Figure 4 (March 19, 2003 – hour 3) at the following locations:

East -220, North -200  
East -220, North -20  
East 150, North 150  
East 75, North 0

Another good example of terrain influenced flow can be seen in Figure 8 (June 19, 2003 – hour 3) at the following locations:

East -275, North 75  
East 50, North -125  
East 75, North 0  
East -275, North -25

The time for one of the hourly wind field vector snapshots was chosen based on the worst visibility impairment day from CALPUFF modeling. The largest extinction change occurred at the Savage Run sensitive Class II area on March 19, 2003. Meteorological conditions on March 19, 2003 were unusual due to a major winter storm. Attachment 7 [Appendix O] includes "Mesoscale Model Simulations in Quasi-Forecast Mode of the Great Western Storm of 16-20 March 2003." This document summarizes meteorological conditions during that time. The document is also available on the CD-ROM as "Meso\_Model\_Great\_Storm\_2004.pdf."

Since March 19<sup>th</sup> conditions represent winds flowing toward Class I areas in Colorado, the other snapshot was chosen based on the worst visibility impairment day for Class I areas in Wyoming such as the Bridger Wilderness area and the Fitzpatrick Wilderness area. The largest extinction change in both Class I areas in Wyoming occurred on June 19, 2003.

These snapshot days also represent one day for summer (June 19, 2003) and one day for winter (March 19, 2003). Two hours on each day were plotted: 0300 Mountain Standard Time (MST) and 1500 MST. Furthermore, for each time period, a surface wind field, corresponding to Level 1, and an upper air wind field, corresponding to Level 8, was plotted. Plots developed in this study are shown in Table 3. These wind fields appeared to accurately capture terrain, slope, and seasonal effects expected within the modeling domain, and demonstrated generally smooth translations and continuous Mesoscale flow. These characteristics validated the spatial behavior of the meteorological data set throughout the modeling domain.

**Table 3 - List of Wind Vector Plots**

Date	March 19, 2003	June 19, 2003
Hour	3,15	3,15
Vertical layer	1,8	1,8

Windroses from the CALMET model output and the surface observation station data sets indicated general agreement in wind directions, frequencies, and speeds. Windroses for March 2003 from several surface observation stations such as Aspen, Laramie General Brees Field (Laramie), Craig-Moffat stations were plotted and are shown in Figures 13 through 15. The locations of the selected stations are shown in the Figure 12. The list of windroses developed in this study is included in Table 4. Windrose plots from surface observation stations and the CALMET-predicted output are shown in Figures 13 through 15 and indicate good agreement between surface observations and CALMET predicted output.

**Table 4 - List of Windroses (March 1 - March 31, 2003)**

Station Name	Data Period (Total Count) March 1 - March 31, 2003		Location of the Station	
	Observation	CALMET-Predicted	Observation (Latitude, Longitude)	CALMET-Predicted (Grid Cell)
Aspen	672 hours	743 hours	39.217N, 106.867W	93, 12
Laramie	715 hours	743 hours	41.313N, 105.674W	118, 71
Craig-Moffat	684 hours	743 hours	40.5N, 107.533W	79, 48

Figure 3 - 3-D Terrain Elevation Contours

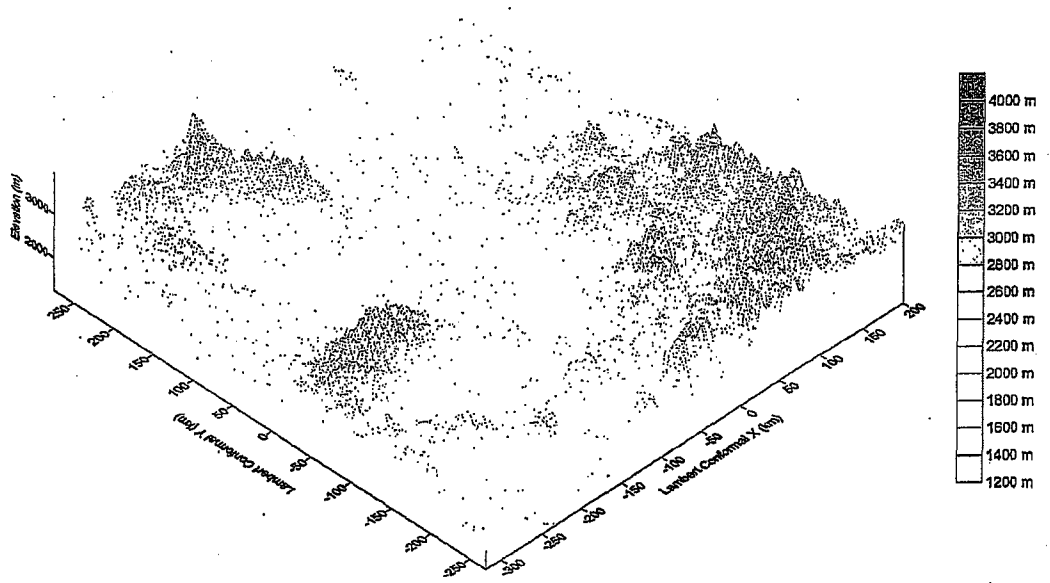
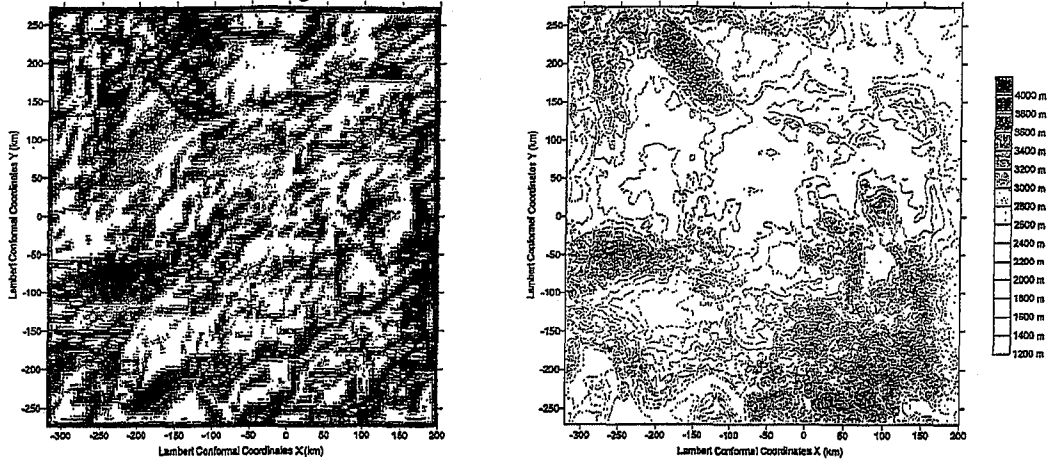


Figure 4 - Surface Air Windfield March 19, 2003, Hour 3, Layer 1

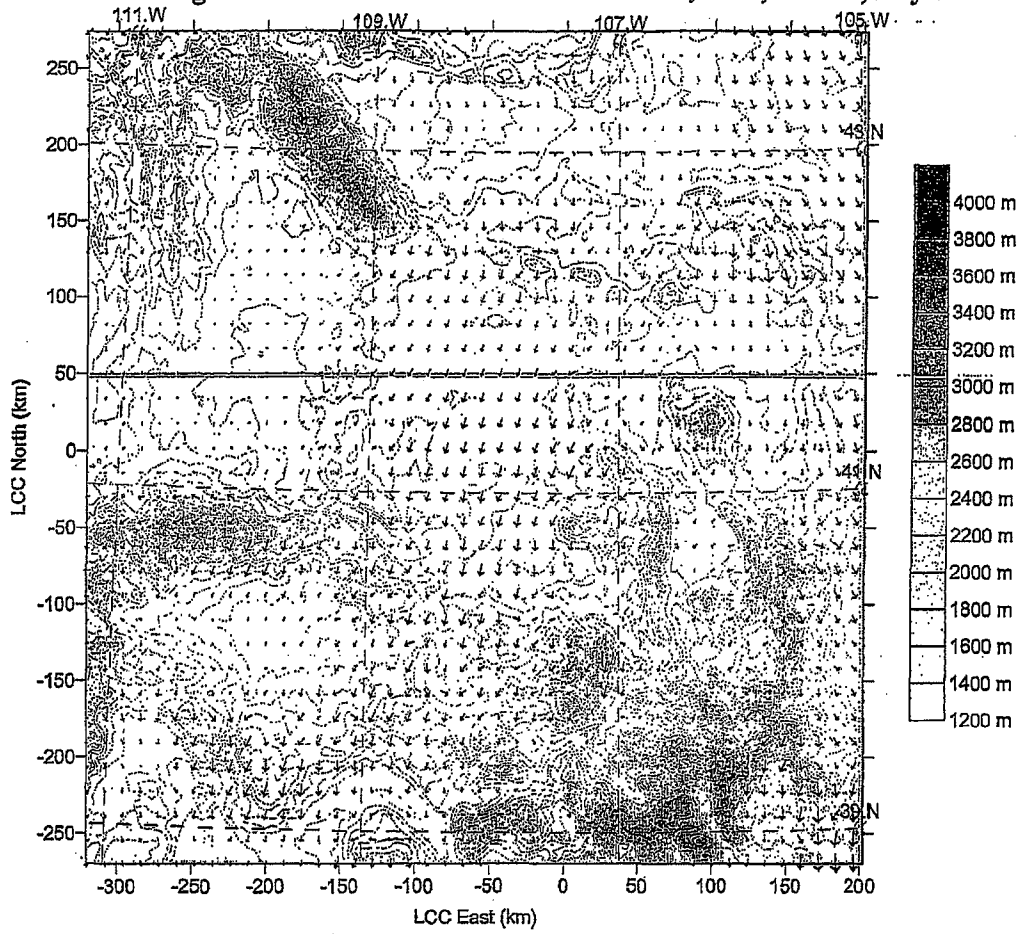


Figure 5 - Surface Air Windfield March 19, 2003, Hour 15, Layer 1

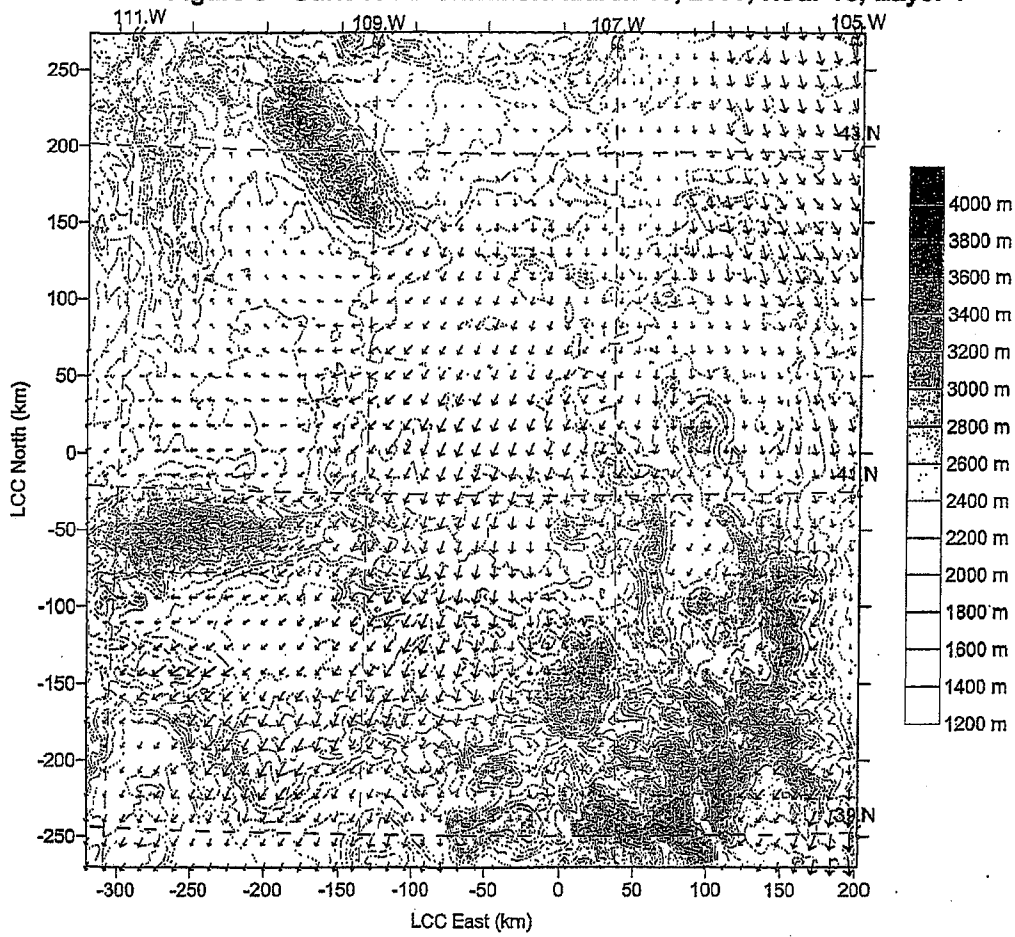
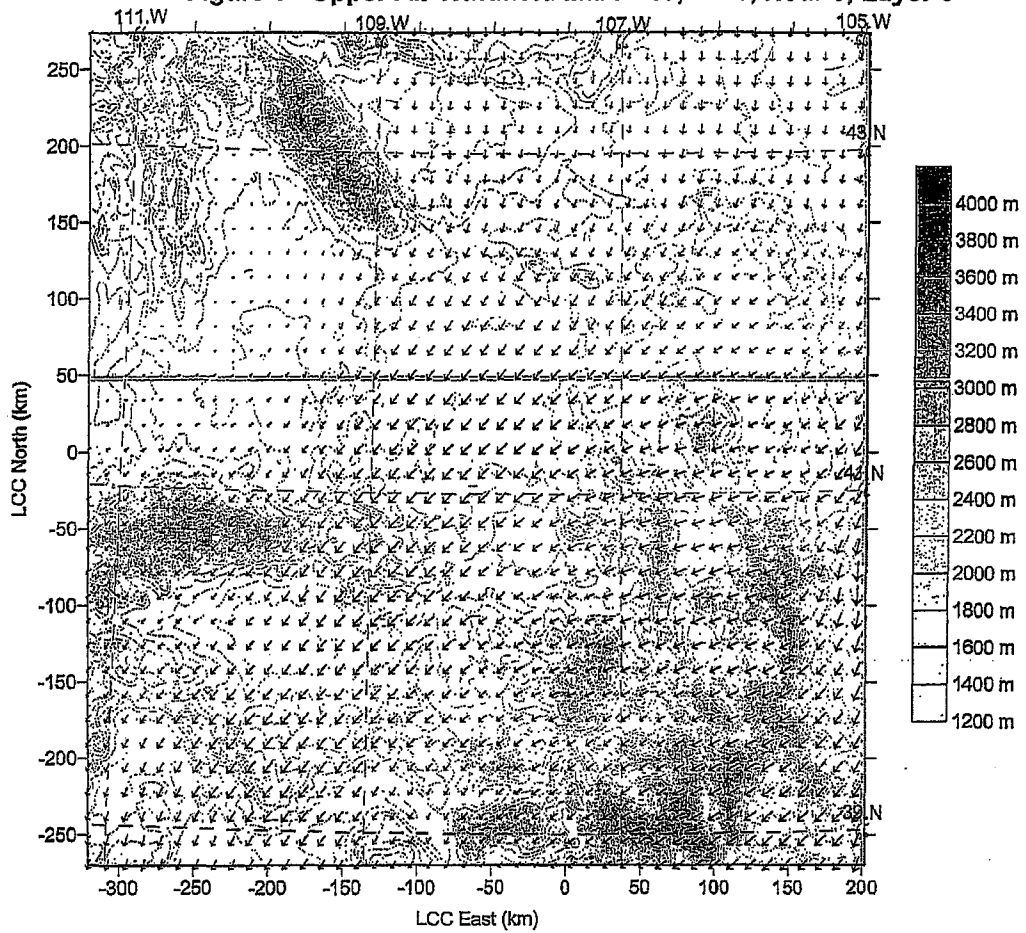


Figure 6 - Upper Air Windfield March 19, 2003, Hour 3, Layer 8



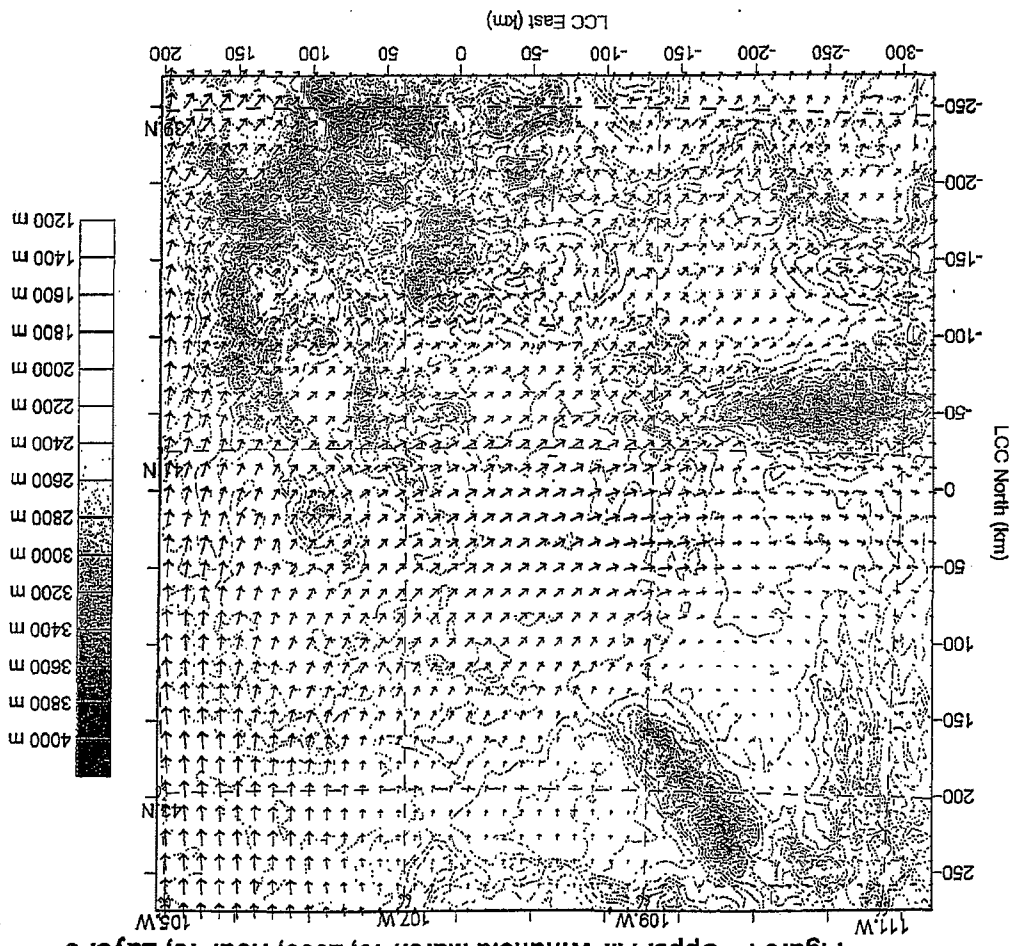


Figure 7 - Upper Air Windfield March 19, 2003, Hour 15, Layer 8



Figure 8 - Surface Air Windfield June 19, 2003, Hour 3, Layer 1

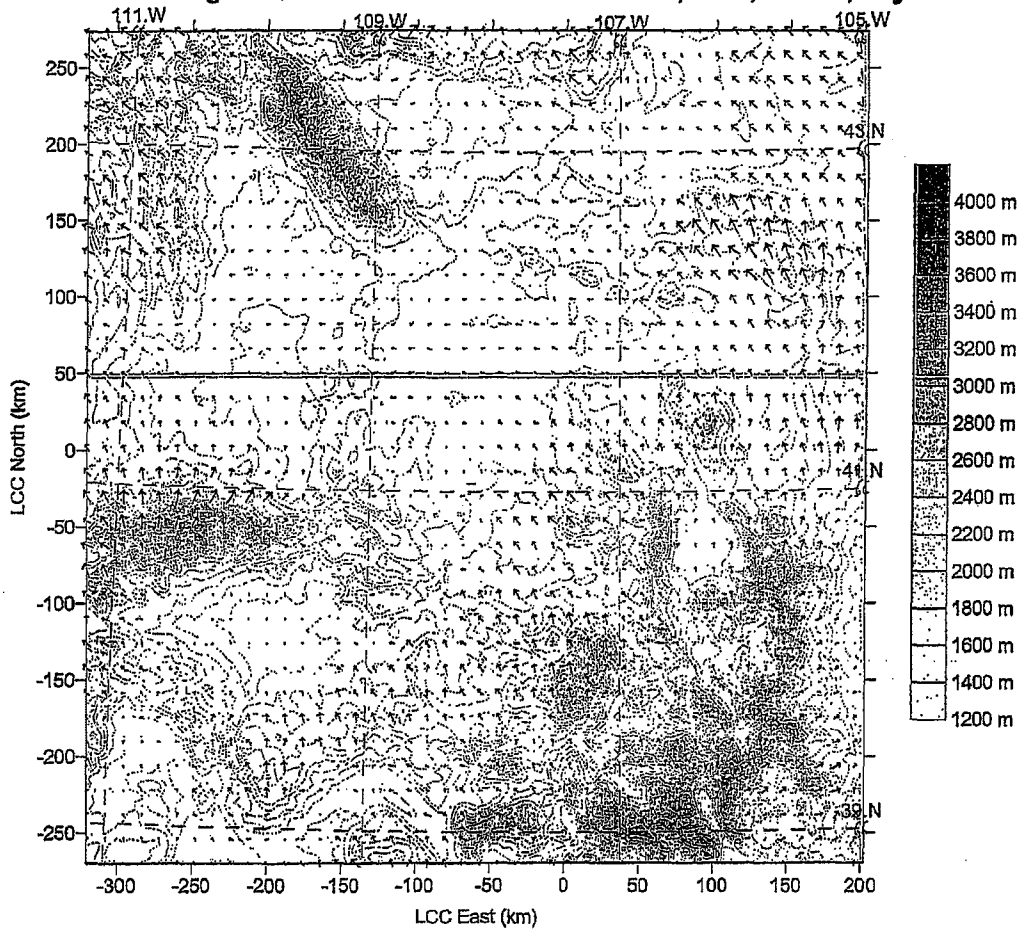


Figure 9 - Surface Air Windfield June 19, 2003, Hour 15, Layer 1

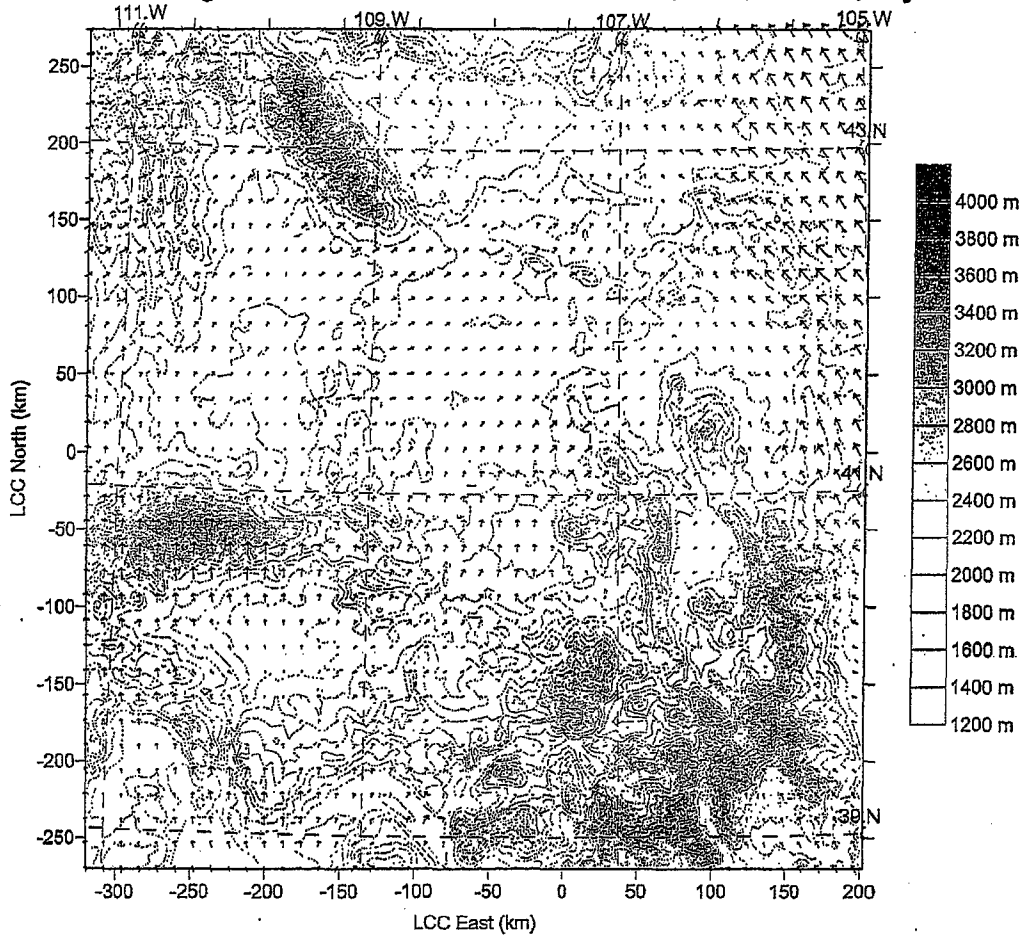


Figure 10 - Upper Air Windfield June 19, 2003, Hour 3, Layer 8

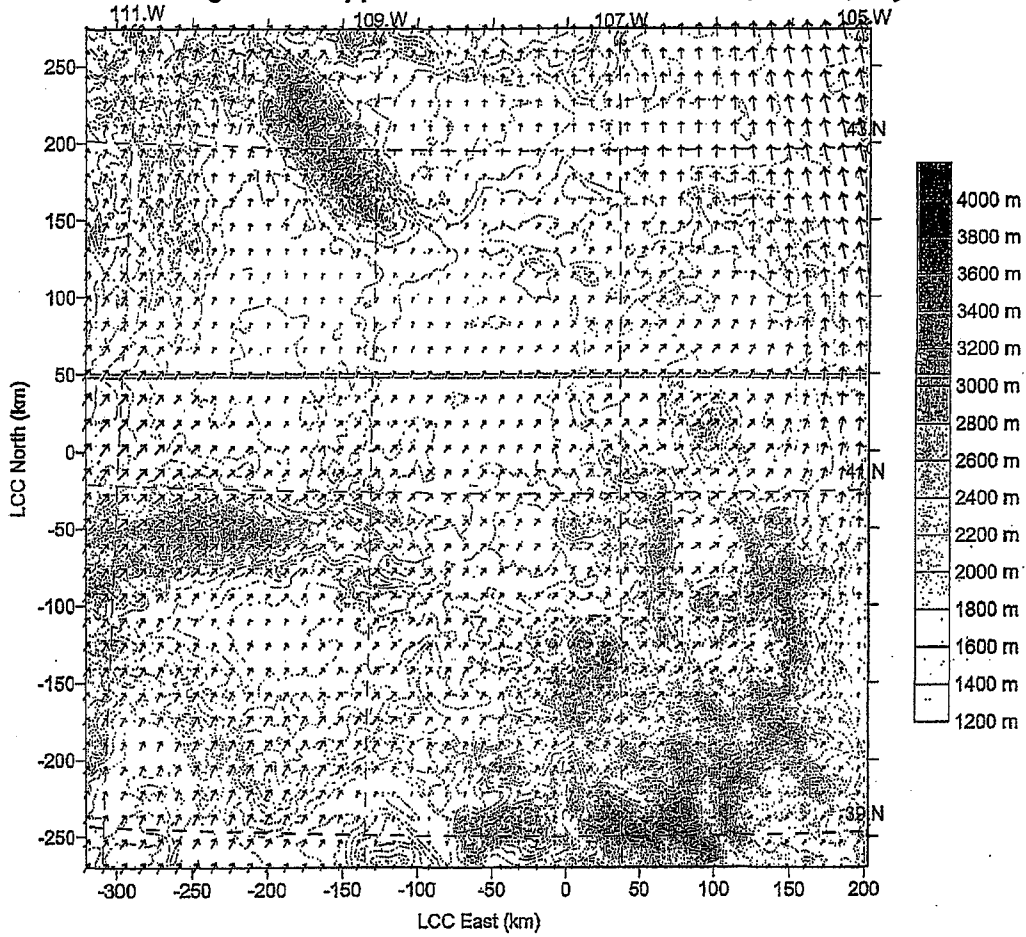


Figure 11 - Upper Air Windfield June 19, 2003, Hour 15, Layer 8

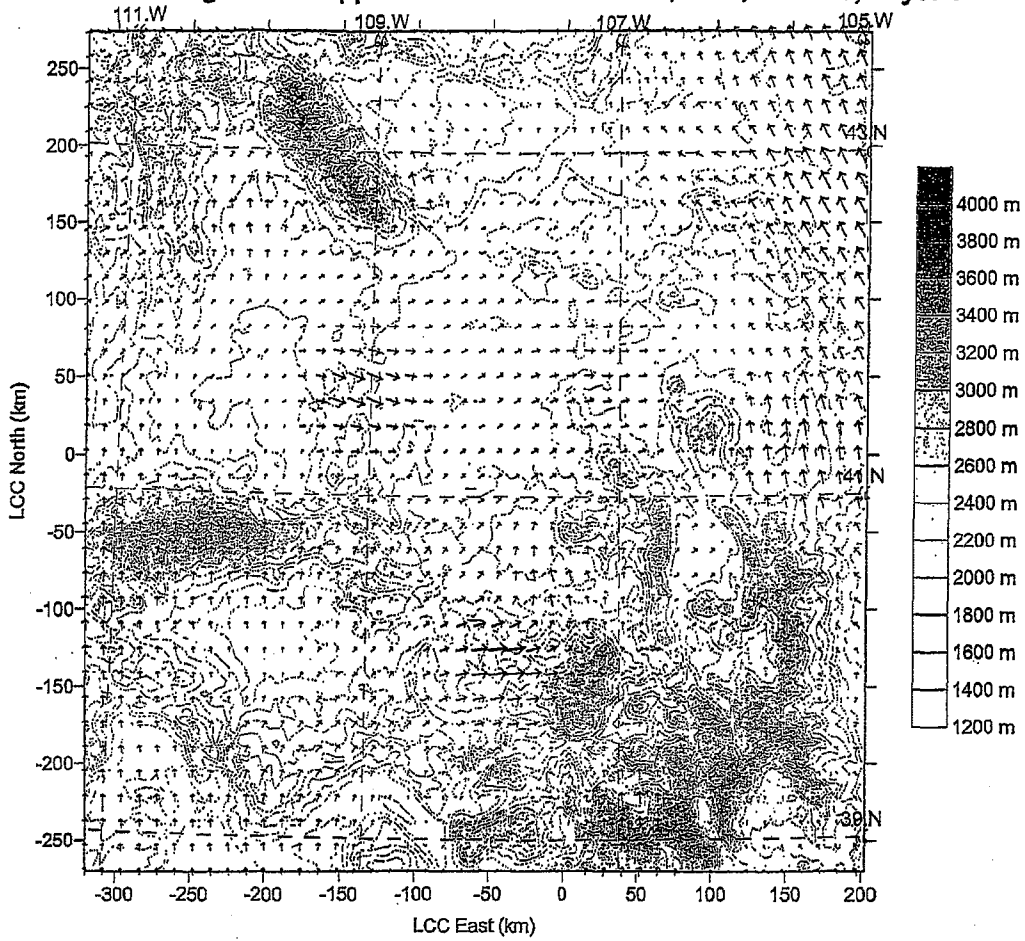


Figure 12 - Location of Selected Surface Observation Stations

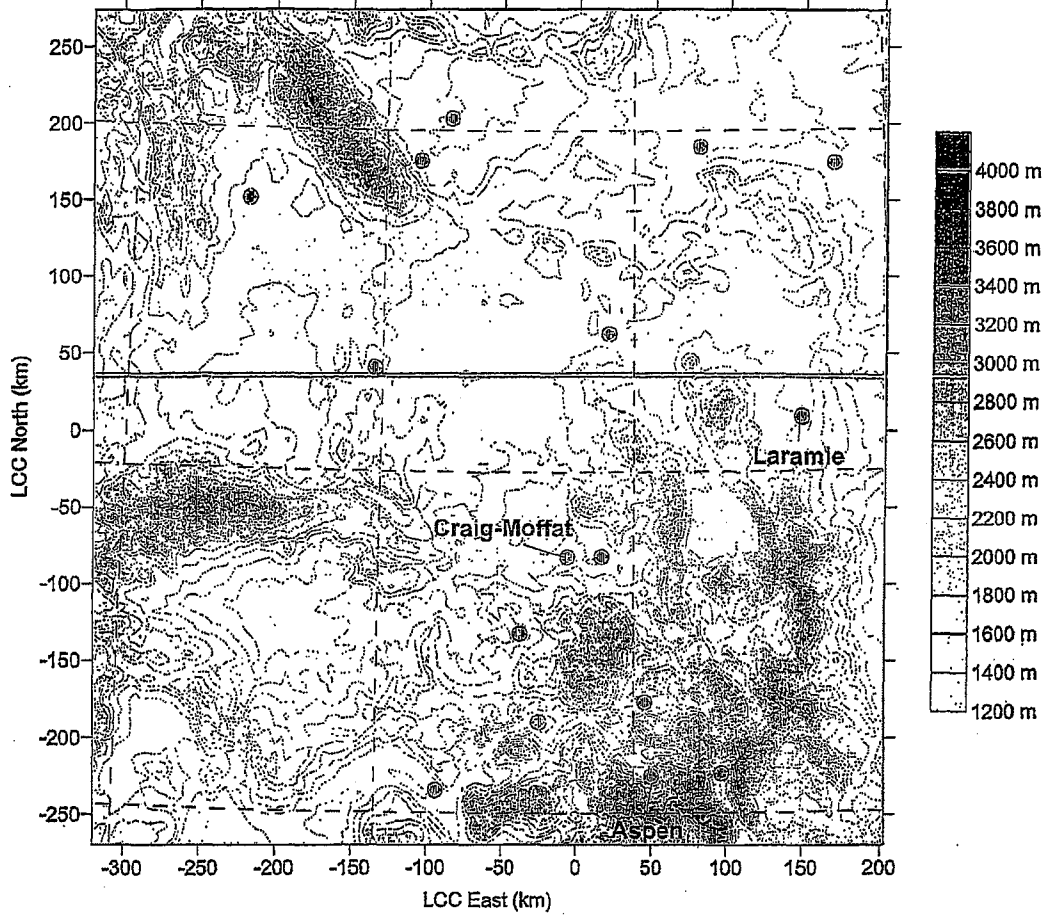
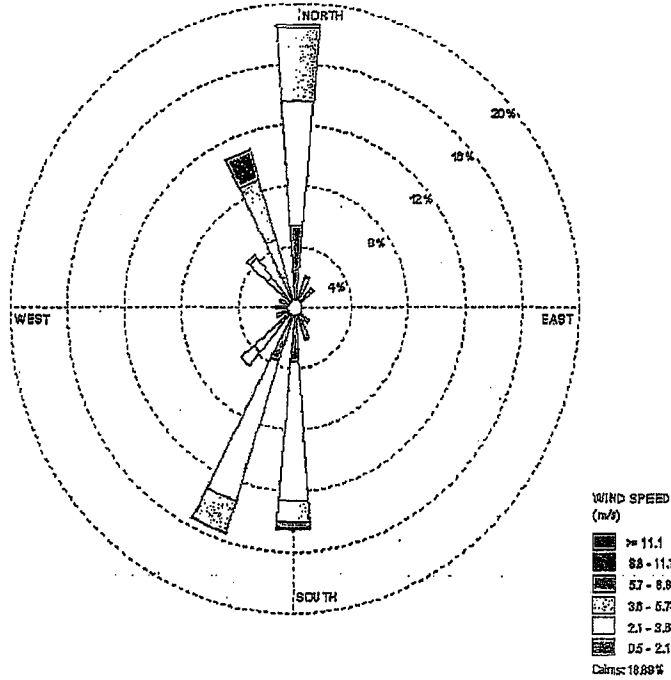


Figure 13 - Aspen field Windroses (March, 2003)

Aspen Field Observation Station Windrose -672 hours



Aspen Field CALMET-predicted Windrose (grid cell:93, 12)-743 hours

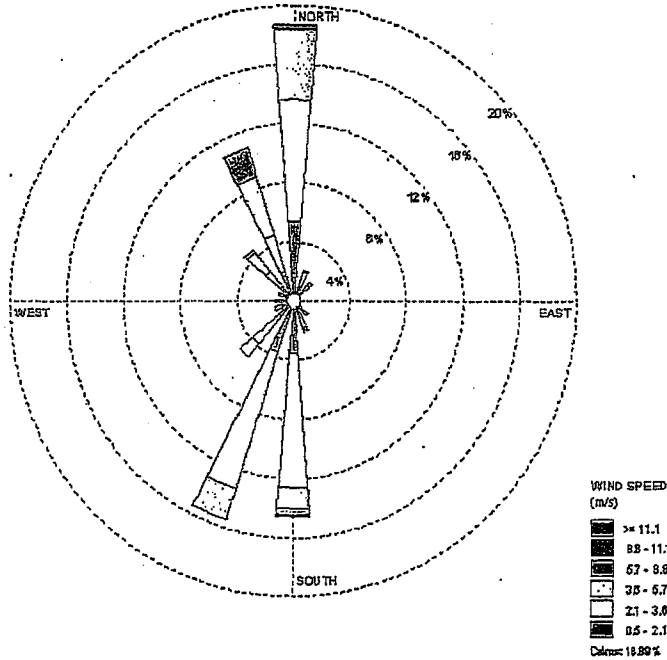
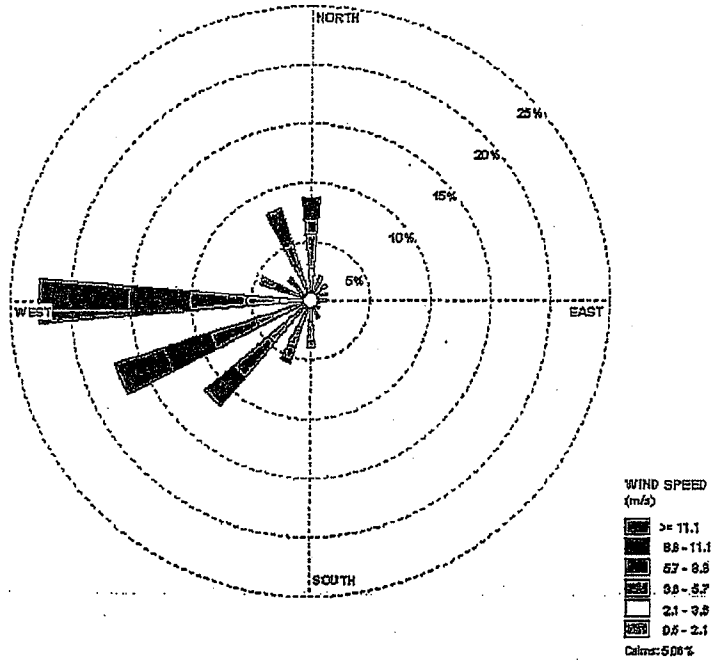
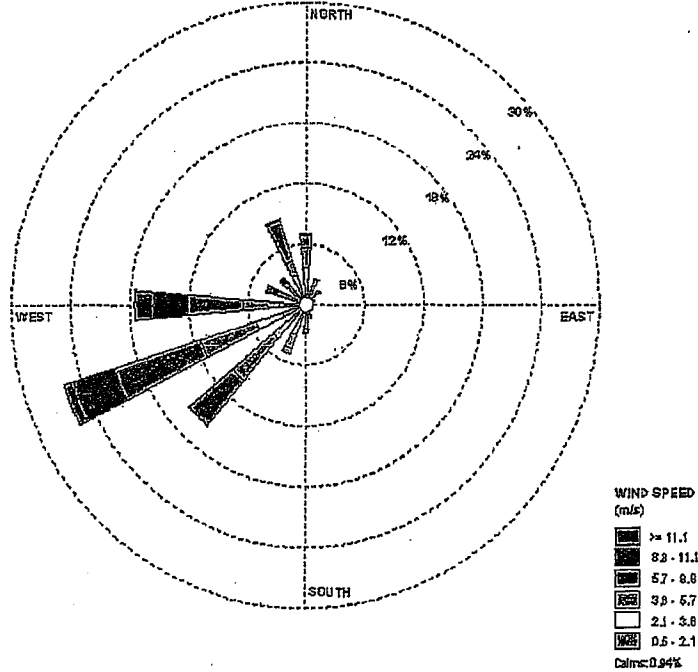


Figure 14 - Laramie field Windroses (March, 2003)

Laramie Field Observation Station Windrose-715 hours

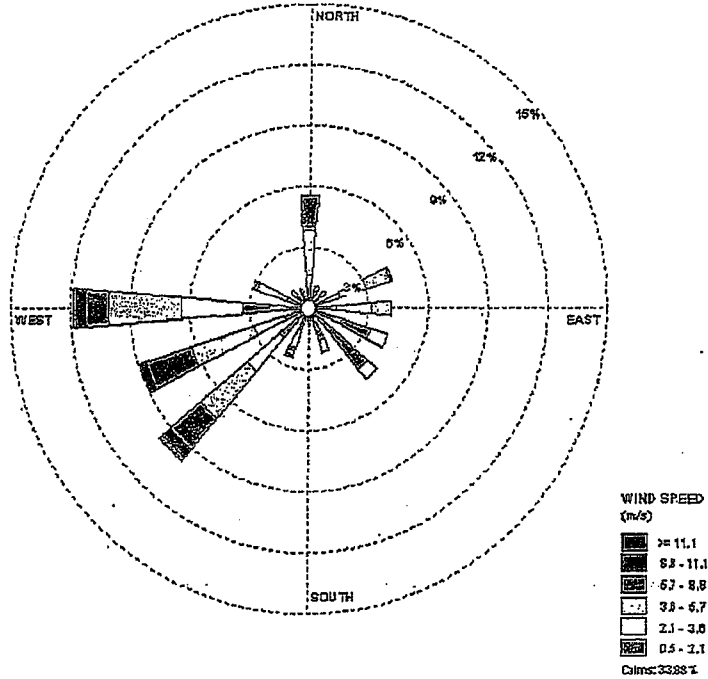


Laramie Field CALMET-predicted Windrose (grid cell:118, 71)-743 hours

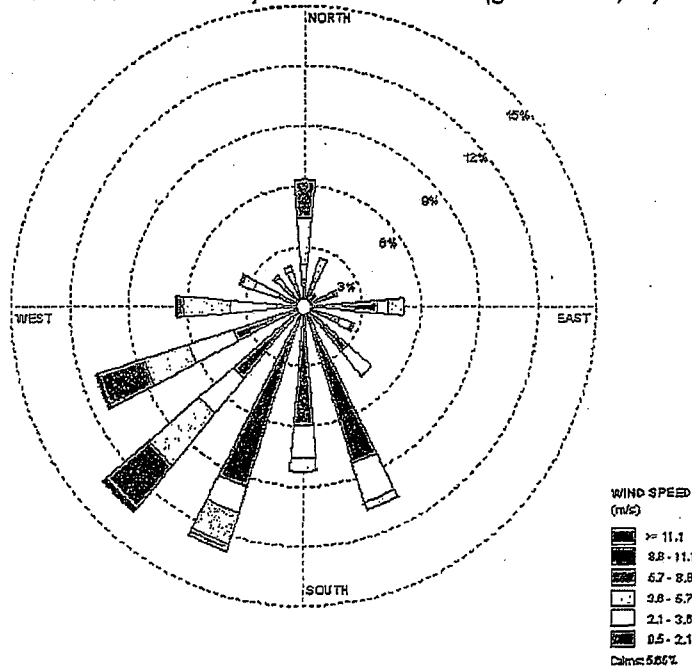


**Figure 15 - Laramie field Windroses (March, 2003)**

*Craig-Moffat Field Observation Station Windrose-684 hours*



*Craig-Moffat Field CALMET-predicted Windrose (grid cell:79,48)-743 hours*





**Appendix K**  
**NRCS Irrigated and Nonirrigated Yields by Map Unit**  
**for Carbon County, Wyoming**

DEQ 000399

# Irrigated and Nonirrigated Yields by Map Unit

Carbon County Area, Wyoming

Map symbol and soil name	Land capability		Alfalfa hay		Grass hay		Pasture	
	N	I	N	I	N	I	N	I
			Tons	Tons	Tons	Tons	AUM	AUM
4: Canburn	4w	4w	—	—	—	—	—	—
8: Gerrard	6w	6w	—	1.00	—	1.00	—	—
9: Grieves variant	4w	3w	—	—	—	—	—	—
9H: Grieves variant, alkali	4w	4w	—	—	—	—	—	—
13: Rhoamett	6e	4s	—	3.50	—	3.50	—	—
15A: Poposhia	4e	3e	—	3.00	—	3.00	—	4.0
15B: Poposhia	4e	3e	—	3.00	—	3.00	—	4.0
18A: Alcova	4e	3e	—	—	—	—	—	—
18B: Alcova	4e	3e	—	—	—	—	—	—
18C: Alcova	4e	4e	—	—	—	2.50	—	5.0
18H: Alcova, saline	6e	4e	—	—	—	3.50	—	7.0
20: Debone	7s	4s	—	—	—	—	—	—
22: Edlin	4e	3e	—	3.50	—	3.50	—	5.0
29: Canburn variant	4w	4w	—	—	—	—	—	—
31A: Tisworth	6s	4s	—	—	—	—	—	—

# Irrigated and Nonirrigated Yields by Map Unit

Carbon County Area, Wyoming

Map symbol and soil name	Land capability		Alfalfa hay		Grass hay		Pasture	
	N	I	N	I	N	I	N	I
			Tons	Tons	Tons	Tons	AUM	AUM
31B: Tisworth	6s	4s	---	---	---	---	---	---
34: Tresano	6e	6e	---	---	---	---	---	---
38A: Rock River	4e	3e	---	---	---	3.00	---	4.5
38B: Rock River	4e	3e	---	---	---	3.00	---	4.5
38C: Rock River	4e	4e	---	---	---	2.00	---	3.5
38H: Rock River, saline	6s	4s	---	---	---	3.00	---	4.5
40: Fiveoh	4e	6e	---	---	---	---	---	---
40H: Fiveoh, saline	6e	4s	---	---	---	---	---	---
43B: Grieves	4e	3e	---	3.00	---	2.00	---	5.0
45: Yetull variant	4e	6e	---	---	---	---	---	---
49: Firth variant	4w	3w	2.00	4.00	1.00	3.00	---	---
51W: Patent variant	4w	4w	---	---	---	---	---	---
52: Laney	6s	4s	---	2.00	---	---	---	---
52S: Laney variant Silckspots	6s 8	4s 8	---	---	---	---	---	---
53A: Pinelli	4e	3e	---	---	---	---	---	---

# Irrigated and Nonirrigated Yields by Map Unit

Carbon County Area, Wyoming

Map symbol and soil name	Land capability		Alfalfa hay		Grass hay		Pasture	
	N	I	N	I	N	I	N	I
			Tons	Tons	Tons	Tons	AUM	AUM
59: Absher variant	6s	4s	---	---	---	---	---	---
69: Kiltabar	4s	4s	---	---	---	---	---	---
78A: Ryan Park	4e	3e	---	---	---	3.00	---	4.0
78B: Ryan Park	4e	3e	---	---	---	3.00	---	4.0
79D: Blackhall	7e	7e	---	---	---	---	---	---
86: Ansel	6e	6e	---	---	---	---	---	---
101: Echemoor Clayburn	6e 6e	4e 4e	---	---	---	---	---	---
102: Echemoor Inchau	6e 7e	4e 6e	---	---	---	---	---	---
105: Starman Barrett	7e 7e	7e 7e	---	---	---	---	---	---
107: Starman Vabem	7e 7e	7e 7e	---	---	---	---	---	---
108: Lymanson Yauga	6e 6e	6e 4e	---	---	---	---	---	---
109: Lymanson Roxal	6e 7e	4e 6e	---	---	---	---	---	---
111: Vabem Inchau	7e 6e	7e 6e	---	---	---	---	---	---

# Irrigated and Nonirrigated Yields by Map Unit

Carbon County Area, Wyoming

Map symbol and soil name	Land capability		Alfalfa hay		Grass hay		Pasture	
	N	I	N	I	N	I	N	I
			Tons	Tons	Tons	Tons	AUM	AUM
118A:			---	---	---	3.50	---	7.0
Alcova	4e	3e						
Rock River	4e	3e						
118B:			---	---	---	3.00	---	6.0
Alcova	4e	3e						
Rock River	4e	3e						
128:			---	---	---	---	---	---
McFadden	6e	4e						
Brownsto	6e	4e						
Blackhall	7e	7e						
135B:			---	3.50	---	3.50	---	7.0
Cushool	6e	4e						
138A:			---	---	---	---	---	---
Rawlins	4e	3e						
Bosler	4e	3e						
138B:			---	---	---	---	---	---
Rawlins	4e	3e						
Bosler	4e	3e						
140:			---	---	---	---	---	---
Tisworth	6s	4s						
Poposhia	4e	3e						
141:			---	4.00	---	4.00	---	7.0
McFadden	6e	4e						
Brownsto	6s	4s						
144:			---	3.00	---	3.00	---	5.0
McFadden	6e	4e						
Blackhall	7e	6e						
147:			---	---	---	---	---	---
Rogert	7s	6e						
Quander	7s	6e						
Rock outcrop	8	8						
200:			---	---	---	---	---	---
Patent variant	4w	4w						
Hagga	4w	4w						

# Irrigated and Nonirrigated Yields by Map Unit

Carbon County Area, Wyoming

Map symbol and soil name	Land capability		Alfalfa hay		Grass hay		Pasture	
	N	I	N	I	N	I	N	I
			Tons	Tons	Tons	Tons	AUM	AUM
208:			—	—	—	—	—	—
Pinelli	6e	4e						
Forelle	6e	4e						
209:			—	—	—	—	—	—
Chaperton	6e	4e						
Boettcher	6e	4e						
210:			—	—	—	—	—	—
Absher variant	6s	4s						
217:			—	—	—	—	—	—
Dahlquist	6s	4s						
Cragosen	7s	6s						
218A:			—	—	—	3.50	—	7.0
Alcova	6e	3e						
Rawlins	6e	3e						
18B:			—	—	—	3.00	—	6.0
Alcova	6e	3e						
Rawlins	6e	3e						
221:			—	—	—	—	—	—
Blazon	7e	6s						
Chaperton	6e	4s						
224A:			—	4.00	—	4.00	—	7.0
McFadden	6e	3e						
Brownsto	6s	4s						
224B:			—	3.50	—	3.50	—	6.0
McFadden	6e	3e						
Brownsto	6s	4s						
224w:			—	4.00	—	4.00	—	7.0
McFadden, wet	6w	3w						
Brownsto, wet	6w	4w						
225:			—	3.00	—	3.00	—	7.0
Cushool	6e	4s						
Rock River	4e	3e						

# Irrigated and Nonirrigated Yields by Map Unit

Carbon County Area, Wyoming

Map symbol and soil name	Land capability		Alfalfa hay		Grass hay		Pasture	
	N	I	N	I	N	I	N	I
			Tons	Tons	Tons	Tons	AUM	AUM
229:			---	3.50	---	3.50	---	7.0
Cushool	6e	4s						
Cushool variant	6e	4s						
235:			---	---	---	---	---	---
Blazon	7e	6e						
Blazon, THIN SOLUM	7e	6e						
236:			---	---	---	---	---	---
Cushool	6e	6e						
Worffman	7e	6e						
Blackhall	7e	6e						
237:			---	---	---	---	---	---
Seaverson	7e	6e						
Blazon	7e	6e						
244:			---	---	---	3.00	---	4.5
Rock River	4e	3e						
251:			---	3.00	---	---	---	7.0
Grievess	6e	4e						
Blackhall	7e	6e						
252:			---	---	---	---	---	---
Blazon	7e	6e						
Blazon, thin solum	7e	7e						
Rentsac	7s	7e						
253:			---	---	---	---	---	---
Blazon	7e	6e						
Cushool	6e	4e						
254:			---	---	---	---	---	---
Abston	6s	4s						
Seaverson	7s	6s						
255:			---	---	---	---	---	---
Ponded soils	8	8						
256:			---	3.50	---	3.50	---	6.0
McFadden	6e	4e						
Brownsto	6s	6e						
Rawlins	6e	4e						

# Irrigated and Nonirrigated Yields by Map Unit

Carbon County Area, Wyoming

Map symbol and soil name	Land capability		Alfalfa hay		Grass hay		Pasture	
	N	I	N	I	N	I	N	I
			Tons	Tons	Tons	Tons	AUM	AUM
257:			—	—	—	—	—	—
Havre variant	4e	3s						
Glendive variant	4e	3s						
258:			—	—	—	3.00	—	4.5
Rock River	4e	3e						
Cushool	4e	4e						
260:			—	—	—	2.00	—	3.0
Ryan Park	6e	6e						
Rock River	4e	4e						
261:			—	5.00	—	3.00	—	—
Luhon	6e	4e						
Rock River	4e	3e						
262:			—	—	—	—	—	—
Rentsac	7s	7s						
Thermopolis	7e	6e						
263:			—	3.50	—	3.50	—	5.0
Edlin	4e	4e						
Carmody	6e	4e						
264:			—	—	—	—	—	—
Rentsac	7s	7e						
Rock outcrop	8	—						
272:			—	—	—	—	—	—
Rawlins	6e	4e						
275:			—	3.00	—	3.00	—	4.0
Poposhla	4e	3e						
Chaperton	6e	4e						
278:			—	—	—	3.00	—	4.0
Ryan Park	4e	3e						
Elk Mountain	6e	4e						
279:			—	—	—	—	—	—
Blackhall	7e	7e						
Grieves	4e	4e						



# Irrigated and Nonirrigated Yields by Map Unit

Carbon County Area, Wyoming

Map symbol and soil name	Land capability		Alfalfa hay		Grass hay		Pasture	
	N	I	N	I	N	I	N	I
			Tons	Tons	Tons	Tons	AUM	AUM
280:			---	---	---	---	---	---
Hazton variant	7e	7e						
Baggott variant	7e	7e						
282:			---	---	---	---	---	---
Tisworth	6s	6s						
284:			---	---	---	---	---	---
Blackhall	7e	7e						
Carmody	6e	4e						
Rock outcrop	8	8						
286:			---	---	---	---	---	---
Tisworth	6s	6s						
296:			---	---	---	---	---	---
Pinelli	6e	4e						
Boettcher	6e	4e						
332:			---	---	---	---	---	---
Chaperton, dry	6e	4e						
Hatermus	7e	6e						
Haterton	7e	6e						
333:			---	4.00	---	3.50	---	7.0
Sagecreek, alkali	6s	6s						
Sagecreek	4e	4e						
334:			---	3.50	---	3.00	---	6.0
Sagecreek, alkali	6s	6s						
336:			---	---	---	---	---	---
Haterton, thin solum	7e	7e						
Hatermus	7e	7e						
Haterton	7e	7e						
380:			---	---	---	---	---	---
Hazton variant	7e	6e						
Burgess	6e	4e						
400:			2.00	4.00	1.00	3.00	---	---
Firth variant	4w	3w						
Canburn variant	4w	3w						

# Irrigated and Nonirrigated Yields by Map Unit

Carbon County Area, Wyoming

Map symbol and soil name	Land capability		Alfalfa hay		Grass hay		Pasture	
	N	I	N	I	N	I	N	I
			Tons	Tons	Tons	Tons	AUM	AUM
483: Sandbranch	6s	6s	—	—	—	—	—	—
495: Chaperton, dry Sagecreek	6e 4e	4e 4e	—	—	—	—	—	—
502: Hagga, saline, alkali	4w	4w	—	—	—	3.00	—	—
703: Havre	4e	4e	—	—	—	—	—	—
761: Glendive variant	4e	4e	—	—	—	—	—	—
911: Forelle Diamondville	4e 4e	4e 4e	—	2.50	—	2.50	—	5.0
912: Evanston	4e	3e	—	3.00	—	3.00	—	6.0
928: Grieves variant Gerrard	4w 6w	4w 4w	—	—	—	—	—	—
931: Forelle	4e	3e	—	3.00	—	3.00	—	6.0
1202: Delplain variant Moring	7e 7e	7e 6e	—	—	—	—	—	—
1209: Zillman Peyton variant	6s 6e	6e 6e	—	—	—	—	—	—
1217: Zillman variant Highpoint	6s 7e	6e 6e	—	—	—	—	—	—

# Irrigated and Nonirrigated Yields by Map Unit

Carbon County Area, Wyoming

Map symbol and soil name	Land capability		Alfalfa hay		Grass hay		Pasture	
	N	I	N	I	N	I	N	I
			Tons	Tons	Tons	Tons	AUM	AUM
1251:			---	---	---	---	---	---
McFadden	6e	4e						
Blackhall	7e	7e						
Edlin	4e	4e						
1252:			---	---	---	---	---	---
Rentsac	7e	7e						
Blazon	7e	7e						
Rubble land	8	8						
1255:			---	---	---	---	---	---
Blackhall	7e	7e						
Rentsac	7e	7e						
1256:			---	---	---	---	---	---
Rawlins	4e	4e						
Rock River	4e	4e						
1260:			---	3.00	---	3.00	---	5.0
McFadden	6e	4e						
Edlin	6e	4e						
1912:			---	---	---	---	---	---
Peyton variant	4e	4e						
Evanston variant	4e	4e						
2080:			---	---	---	---	---	---
Pinelli variant	4e	3e						
Forelle	6e	3e						
2199:			---	---	---	---	---	---
Anchutz	4e	3e						
9120:			---	---	---	---	---	---
Evanston variant	4e	3e						
Evanston	4e	3e						
W:			---	---	---	---	---	---
Water	---	---						

**Appendix L**  
**NRCS Acreage and Proportionate Extent of the Soils**  
**for Carbon County, Wyoming**

DEQ 000410

# Acreage and Proportionate Extent of the Soils

Carbon County Area, Wyoming

Map symbol	Map unit name	Acres	Percent
4	Canburn loam, 0 to 2 percent slopes	397	*
8	Gerrard loam, 0 to 2 percent slopes	992	*
9	Grieves variant fine sandy loam, 0 to 3 percent slopes	3,759	*
9H	Grieves variant fine sandy loam, alkali, 0 to 3 percent slopes	1,283	*
13	Rhoamett silty clay, 0 to 2 percent slopes	388	*
15A	Poposhia loam, 0 to 2 percent slopes	20	*
15B	Poposhia loam, 2 to 6 percent slopes	320	*
18A	Alcova sandy loam, 0 to 2 percent slopes	1,000	*
18B	Alcova sandy loam, 2 to 6 percent slopes	1,000	*
18C	Alcova sandy loam, 6 to 12 percent slopes	1,000	*
18H	Alcova sandy loam, saline, 0 to 3 percent slopes	1,000	*
20	Debone silty clay loam, 0 to 3 percent slopes	1,300	*
22	Edlin sandy loam, 0 to 10 percent slopes	1,356	*
29	Canburn variant fine sandy loam, 0 to 2 percent slopes	1,046	*
31A	Tisworth sandy loam, 0 to 2 percent slopes	836	*
31B	Tisworth sandy loam, 2 to 6 percent slopes	332	*
34	Tresano sandy loam, 0 to 20 percent slopes	3,320	*
38A	Rock River sandy loam, 0 to 2 percent slopes	5,115	0.1
38B	Rock River sandy loam, 2 to 6 percent slopes	4,206	*
38C	Rock River sandy loam, 6 to 12 percent slopes	418	*
38H	Rock River sandy loam, saline, 0 to 3 percent slopes	861	*
40	Fiveoh very fine sandy loam, 2 to 10 percent slopes	3,232	*
40H	Fiveoh loam, saline, 0 to 3 percent slopes	412	*
43B	Grieves fine sandy loam, 2 to 6 percent slopes	833	*
45	Yetull variant loamy sand, 2 to 20 percent slopes	966	*
49	Firth variant fine sandy loam, 0 to 2 percent slopes	2,986	*
51W	Patent variant very fine sandy loam, 0 to 3 percent slopes	3,137	*
52	Laney loam, 0 to 6 percent slopes	1,260	*
52S	Laney variant-Slickspots complex, 3 to 10 percent slopes	700	*
53A	Pinelli loam, 0 to 2 percent slopes	262	*
59	Absher variant silty clay loam, 0 to 2 percent slopes	2,518	*
69	Kiltabar loam, 0 to 3 percent slopes	320	*
78A	Ryan Park sandy loam, 0 to 2 percent slopes	928	*
78B	Ryan Park sandy loam, 2 to 6 percent slopes	1,922	*
79D	Blackhall sandy loam, 6 to 30 percent slopes	160	*
86	Ansel loam, 10 to 30 percent slopes	260	*
101	Echemoor-Clayburn association, 0 to 10 percent slopes	260	*
102	Echemoor-Inchau association, 3 to 10 percent slopes	405	*
105	Starman-Barrett complex, 6 to 40 percent slopes	1,940	*
107	Starman-Vabem complex, 10 to 40 percent slopes	20	*
108	Lymanson-Youga association, 3 to 20 percent slopes	430	*
109	Lymanson-Roxal association, 3 to 20 percent slopes	300	*
11	Vabem-Inchau association, 6 to 30 percent slopes	1,580	*

## Acreage and Proportionate Extent of the Soils

Carbon County Area, Wyoming

Map symbol	Map unit name	Acres	Percent
118A	Alcova-Rock River sandy loams, 0 to 2 percent slopes	5,857	0.1
118B	Alcova-Rock River sandy loams, 2 to 6 percent slopes	191	*
128	McFadden-Brownsto-Blackhall complex, 6 to 20 percent slopes	1,760	*
135B	Cushool sandy loam, 0 to 6 percent slopes	2,028	*
138A	Rawlins-Bosler complex, 0 to 2 percent slopes	1,548	*
138B	Rawlins-Bosler complex, 2 to 6 percent slopes	2,140	*
140	Tisworth-Poposhia complex, 0 to 8 percent slopes	3,581	*
141	McFadden-Brownsto complex, 0 to 8 percent slopes	5,400	0.1
144	McFadden-Blackhall sandy loams, 2 to 15 percent slopes	4,013	*
147	Rogert-Quander-Rock outcrop complex, 20 to 50 percent slopes	1,000	*
200	Patent variant-Hagga complex, 0 to 3 percent slopes	4,899	0.1
208	Pinell-Forelle association, 3 to 15 percent slopes	2,235	*
209	Chaperton-Boettcher association, 3 to 10 percent slopes	3,480	*
210	Absher variant very fine sandy loam, 0 to 6 percent slopes	13,321	0.3
217	Dahlquist-Cragosen association, 6 to 40 percent slopes, eroded	9,080	0.2
218A	Alcova-Rawlins complex, 0 to 2 percent slopes	1,660	*
218B	Alcova-Rawlins complex, 2 to 6 percent slopes	1,000	*
221	Blazon-Chaperton association, 6 to 12 percent slopes	2,223	*
224A	McFadden-Brownsto complex, 0 to 2 percent slopes	2,040	*
224B	McFadden-Brownsto complex, 2 to 6 percent slopes	2,345	*
224w	McFadden-Brownsto complex, wet, 0 to 3 percent slopes	760	*
225	Cushool-Rock River association, 3 to 10 percent slopes	3,000	*
229	Cushool-Cushool variant association, 3 to 9 percent slopes	1,440	*
235	Blazon-Blazon thin solum loams, 6 to 40 percent slopes	2,304	*
236	Cushool-Worffman-Blackhall sandy loams, 6 to 30 percent slopes	9,556	0.2
237	Seaverson-Blazon complex, 3 to 30 percent slopes, eroded	7,308	0.2
244	Rock River sandy loam, 0 to 6 percent slopes	1,517	*
251	Grieves-Blackhall association, 3 to 30 percent slopes	10,647	0.2
252	Blazon, thin solum-Blazon-Rentsac complex, 10 to 50 percent slopes, eroded	32,645	0.7
253	Blazon-Cushool association, 2 to 20 percent slopes	12,280	0.3
254	Abston-Seaverson complex, 0 to 6 percent slopes	18,974	0.4
255	Playa lakes	660	*
256	McFadden-Brownsto-Rawlins complex 6 to 20 percent slopes	9,836	0.2
257	Havre variant-Glendive variant complex, 0 to 3 percent slopes	5,226	0.1
258	Rock River-Cushool sandy loams, 0 to 12 percent slopes	11,927	0.3
260	Ryan Park-Rock River association, 2 to 20 percent slopes	12,181	0.3
261	Luhon-Rock River association, 0 to 10 percent slopes	7,013	0.2
262	Thermopolis-Rentsac complex, 10 to 30 percent slopes	5,199	0.1
263	Edlin-Carmody sandy loams, 3 to 15 percent slopes	2,448	*
264	Rentsac-rock outcrop complex, 5 to 50 percent slopes	980	*
272	Rawlins gravelly loamy sand, 0 to 10 percent slopes	18,434	0.4
275	Poposhia-Chaperton loams, 0 to 5 percent slopes	4,161	*
278	Ryan Park-Elk Mountain loamy fine sands, 2 to 7 percent slopes	6,000	0.1

# Acreage and Proportionate Extent of the Soils

Carbon County Area, Wyoming

Map symbol	Map unit name	Acres	Percent
279	Blackhall-Grieves fine sandy loams, 10 to 40 percent slopes	2,240	*
280	Hazton variant-Baggott variant gravelly sandy loams, 5 to 50 percent slopes	2,500	*
282	Tisworth loam, 0 to 5 percent slopes	4,795	0.1
284	Blackhall-Carmody-Rock outcrop complex, 3 to 50 percent slopes	1,968	*
286	Tisworth fine sandy loam, 1 to 5 percent slopes	4,398	*
296	Pinelli-Boettcher clay loams, 2 to 20 percent slopes	650	*
332	Chaperton,dry-Haterton-Hatermus loams, 2 to 15 percent slopes	9,900	0.2
333	Sagecreek alkali-Sagecreek loams, 0 to 10 percent slopes	12,720	0.3
334	Sagecreek loam, alkali, 1 to 8 percent slopes	3,680	*
336	Haterton,thin solum-Hatermus-Haterton loams, 8 to 30 percent slopes	3,185	*
380	Hazton variant-Burgess association, 5 to 30 percent slopes	1,000	*
400	Firth variant-Canburn variant complex, 0 to 3 percent slopes	2,675	*
483	Sandbranch fine sandy loam, 0 to 6 percent slopes	3,175	*
495	Chaperton,dry-Sagecreek loams, 2 to 10 percent slopes	650	*
502	Hagga loam, saline, alkali, 0 to 2 percent slopes	643	*
703	Havre loam, 0 to 3 percent slopes	2,170	*
761	Glendive variant fine sandy loam, 0 to 3 percent slopes	603	*
911	Forelle-Diamondville loams, 3 to 15 percent slopes	80	*
912	Evanston loam, 0 to 6 percent slopes	2,496	*
928	Grieves variant-Gerrard complex, 0 to 3 percent slopes	4,589	0.1
931	Forelle loam, 0 to 6 percent slopes	4,800	0.1
1202	Delpain variant-Morling complex, 6 to 30 percent slopes	2,974	*
1209	Zillman-Peyton variant association, 10 to 50 percent slopes	7,000	0.2
1217	Zillman variant-Highpoint association, 10 to 60 percent slopes	5,042	0.1
1251	McFadden-Blackhall-Edlin sandy loams, 5 to 50 percent slopes	20,463	0.5
1252	Rentsac-Blazon-Rubble land association, 10 to 50 percent slopes	20,816	0.5
1255	Blackhall-Rentsac complex, 10 to 40 percent slopes	6,335	0.1
1256	Rawlins-Rock River association, 0 to 15 percent slopes	13,968	0.3
1260	McFadden-Edlin association, 2 to 20 percent slopes	17,571	0.4
1912	Peyton variant-Evanston variant fine sandy loams, 0 to 6 percent slopes	9,350	0.2
2080	Pinelli variant-Forelle association, 0 to 10 percent slopes	2,858	*
2199	Anchutz sandy loam, 0 to 6 percent slopes	15,980	0.4
9120	Evanston variant-Evanston complex, 0 to 6 percent slopes	5,011	0.1
W	Water	36,203	0.8
Total		541,365	12.2

\* Less than 0.1 percent.

**Appendix M**  
**NRCS Rangeland Productivity and Plant Composition**



# Rangeland Productivity and Plant Composition

Carbon County Area, Wyoming

Map symbol and soil name	Ecological site	Total dry-weight production			Characteristic vegetation	Rangeland composition
		Favorable year	Normal year	Unfavorable year		
		Lb/Ac	Lb/Ac	Lb/Ac	Pct	
4: Canburn	SUBIRRIGATED (10-14SE)	4,300	3,700	3,000	Basin wildrye	20
					Bluejoint	15
					Northern reedgrass	15
					Prairie cordgrass	15
					Nebraska sedge	10
					Canada wildrye	5
					Other perennial forbs	5
					Slender wheatgrass	5
					Tufted hairgrass	5
					Western wheatgrass	1
8: Gerrard	WETLAND (10-14SE)	6,000	5,000	3,500	Nebraska sedge	30
					Northern reedgrass	10
					Willow	10
					American bistort	5
					American mannagrass	5
					Arrowgrass	5
					Baltic rush	5
					Blueeyed grass	5
					Clustered field sedge	5
					Common reed	5
					Horsetail	5
					Tufted hairgrass	5
					Water hemlock	5

# Rangeland Productivity and Plant Composition

Carbon County Area, Wyoming

Map symbol and soil name	Ecological site	Total dry-weight production			Characteristic vegetation	Rangeland composition
		Favorable year	Normal year	Unfavorable year		
		Lb/Ac	Lb/Ac	Lb/Ac	Pct	
9: Grieves variant	LOWLAND (10-14SE)	3,000	2,300	1,600	Western wheatgrass	20
					Basin wildrye	10
					Narrowleaf cottonwood	10
					Needleandthread	10
					Silver sagebrush	10
					Big sagebrush	5
					Canby bluegrass	5
					Indian ricegrass	5
					Prairie Junegrass	5
					Yellow rabbitbrush	5
9H: Grieves variant, alkali	SALINE LOWLAND (10-14SE)	2,500	1,800	1,200	Alkali sacaton	15
					Basin wildrye	15
					Greasewood	15
					Indian ricegrass	5
					Inland saltgrass	5
					Western wheatgrass	5

# Rangeland Productivity and Plant Composition

Carbon County Area, Wyoming

Map symbol and soil name	Ecological site	Total dry-weight production			Characteristic vegetation	Rangeland composition
		Favorable year	Normal year	Unfavorable year		
		Lb/Ac	Lb/Ac	Lb/Ac		Pct
13: Rhoamett	SALINE LOWLAND (10-14SE)	2,500	1,800	1,200	Streambank wheatgrass	40
					Green needlegrass	10
					Birdfoot sagebrush	5
					Bluebunch wheatgrass	5
					Muttongrass	5
					Other perennial forbs	5
					Other perennial grasses	5
					Plains reedgrass	5
					Prairie Junegrass	5
					Sandberg bluegrass	5
					Truckee rabbitbrush	5
					Winterfat	5
15A: Poposhia	LOAMY (10-14SE)	1,400	1,100	600	---	---
15B: Poposhia	LOAMY (10-14SE)	1,400	1,100	600	---	---
18A: Alcova	SANDY (10-14SE)	1,500	1,200	700	---	---
18B: Alcova	SANDY (10-14SE)	1,500	1,200	700	---	---
18C: Alcova	SANDY (10-14SE)	1,500	1,200	700	---	---

# Rangeland Productivity and Plant Composition

Carbon County Area, Wyoming

Map symbol and soil name	Ecological site	Total dry-weight production			Characteristic vegetation	Rangeland composition
		Favorable year	Normal year	Unfavorable year		
		Lb/Ac	Lb/Ac	Lb/Ac		Pct
18H: Alcova, saline	SALINE LOWLAND (10-14SE)	2,500	1,800	1,200	—	—
20: Debone	SALINE UPLAND (7-9GR)	650	500	300	Greasewood Basin wildrye Fourwing saltbush Indian ricegrass Western wheatgrass Alkali sacaton Bottlebrush squirreltail Bud sagebrush	20 10 10 10 10 5 5 5
22: Edlin	SANDY (10-14SE)	1,500	1,200	700	—	—
29: Canburn variant	SUBIRRIGATED (10-14SE)	4,000	3,000	2,500	Basin wildrye Tufted hairgrass Western wheatgrass Nebraska sedge Northern reedgrass Slender wheatgrass Willow Canada wildrye	40 20 10 5 5 5 5 3

# Rangeland Productivity and Plant Composition

Carbon County Area, Wyoming

Map symbol and soil name	Ecological site	Total dry-weight production			Characteristic vegetation	Rangeland composition
		Favorable year	Normal year	Unfavorable year		
		Lb/Ac	Lb/Ac	Lb/Ac		Pct
31A: Tisworth	SALINE UPLAND (10-14SE)	650	500	300	Fourwing saltbush	50
					Streambank wheatgrass	15
					Indian ricegrass	10
					Winterfat	10
					Bottlebrush squirreltail	5
					Greasewood	5
					Other perennial forbs	5
31B: Tisworth	SALINE UPLAND (10-14SE)	650	500	300	Fourwing saltbush	50
					Streambank wheatgrass	15
					Indian ricegrass	10
					Winterfat	10
					Bottlebrush squirreltail	5
					Greasewood	5
					Other perennial forbs	5
34: Tresano	LOAMY (7-9GR)	1,400	1,100	600	—	—

# Rangeland Productivity and Plant Composition

Carbon County Area, Wyoming

Map symbol and soil name	Ecological site	Total dry-weight production			Characteristic vegetation	Rangeland composition
		Favorable year	Normal year	Unfavorable year		
		Lb/Ac	Lb/Ac	Lb/Ac	Pct	
38A: Rock River	SANDY (10-14SE)	1,500	1,200	700	Needleandthread	25
					Streambank wheatgrass	15
					Big sagebrush	10
					Bluebunch wheatgrass	10
					Canby bluegrass	10
					Indian ricegrass	10
					Bottlebrush squirreltail	5
					Truckee rabbitbrush	5
38B: Rock River	SANDY (10-14SE)	1,500	1,200	700	Needleandthread	25
					Streambank wheatgrass	15
					Big sagebrush	10
					Bluebunch wheatgrass	10
					Canby bluegrass	10
					Indian ricegrass	10
					Bottlebrush squirreltail	5
					Truckee rabbitbrush	5
38C: Rock River	SANDY (10-14SE)	1,500	1,200	700	Needleandthread	25
					Streambank wheatgrass	15
					Big sagebrush	10
					Bluebunch wheatgrass	10
					Canby bluegrass	10
					Indian ricegrass	10
					Bottlebrush squirreltail	5
					Truckee rabbitbrush	5

# Rangeland Productivity and Plant Composition

Carbon County Area, Wyoming

Map symbol and soil name	Ecological site	Total dry-weight production			Characteristic vegetation	Rangeland composition
		Favorable year	Normal year	Unfavorable year		
		Lb/Ac	Lb/Ac	Lb/Ac		Pct
38H: Rock River, saline	SANDY (10-14SE)	1,500	1,200	700	—	—
40: Fiveoh	SANDY (10-14SE)	1,500	1,200	700	—	—
40H: Fiveoh, saline	SALINE LOWLAND (10-14SE)	2,500	1,800	1,200	—	—
43B: Grieves	SANDY (10-14SE)	1,500	1,200	700	—	—
45: Yetull variant	SANDS (10-14SE)	1,700	1,400	900	—	—
49: Firth variant	LOWLAND (10-14SE)	3,000	2,300	1,600	—	—
51W: Patent variant	SALINE LOWLAND (10-14SE)	2,500	1,800	1,200	—	—

# Rangeland Productivity and Plant Composition

Carbon County Area, Wyoming

Map symbol and soil name	Ecological site	Total dry-weight production			Characteristic vegetation	Rangeland composition
		Favorable year	Normal year	Unfavorable year		
		Lb/Ac	Lb/Ac	Lb/Ac		Pct
52: Laney	SALINE UPLAND (7-9GR)	600	450	300	Fourwing saltbush	50
					Other shrubs	15
					Bottlebrush squirreltail	10
					Indian ricegrass	10
					Other perennial grasses	10
					Bud sagebrush	5
					Sandberg bluegrass	5
					Streambank wheatgrass	5
					Winterfat	5
52S: Laney variant	SALINE LOWLAND, DRAINED (7-9GR)	2,000	1,200	800	—	—
Slickspots	—	—	—	—	—	—
53A: Pinelli	LOAMY (10-14SE)	1,400	1,100	600	Streambank wheatgrass	40
					Big sagebrush	10
					Needleandthread	10
					Bluebunch wheatgrass	5
					Green needlegrass	5
					Needleleaf sedge	5
					Plains reedgrass	5
					Prairie Junegrass	5
					Sandberg bluegrass	5
59: Absher variant	SALINE LOWLAND (10-14SE)	2,500	1,800	1,200	—	—



# Rangeland Productivity and Plant Composition

Carbon County Area, Wyoming

Map symbol and soil name	Ecological site	Total dry-weight production			Characteristic vegetation	Rangeland composition
		Favorable year	Normal year	Unfavorable year		
		Lb/Ac	Lb/Ac	Lb/Ac		Pct
69: Kiltabar	SALINE LOWLAND (10-14SE)	2,500	1,800	1,200	---	---
78A: Ryan Park	SANDY (10-14SE)	1,500	1,200	700	---	---
78B: Ryan Park	SANDY (10-14SE)	1,500	1,200	700	---	---
79D: Blackhall	SHALLOW SANDY (10-14SE)	1,200	900	700	Needleandthread Bluebunch wheatgrass Sedge Black sagebrush Indian ricegrass Muttongrass Western wheatgrass Big sagebrush Prairie Junegrass	25 20 15 10 10 10 10 5 5
86: Ansel	---	---	---	---	---	---

# Rangeland Productivity and Plant Composition

Carbon County Area, Wyoming

Map symbol and soil name	Ecological site	Total dry-weight production			Characteristic vegetation	Rangeland composition
		Favorable year	Normal year	Unfavorable year		
		Lb/Ac	Lb/Ac	Lb/Ac	Pct	
101: Echemoor	LOAMY (15-19SE)	2,000	1,500	800	Bluebunch wheatgrass	20
					Griffith wheatgrass	10
					Idaho fescue	10
					Needleandthread	10
					Basin wildrye	5
					Big sagebrush	5
					Parry's danthonia	5
					Prairie Junegrass	5
					Spike fescue	5
					Threetip sagebrush	5
Clayburn	LOAMY (15-19SE)	2,400	2,000	1,400	Idaho fescue	20
					Streambank wheatgrass	15
					Antelope bitterbrush	10
					Big sagebrush	10
					Canby bluegrass	10
					Other perennial grasses	10
					Spike fescue	10
					Mountain brome	5
					Other perennial forbs	5

# Rangeland Productivity and Plant Composition

Carbon County Area, Wyoming

Map symbol and soil name	Ecological site	Total dry-weight production			Characteristic vegetation	Rangeland composition
		Favorable year	Normal year	Unfavorable year		
		Lb/Ac	Lb/Ac	Lb/Ac		Pct
102: Echemoor	LOAMY (15-19SE)	2,000	1,500	800	Bluebunch wheatgrass Griffith wheatgrass Idaho fescue Needleandthread Basin wildrye Big sagebrush Parry's danthonia Prairie Junegrass Spike fescue Threetip sagebrush	20 10 10 10 5 5 5 5 5 5
Inchau	LOAMY (15-19SE)	2,000	1,500	800	—	—
105: Starman	VERY SHALLOW (15-19SE)	600	500	300	Bluebunch wheatgrass Mountain mahogany Antelope bitterbrush Idaho fescue Needleandthread Black sagebrush Juniper Prairie Junegrass Sandberg bluegrass	20 15 10 10 10 5 5 5 5

# Rangeland Productivity and Plant Composition

Carbon County Area, Wyoming

Map symbol and soil name	Ecological site	Total dry-weight production			Characteristic vegetation	Rangeland composition  Pct
		Favorable year  Lb/Ac	Normal year  Lb/Ac	Unfavorable year  Lb/Ac		
105: Barrett	SHALLOW LOAMY (15-19SE)	1,200	900	700	Needleandthread Bluebunch wheatgrass Black sagebrush Indian ricegrass Muttongrass Threadleaf sedge Sandberg bluegrass Winterfat	20 15 10 10 10 10 5 5
107: Starman	VERY SHALLOW (15-19SE)	600	500	300	Bluebunch wheatgrass Mountain mahogany Antelope bitterbrush Idaho fescue Needleandthread Black sagebrush Juniper Prairie Junegrass Sandberg bluegrass	20 15 10 10 10 5 5 5 5

# Rangeland Productivity and Plant Composition

Carbon County Area, Wyoming

Map symbol and soil name	Ecological site	Total dry-weight production			Characteristic vegetation	Rangeland composition
		Favorable year	Normal year	Unfavorable year		
		Lb/Ac	Lb/Ac	Lb/Ac		Pct
107: Vabem	SHALLOW LOAMY (15-19SE)	1,400	1,100	800	Bluebunch wheatgrass	20
					Griffith wheatgrass	10
					Threetip sagebrush	10
					Antelope bitterbrush	5
					Black sagebrush	5
					Curleaf mountain mahogany	5
					Idaho fescue	5
					Mountain muhly	5
					Prairie Junegrass	5
					Sandberg bluegrass	5
					Spike fescue	5
108: Lymanson	LOAMY (15-19SE)	1,200	900	700	Bluebunch wheatgrass	20
					Western wheatgrass	20
					Black sagebrush	10
					Muttongrass	10
					Needleandthread	10
					Prairie sagewort	5
Youga	LOAMY (15-19SE)	1,200	900	700	---	---

# Rangeland Productivity and Plant Composition

Carbon County Area, Wyoming

Map symbol and soil name	Ecological site	Total dry-weight production			Characteristic vegetation	Rangeland composition
		Favorable year	Normal year	Unfavorable year		
		Lb/Ac	Lb/Ac	Lb/Ac	Pct	
109:						
Lymanson	LOAMY (15-19SE)	1,200	900	700	Bluebunch wheatgrass	20
					Western wheatgrass	20
					Black sagebrush	10
					Muttongrass	10
					Needleandthread	10
					Prairie sagewort	5
Roxal	SHALLOW LOAMY (15-19SE)	1,400	1,100	800	—	—
111:						
Vabem	SHALLOW LOAMY (15-19SE)	1,400	1,100	800	—	—
Inchau	LOAMY (15-19SE)	1,200	900	700	—	—
118A:						
Alcova	LOAMY (10-14SE)	1,400	1,100	600	—	—
Rock River	LOAMY (10-14SE)	1,400	1,100	600	—	—
118B:						
Alcova	LOAMY (10-14SE)	1,400	1,100	600	—	—
Rock River	LOAMY (10-14SE)	1,400	1,100	600	—	—
128:						
McFadden	SHALLOW SANDY (10-14SE)	1,200	900	700	—	—
Brownsto	GRAVELLY (10-14SE)	650	450	300	—	—

# Rangeland Productivity and Plant Composition

Carbon County Area, Wyoming

Map symbol and soil name	Ecological site	Total dry-weight production			Characteristic vegetation	Rangeland composition
		Favorable year	Normal year	Unfavorable year		
		Lb/Ac	Lb/Ac	Lb/Ac	Pct	
128: Blackhall	SHALLOW SANDY (10-14SE)	1,200	900	700	—	—
135B: Cushool	SANDY (10-14SE)	1,500	1,200	700	Needleandthread	25
					Indian ricegrass	20
					Streambank wheatgrass	20
					Silver sagebrush	10
					Big sagebrush	5
					Bluebunch wheatgrass	5
					Plains reedgrass	5
					Sandberg bluegrass	5
138A: Rawlins	SHALLOW SANDY (10-14SE)	1,200	900	700	—	—
Bosler	SANDY (10-14SE)	1,500	1,200	700	Needleandthread	30
					Streambank wheatgrass	20
					Indian ricegrass	15
					Silver sagebrush	10
					Threadleaf sedge	10
					Bluebunch wheatgrass	5
					Plains reedgrass	5
					Prairie Junegrass	5
					Sandberg bluegrass	5
138B: Rawlins	SHALLOW SANDY (10-14SE)	1,200	900	700	—	—

# Rangeland Productivity and Plant Composition

Carbon County Area, Wyoming

Map symbol and soil name	Ecological site	Total dry-weight production			Characteristic vegetation	Rangeland composition
		Favorable year	Normal year	Unfavorable year		
		Lb/Ac	Lb/Ac	Lb/Ac		Pct
138B: Bosler	SANDY (10-14SE)	1,500	1,200	700	Needleandthread Streambank wheatgrass Indian ricegrass Silver sagebrush Threadleaf sedge Bluebunch wheatgrass Plains reedgrass Prairie Junegrass Sandberg bluegrass	30 20 15 10 10 5 5 5 5
140: Tisworth	SALINE UPLAND (10-14SE)	650	500	300	Fourwing saltbush Streambank wheatgrass Indian ricegrass Winterfat Bottlebrush squirreltail Greasewood Other perennial forbs	50 15 10 10 5 5 5
Poposhia	LOAMY (10-14SE)	1,400	1,100	600	—	—
141: McFadden	SHALLOW SANDY (10-14SE)	1,200	900	700	—	—
Brownsto	GRAVELLY (10-14SE)	650	450	300	—	—
144: McFadden	SHALLOW SANDY (10-14SE)	1,200	900	700	—	—



# Rangeland Productivity and Plant Composition

Carbon County Area, Wyoming

Map symbol and soil name	Ecological site	Total dry-weight production			Characteristic vegetation	Rangeland composition
		Favorable year	Normal year	Unfavorable year		
		Lb/Ac	Lb/Ac	Lb/Ac	Pct	
144: Blackhall	SHALLOW SANDY (10-14SE)	1,200	900	700	Needleandthread	25
					Bluebunch wheatgrass	20
					Sedge	15
					Black sagebrush	10
					Indian ricegrass	10
					Muttongrass	10
					Western wheatgrass	10
					Big sagebrush	5
					Prairie Junegrass	5
147: Rogert	VERY SHALLOW (15-19SE)	1,400	1,000	700	Western wheatgrass	20
					Antelope bitterbrush	5
					Bluebunch wheatgrass	5
					Needleandthread	5
					Prairie Junegrass	5
Quander	SHALLOW LOAMY (15-19SE)	1,500	1,200	1,000	Bluebunch wheatgrass	25
					Antelope bitterbrush	15
					Big sagebrush	15
					Idaho fescue	15
					Muttongrass	10
					Common snowberry	5
					Saskatoon serviceberry	5
Rock outcrop	---	---	---	---	---	---

# Rangeland Productivity and Plant Composition

Carbon County Area, Wyoming

Map symbol and soil name	Ecological site	Total dry-weight production			Characteristic vegetation	Rangeland composition
		Favorable year	Normal year	Unfavorable year		
		Lb/Ac	Lb/Ac	Lb/Ac		Pct
200:						
Patent variant	SALINE LOWLAND (10-14SE)	2,500	1,800	1,200	—	—
Hagga	SALINE SUBIRRIGATED (10-14SE)	2,500	2,000	1,500	Western wheatgrass Sedge Basin wildrye Rush Slender wheatgrass	40 25 5 5 5
208:						
Pinelli	LOAMY (10-14SE)	1,400	1,100	600	—	—
Forelle	LOAMY (10-14SE)	1,400	1,100	600	—	—
209:						
Chaperton	LOAMY (10-14SE)	1,400	1,100	600	Western wheatgrass Needleandthread Big sagebrush Prairie Junegrass Sandberg bluegrass	35 15 10 5 5
Boettcher	LOAMY (10-14SE)	1,400	1,100	600	—	—

# Rangeland Productivity and Plant Composition

Carbon County Area, Wyoming

Map symbol and soil name	Ecological site	Total dry-weight production			Characteristic vegetation	Rangeland composition
		Favorable year	Normal year	Unfavorable year		
		Lb/Ac	Lb/Ac	Lb/Ac	Pct	
210: Absher variant	SALINE UPLAND (10-14SE)	650	500	300	Gardner's saltbush	40
					Indian ricegrass	10
					Western wheatgrass	10
					Birdfoot sagebrush	5
					Bottlebrush squirreltail	5
					Sandberg bluegrass	5
					Desert biscuitroot	1
					Spiny phlox	1
217: Dahlquist	GRAVELLY (10-14SE)	650	450	300	—	—
Cragosen	GRAVELLY (10-14SE)	650	450	300	—	—
218A: Alcova	SANDY (10-14SE)	1,500	1,200	700	Needleandthread	25
					Streambank wheatgrass	20
					Indian ricegrass	10
					Threadleaf sedge	10
					Big sagebrush	5
					Bluebunch wheatgrass	5
					Prairie Junegrass	5
Rawlins	SHALLOW SANDY (10-14SE)	1,200	900	700	—	—

# Rangeland Productivity and Plant Composition

Carbon County Area, Wyoming

Map symbol and soil name	Ecological site	Total dry-weight production			Characteristic vegetation	Rangeland composition
		Favorable year	Normal year	Unfavorable year		
		Lb/Ac	Lb/Ac	Lb/Ac		Pct
218B: Alcova	SANDY (10-14SE)	1,500	1,200	700	Needleandthread Streambank wheatgrass Indian ricegrass Threadleaf sedge Big sagebrush Bluebunch wheatgrass Prairie Junegrass	25 20 10 10 5 5 5
Rawlins	SHALLOW SANDY (10-14SE)	1,200	900	700	---	---
221: Blazon	SHALLOW LOAMY (10-14 SE)	1,200	900	700	Bluebunch wheatgrass Western wheatgrass Muttongrass Black sagebrush Indian ricegrass Sandberg bluegrass Yellow rabbitbrush	20 20 10 5 5 5 5
Chaperton	LOAMY (10-14SE)	1,400	1,100	600	Western wheatgrass Needleandthread Big sagebrush Prairie Junegrass Sandberg bluegrass	35 15 10 5 5
224A: McFadden	SHALLOW SANDY (10-14SE)	1,200	900	700	---	---

# Rangeland Productivity and Plant Composition

Carbon County Area, Wyoming

Map symbol and soil name	Ecological site	Total dry-weight production			Characteristic vegetation	Rangeland composition
		Favorable year	Normal year	Unfavorable year		
		Lb/Ac	Lb/Ac	Lb/Ac	Pct	
224A: Brownsto	GRAVELLY (10-14SE)	650	450	300	---	---
224B: McFadden	SHALLOW SANDY (10-14SE)	1,200	900	700	---	---
Brownsto	GRAVELLY (10-14SE)	650	450	300	---	---
224w: McFadden, wet	SHALLOW SANDY (10-14SE)	1,200	900	700	---	---
Brownsto, wet	GRAVELLY (10-14SE)	650	450	300	---	---
225: Cushool	SANDY (10-14SE)	1,500	1,200	700	Needleandthread	25
					Indian ricegrass	20
					Streambank wheatgrass	20
					Silver sagebrush	10
					Big sagebrush	5
					Bluebunch wheatgrass	5
					Plains reedgrass	5
					Sandberg bluegrass	5

# Rangeland Productivity and Plant Composition

Carbon County Area, Wyoming

Map symbol and soil name	Ecological site	Total dry-weight production			Characteristic vegetation	Rangeland composition
		Favorable year	Normal year	Unfavorable year		
		Lb/Ac	Lb/Ac	Lb/Ac	Pct	
225: Rock River	SANDY (10-14SE)	1,500	1,200	700	Needleandthread	25
					Streambank wheatgrass	15
					Big sagebrush	10
					Bluebunch wheatgrass	10
					Canby bluegrass	10
					Indian ricegrass	10
					Bottlebrush squirreltail	5
					Truckee rabbitbrush	5
229: Cushool	SANDY (10-14SE)	1,500	1,200	700	Needleandthread	25
					Indian ricegrass	20
					Streambank wheatgrass	20
					Silver sagebrush	10
					Big sagebrush	5
					Bluebunch wheatgrass	5
					Plains reedgrass	5
					Sandberg bluegrass	5
Cushool variant	SANDY (10-14SE)	1,500	1,200	700	—	—

# Rangeland Productivity and Plant Composition

Carbon County Area, Wyoming

Map symbol and soil name	Ecological site	Total dry-weight production			Characteristic vegetation	Rangeland composition
		Favorable year	Normal year	Unfavorable year		
		Lb/Ac	Lb/Ac	Lb/Ac		Pct
235:						
Blazon	SHALLOW LOAMY (10-14 SE)	1,200	900	700	Bluebunch wheatgrass	20
					Western wheatgrass	20
					Muttongrass	10
					Black sagebrush	5
					Indian ricegrass	5
					Sandberg bluegrass	5
					Yellow rabbitbrush	5
Blazon, THIN SOLUM	SHALE (10-14SE)	1,200	900	700	Bluebunch wheatgrass	20
					Western wheatgrass	20
					Muttongrass	10
					Black sagebrush	5
					Indian ricegrass	5
					Sandberg bluegrass	5
					Yellow rabbitbrush	5
236:						
Cushool	SANDY (10-14SE)	1,500	1,200	700	---	---
Worfman	SHALLOW SANDY (10-14SE)	1,200	900	700	Bluebunch wheatgrass	20
					Indian ricegrass	10
					Needleandthread	10
					Prairie Junegrass	5
					Sandberg bluegrass	5
					Skunkbush sumac	5
					Truckee rabbitbrush	5
					Western wheatgrass	5
					Winterfat	5

# Rangeland Productivity and Plant Composition

Carbon County Area, Wyoming

Map symbol and soil name	Ecological site	Total dry-weight production			Characteristic vegetation	Rangeland composition  Pct
		Favorable year  Lb/Ac	Normal year  Lb/Ac	Unfavorable year  Lb/Ac		
236: Blackhall	SHALLOW SANDY (10-14SE)	1,200	900	700	Needleandthread Bluebunch wheatgrass Sedge Black sagebrush Indian ricegrass Muttongrass Western wheatgrass Big sagebrush Prairie Junegrass	25 20 15 10 10 10 10 5 5
237: Seaverson	SALINE UPLAND (10-14SE)	650	500	300	Gardner's saltbush Indian ricegrass Western wheatgrass Bottlebrush squirreltail Birdfoot sagebrush Desert biscuitroot Sandberg bluegrass	40 15 15 10 5 5 5
Blazon	SHALLOW LOAMY (10-14 SE)	1,200	900	700	Bluebunch wheatgrass Western wheatgrass Muttongrass Black sagebrush Indian ricegrass Sandberg bluegrass Yellow rabbitbrush	20 20 10 5 5 5 5



# Rangeland Productivity and Plant Composition

Carbon County Area, Wyoming

Map symbol and soil name	Ecological site	Total dry-weight production			Characteristic vegetation	Rangeland composition
		Favorable year	Normal year	Unfavorable year		
		Lb/Ac	Lb/Ac	Lb/Ac		Pct
244: Rock River	SANDY (10-14SE)	1,500	1,200	700	Needleandthread	25
					Streambank wheatgrass	15
					Big sagebrush	10
					Bluebunch wheatgrass	10
					Canby bluegrass	10
					Indian ricegrass	10
					Bottlebrush squirreltail	5
					Truckee rabbitbrush	5
251: Grieves	SANDY (10-14SE)	1,500	1,200	700	Needleandthread	25
					Streambank wheatgrass	15
					Big sagebrush	10
					Bluebunch wheatgrass	10
					Canby bluegrass	10
					Indian ricegrass	10
					Bottlebrush squirreltail	5
					Other perennial forbs	5
					Other perennial grasses	5
					Truckee rabbitbrush	5

# Rangeland Productivity and Plant Composition

Carbon County Area, Wyoming

Map symbol and soil name	Ecological site	Total dry-weight production			Characteristic vegetation	Rangeland composition
		Favorable year	Normal year	Unfavorable year		
		Lb/Ac	Lb/Ac	Lb/Ac		Pct
251:						
Blackhall	SHALLOW SANDY (10-14SE)	1,200	900	700	Needleandthread	25
					Bluebunch wheatgrass	20
					Sedge	15
					Black sagebrush	10
					Indian ricegrass	10
					Muttongrass	10
					Western wheatgrass	10
					Big sagebrush	5
					Prairie Junegrass	5
252:						
Blazon	SHALLOW LOAMY (10-14 SE)	1,400	1,100	800	—	—
Blazon, thin solum	SHALE (10-14SE)	400	300	200	—	—
Rentsac	VERY SHALLOW (10-14SE)	600	450	250	—	—
253:						
Blazon	SHALLOW LOAMY (10-14 SE)	1,400	1,100	800	Bluebunch wheatgrass	20
					Western wheatgrass	20
					Muttongrass	10
					Black sagebrush	5
					Indian ricegrass	5
					Sandberg bluegrass	5
					Yellow rabbitbrush	5

# Rangeland Productivity and Plant Composition

Carbon County Area, Wyoming

Map symbol and soil name	Ecological site	Total dry-weight production			Characteristic vegetation	Rangeland composition
		Favorable year	Normal year	Unfavorable year		
		Lb/Ac	Lb/Ac	Lb/Ac	Pct	
253: Cushool	LOAMY (10-14SE)	1,400	1,100	600	Streambank wheatgrass	40
					Big sagebrush	10
					Needleandthread	10
					Bluebunch wheatgrass	5
					Green needlegrass	5
					Needleleaf sedge	5
					Other perennial forbs	5
					Other perennial grasses	5
					Plains reedgrass	5
					Prairie Junegrass	5
					Sandberg bluegrass	5
254: Abston	IMPERVIOUS CLAY (10-14SE)	600	400	250	---	---
Seaverson	IMPERVIOUS CLAY (10-14SE)	600	400	250	Birdfoot sagebrush	25
					Western wheatgrass	25
					Bottlebrush squirreltail	5
					Desert biscuitroot	5
					Gardner's saltbush	5
					Indian ricegrass	5
					Sandberg bluegrass	5
255: Ponded soils	---	---	---	---	---	---
256: McFadden	SHALLOW SANDY (10-14SE)	1,200	900	700	---	---

# Rangeland Productivity and Plant Composition

Carbon County Area, Wyoming

Map symbol and soil name	Ecological site	Total dry-weight production			Characteristic vegetation	Rangeland composition
		Favorable year	Normal year	Unfavorable year		
		Lb/Ac	Lb/Ac	Lb/Ac		Pct
256:						
Brownsto	GRAVELLY (10-14SE)	650	450	300	Bluebunch wheatgrass	25
					Needleandthread	10
					Big sagebrush	5
					Black sagebrush	5
					Blue grama	5
					Bottlebrush squirreltail	5
					Indian ricegrass	5
					Sandberg bluegrass	5
Rawlins	SHALLOW SANDY (10-14SE)	1,200	900	700	—	—
257:						
Havre variant	SALINE LOWLAND (10-14SE)	2,500	1,800	1,200	—	—
Glendive variant	SALINE LOWLAND (10-14SE)	2,500	1,800	1,200	—	—
258:						
Rock River	LOAMY (10-14SE)	1,400	1,100	600	Western wheatgrass	35
					Needleandthread	15
					Big sagebrush	10
					Bluebunch wheatgrass	10
					Blue grama	5
					Canby bluegrass	5
					Indian ricegrass	5
					Truckee rabbitbrush	5

# Rangeland Productivity and Plant Composition

Carbon County Area, Wyoming

Map symbol and soil name	Ecological site	Total dry-weight production			Characteristic vegetation	Rangeland composition
		Favorable year	Normal year	Unfavorable year		
		Lb/Ac	Lb/Ac	Lb/Ac		Pct
258: Cushool	LOAMY (10-14SE)	1,400	1,100	600	Streambank wheatgrass	40
					Big sagebrush	10
					Needleandthread	10
					Bluebunch wheatgrass	5
					Green needlegrass	5
					Needleleaf sedge	5
					Other perennial forbs	5
					Other perennial grasses	5
					Plains reedgrass	5
					Prairie Junegrass	5
					Sandberg bluegrass	5
260: Ryan Park	SANDY (10-14SE)	1,500	1,200	700	Needleandthread	30
					Streambank wheatgrass	15
					Indian ricegrass	10
					Plains reedgrass	5
					Prairie Junegrass	5
					Sandberg bluegrass	5
					Spineless horsebrush	5
					Threadleaf sedge	5
					Winterfat	5
					Yellow rabbitbrush	5

# Rangeland Productivity and Plant Composition

Carbon County Area, Wyoming

Map symbol and soil name	Ecological site	Total dry-weight production			Characteristic vegetation	Rangeland composition
		Favorable year	Normal year	Unfavorable year		
		Lb/Ac	Lb/Ac	Lb/Ac	Pct	
260: Rock River	SANDY (10-14SE)	1,500	1,200	700	Needleandthread	25
					Streambank wheatgrass	15
					Big sagebrush	10
					Bluebunch wheatgrass	10
					Canby bluegrass	10
					Indian ricegrass	10
					Bottlebrush squirreltail	5
					Truckee rabbitbrush	5
261: Luhon	SHALLOW LOAMY (10-14 SE)	1,500	1,200	700	Other perennial grasses	25
					Streambank wheatgrass	20
					Other perennial forbs	15
					Big sagebrush	10
					Bluebunch wheatgrass	10
					Needleandthread	10
					Other shrubs	10
Rock River	LOAMY (10-14SE)	1,400	1,100	600	Western wheatgrass	35
					Needleandthread	15
					Big sagebrush	10
					Bluebunch wheatgrass	10
					Blue grama	5
					Canby bluegrass	5
					Indian ricegrass	5
					Truckee rabbitbrush	5

# Rangeland Productivity and Plant Composition

Carbon County Area, Wyoming

Map symbol and soil name	Ecological site	Total dry-weight production			Characteristic vegetation	Rangeland composition
		Favorable year	Normal year	Unfavorable year		
		Lb/Ac	Lb/Ac	Lb/Ac		Pct
262:						
Rentsac	VERY SHALLOW (10-14SE)	600	450	250	—	—
Thermopolis	SHALLOW LOAMY (10-14 SE)	1,200	900	700	Bluebunch wheatgrass	20
					Western wheatgrass	20
					Needleandthread	10
					Big sagebrush	5
					Indian ricegrass	5
					Prairie Junegrass	5
263:						
Edlin	SANDY (10-14SE)	1,500	1,200	700	Needleandthread	25
					Streambank wheatgrass	20
					Indian ricegrass	15
					Big sagebrush	5
					Bluebunch wheatgrass	5
					Bottlebrush squirreltail	5
					Silver sagebrush	5
					Threadleaf sedge	5
Carmody	SANDY (10-14SE)	1,500	1,200	700	—	—

# Rangeland Productivity and Plant Composition

Carbon County Area, Wyoming

Map symbol and soil name	Ecological site	Total dry-weight production			Characteristic vegetation	Rangeland composition
		Favorable year	Normal year	Unfavorable year		
		Lb/Ac	Lb/Ac	Lb/Ac		Pct
264: Rentsac	SHALLOW LOAMY (10-14 SE)	1,000	800	500	Bluebunch wheatgrass	50
					Needleandthread	15
					Western wheatgrass	10
					Blue grama	5
					Other perennial forbs	5
					Other perennial grasses	5
					Other shrubs	5
Rock outcrop	—	—	—	—	—	—
272: Rawlins	SHALLOW SANDY (10-14SE)	1,200	900	700	—	—
275: Poposhia	LOAMY (10-14SE)	1,400	1,100	600	—	—
Chaperton	LOAMY (10-14SE)	1,400	1,100	600	Western wheatgrass	35
					Needleandthread	15
					Big sagebrush	10
					Prairie Junegrass	5
					Sandberg bluegrass	5



# Rangeland Productivity and Plant Composition

Carbon County Area, Wyoming

Map symbol and soil name	Ecological site	Total dry-weight production			Characteristic vegetation	Rangeland composition
		Favorable year	Normal year	Unfavorable year		
		Lb/Ac	Lb/Ac	Lb/Ac	Pct	
278: Ryan Park	SANDY (10-14SE)	1,500	1,200	700	Needleandthread	30
					Streambank wheatgrass	15
					Indian ricegrass	10
					Plains reedgrass	5
					Prairie Junegrass	5
					Sandberg bluegrass	5
					Spineless horsebrush	5
					Threadleaf sedge	5
					Winterfat	5
					Yellow rabbitbrush	5
Elk Mountain	SANDY (10-14SE)	1,500	1,200	700	Needleandthread	30
					Streambank wheatgrass	15
					Indian ricegrass	10
					Plains reedgrass	5
					Prairie Junegrass	5
					Sandberg bluegrass	5
					Spineless horsebrush	5
					Threadleaf sedge	5
					Truckee rabbitbrush	5
					Winterfat	5

# Rangeland Productivity and Plant Composition

Carbon County Area, Wyoming

Map symbol and soil name	Ecological site	Total dry-weight production			Characteristic vegetation	Rangeland composition
		Favorable year	Normal year	Unfavorable year		
		Lb/Ac	Lb/Ac	Lb/Ac	Pct	
279: Blackhall	SHALLOW SANDY (10-14SE)	1,200	900	700	Needleandthread	25
					Bluebunch wheatgrass	20
					Sedge	15
					Black sagebrush	10
					Indian ricegrass	10
					Muttongrass	10
					Western wheatgrass	10
					Big sagebrush	5
					Prairie Junegrass	5
Grieves	SANDY (10-14SE)	1,500	1,200	700	Needleandthread	25
					Streambank wheatgrass	15
					Big sagebrush	10
					Bluebunch wheatgrass	10
					Canby bluegrass	10
					Indian ricegrass	10
					Bottlebrush squirreltail	5
					Other perennial forbs	5
					Other perennial grasses	5
					Truckee rabbitbrush	5
280: Hazton variant	ROCKY HILLS (15-19SE)	1,150	900	550	—	—
Baggott variant	SHALLOW LOAMY (15-19SE)	1,400	1,100	800	—	—

# Rangeland Productivity and Plant Composition

Carbon County Area, Wyoming

Map symbol and soil name	Ecological site	Total dry-weight production			Characteristic vegetation	Rangeland composition
		Favorable year	Normal year	Unfavorable year		
		Lb/Ac	Lb/Ac	Lb/Ac		Pct
282: Tisworth	SALINE LOWLAND (10-14SE)	2,500	1,800	1,200	Alkali sacaton Basin wildrye Greasewood Western wheatgrass Fourwing saltbush Inland saltgrass Winterfat	30 15 15 10 5 5 5
284: Blackhall	SHALLOW BREAKS (10-14SE)	1,200	1,000	800	Utah juniper Bluebunch wheatgrass Needleandthread Big sagebrush Indian ricegrass Prairie Junegrass Western wheatgrass	45 15 15 5 5 5 5
Garmody	SHALLOW BREAKS (10-14SE)	1,300	1,100	800	Utah juniper Bluebunch wheatgrass Needleandthread Big sagebrush Indian ricegrass Prairie Junegrass Western wheatgrass	45 15 15 5 5 5 5
Rock outcrop	---	---	---	---	---	---

# Rangeland Productivity and Plant Composition

Carbon County Area, Wyoming

Map symbol and soil name	Ecological site	Total dry-weight production			Characteristic vegetation	Rangeland composition
		Favorable year	Normal year	Unfavorable year		
		Lb/Ac	Lb/Ac	Lb/Ac		Pct
286: Tisworth	SALINE UPLAND (10-14SE)	650	500	300	Fourwing saltbush	50
					Streambank wheatgrass	15
					Indian ricegrass	10
					Winterfat	10
					Bottlebrush squirreltail	5
					Greasewood	5
					Other perennial forbs	5
296: Pinell	CLAYEY (10-14SE)	1,400	1,100	600	Streambank wheatgrass	40
					Big sagebrush	10
					Needleandthread	10
					Bluebunch wheatgrass	5
					Green needlegrass	5
					Needleleaf sedge	5
					Plains reedgrass	5
					Prairie Junegrass	5
					Sandberg bluegrass	5
Boettcher	CLAYEY (10-14SE)	1,400	1,200	800	Western wheatgrass	35
					Green needlegrass	25
					Big sagebrush	5
					Bluebunch wheatgrass	5
					Sandberg bluegrass	5
					Unknowns	5

# Rangeland Productivity and Plant Composition

Carbon County Area, Wyoming

Map symbol and soil name	Ecological site	Total dry-weight production			Characteristic vegetation	Rangeland composition
		Favorable year	Normal year	Unfavorable year		
		Lb/Ac	Lb/Ac	Lb/Ac		Pct
332: Chaperton, dry	LOAMY (7-9GR)	700	500	300	Western wheatgrass	25
					Big sagebrush	10
					Needleandthread	10
					Prairie Junegrass	10
					Sandberg bluegrass	10
Hatermus	SALINE UPLAND (7-9GR)	450	350	200	Bluebunch wheatgrass	30
					Streambank wheatgrass	15
					Indian ricegrass	10
					Sandberg bluegrass	10
					Big sagebrush	5
					Black sagebrush	5
					Needleandthread	5
					Needleleaf sedge	5
Haterton	SHALLOW LOAMY (7-9GR)	450	350	200	Bluebunch wheatgrass	30
					Streambank wheatgrass	15
					Fourwing saltbush	10
					Indian ricegrass	10
					Big sagebrush	5
					Black sagebrush	5
					Needleandthread	5
					Needleleaf sedge	5

# Rangeland Productivity and Plant Composition

Carbon County Area, Wyoming

Map symbol and soil name	Ecological site	Total dry-weight production			Characteristic vegetation	Rangeland composition
		Favorable year	Normal year	Unfavorable year		
		Lb/Ac	Lb/Ac	Lb/Ac	Pct	
333: Sagecreek, alkali	SALINE UPLAND (7-9GR)	600	450	300	Fourwing saltbush	35
					Bottlebrush squirreltail	20
					Indian ricegrass	15
					Western wheatgrass	15
					Needleandthread	5
					Sandberg bluegrass	5
Sagecreek	LOAMY (7-9GR)	700	500	300	Streambank wheatgrass	30
					Needleandthread	20
					Big sagebrush	10
					Indian ricegrass	10
					Bluebunch wheatgrass	5
					Fourwing saltbush	5
					Prairie Junegrass	5
					Sandberg bluegrass	5
					Truckee rabbitbrush	5
					Winterfat	5
334: Sagecreek, alkali	SALINE UPLAND (7-9GR)	600	450	300	Fourwing saltbush	35
					Bottlebrush squirreltail	20
					Indian ricegrass	15
					Western wheatgrass	15
					Needleandthread	5
					Sandberg bluegrass	5

# Rangeland Productivity and Plant Composition

Carbon County Area, Wyoming

Map symbol and soil name	Ecological site	Total dry-weight production			Characteristic vegetation	Rangeland composition
		Favorable year	Normal year	Unfavorable year		
		Lb/Ac	Lb/Ac	Lb/Ac	Pct	
336:						
Haterton, thin solum	SHALLOW LOAMY (7-9GR)	450	350	200	Bluebunch wheatgrass	30
					Streambank wheatgrass	15
					Fourwing saltbush	10
					Indian ricegrass	10
					Big sagebrush	5
					Black sagebrush	5
					Needleandthread	5
					Needleleaf sedge	5
Hatermus	SALINE UPLAND (7-9GR)	600	450	300	—	—
Haterton	SHALLOW LOAMY (7-9GR)	450	350	200	Bluebunch wheatgrass	30
					Streambank wheatgrass	15
					Fourwing saltbush	10
					Indian ricegrass	10
					Big sagebrush	5
					Black sagebrush	5
					Needleandthread	5
					Needleleaf sedge	5
380:						
Hazion variant	ROCKY HILLS (15-19SE)	1,150	900	550	—	—
Burgess	LOAMY (15-19SE)	2,000	1,500	800	—	—
400:						
Firth variant	LOWLAND (10-14SE)	3,000	2,300	1,600	—	—

# Rangeland Productivity and Plant Composition

Carbon County Area, Wyoming

Map symbol and soil name	Ecological site	Total dry-weight production			Characteristic vegetation	Rangeland composition
		Favorable year	Normal year	Unfavorable year		
		Lb/Ac	Lb/Ac	Lb/Ac		Pct
400: Canburn variant	WETLAND (10-14SE)	6,000	5,000	3,500	Nebraska sedge	35
					Northern reedgrass	10
					Tufted hairgrass	10
					Arrowgrass	5
					Willow	5
					Iris	1
483: Sandbranch	SALINE UPLAND (7-9GR)	600	450	300	Fourwing saltbush	50
					Bottlebrush squirreltail	10
					Indian ricegrass	10
					Bud sagebrush	5
					Greasewood	5
					Streambank wheatgrass	5
495: Chaperton, dry	LOAMY (7-9GR)	700	500	300	Western wheatgrass	25
					Big sagebrush	10
					Needleandthread	10
					Prairie Junegrass	10
					Sandberg bluegrass	10



# Rangeland Productivity and Plant Composition

Carbon County Area, Wyoming

Map symbol and soil name	Ecological site	Total dry-weight production			Characteristic vegetation	Rangeland composition
		Favorable year	Normal year	Unfavorable year		
		Lb/Ac	Lb/Ac	Lb/Ac	Pct	
495: Sagecreek	LOAMY (7-9GR)	700	500	300	Streambank wheatgrass	30
					Needleandthread	20
					Big sagebrush	10
					Indian ricegrass	10
					Bluebunch wheatgrass	5
					Fourwing saltbush	5
					Prairie Junegrass	5
					Sandberg bluegrass	5
					Truckee rabbitbrush	5
					Winterfat	5
502: Hagga, saline, alkali	SALINE SUBIRRIGATED (10-14SE)	2,500	2,000	1,500	Western wheatgrass	40
					Sedge	25
					Basin wildrye	5
					Rush	5
					Slender wheatgrass	5
703: Havre	LOWLAND (10-14SE)	3,000	2,300	1,600	---	---
761: Glendive variant	LOWLAND (10-14SE)	3,000	2,300	1,600	---	---

# Rangeland Productivity and Plant Composition

Carbon County Area, Wyoming

Map symbol and soil name	Ecological site	Total dry-weight production			Characteristic vegetation	Rangeland composition
		Favorable year	Normal year	Unfavorable year		
		Lb/Ac	Lb/Ac	Lb/Ac		Pct
911:						
Forelle	LOAMY (10-14SE)	1,400	1,100	600	Western wheatgrass	40
					Big sagebrush	10
					Needleandthread	10
					Bluebunch wheatgrass	5
					Green needlegrass	5
					Needleleaf sedge	5
					Plains reedgrass	5
					Prairie Junegrass	5
					Sandberg bluegrass	5
Diamondville	LOAMY (10-14SE)	1,400	1,100	600	Western wheatgrass	30
					Needleandthread	15
					Big sagebrush	10
					Bluebunch wheatgrass	10
					Green needlegrass	5
					Muttongrass	5
					Yellow rabbitbrush	5

# Rangeland Productivity and Plant Composition

Carbon County Area, Wyoming

Map symbol and soil name	Ecological site	Total dry-weight production			Characteristic vegetation	Rangeland composition
		Favorable year	Normal year	Unfavorable year		
		Lb/Ac	Lb/Ac	Lb/Ac	Pct	
912: Evanston	LOAMY (10-14SE)	1,400	1,100	600	Streambank wheatgrass	20
					Big sagebrush	15
					Needleandthread	15
					Bluebunch wheatgrass	10
					Canby bluegrass	10
					Letterman's needlegrass	10
					Indian ricegrass	5
					Other perennial forbs	5
					Other perennial grasses	5
					Prairie Junegrass	5
928: Grievess variant	LOWLAND (10-14SE)	3,000	2,300	1,600	Western wheatgrass	20
					Basin wildrye	10
					Narrowleaf cottonwood	10
					Needleandthread	10
					Silver sagebrush	10
					Big sagebrush	5
					Canby bluegrass	5
					Indian ricegrass	5
					Prairie Junegrass	5
					Yellow rabbitbrush	5

# Rangeland Productivity and Plant Composition

Carbon County Area, Wyoming

Map symbol and soil name	Ecological site	Total dry-weight production			Characteristic vegetation	Rangeland composition
		Favorable year	Normal year	Unfavorable year		
		Lb/Ac	Lb/Ac	Lb/Ac		Pct
928: Gerrard	WETLAND (10-14SE)	3,700	3,100	2,500	Tufted hairgrass	30
					Slender wheatgrass	20
					Nebraska sedge	15
					Bluejoint	10
					Western wheatgrass	10
					Baltic rush	5
931: Forelle	LOAMY (10-14SE)	1,400	1,100	600	Western wheatgrass	40
					Big sagebrush	10
					Needleandthread	10
					Bluebunch wheatgrass	5
					Green needlegrass	5
					Needleleaf sedge	5
					Plains reedgrass	5
					Prairie Junegrass	5
					Sandberg bluegrass	5
1202: Delplain variant	SHALE (10-14SE)	400	300	200	---	---
Morling	SHALE (10-14SE)	400	300	200	---	---

# Rangeland Productivity and Plant Composition

Carbon County Area, Wyoming

Map symbol and soil name	Ecological site	Total dry-weight production			Characteristic vegetation	Rangeland composition
		Favorable year	Normal year	Unfavorable year		
		Lb/Ac	Lb/Ac	Lb/Ac	Pct	
1209: Zillman	COARSE UPLAND (15-19SE)	1,200	800	500	Bluebunch wheatgrass	30
					Needleandthread	15
					Black sagebrush	10
					Bottlebrush squirreltail	10
					Streambank wheatgrass	10
					Antelope bitterbrush	5
					Big sagebrush	5
					Other perennial forbs	5
					Other perennial grasses	5
					Sandberg bluegrass	5
Peyton variant	LOAMY (15-19SE)	2,200	1,600	1,100	Bluebunch wheatgrass	25
					Western wheatgrass	25
					Green needlegrass	15
					Needleandthread	10
					Little bluestem	5
					Other perennial grasses	5
					Other shrubs	5

# Rangeland Productivity and Plant Composition

Carbon County Area, Wyoming

Map symbol and soil name	Ecological site	Total dry-weight production			Characteristic vegetation	Rangeland composition
		Favorable year	Normal year	Unfavorable year		
		Lb/Ac	Lb/Ac	Lb/Ac		Pct
1217: Zillman variant	COARSE UPLAND (15-19SE)	1,600	1,200	800	Bluebunch wheatgrass Big sagebrush Western wheatgrass Antelope bitterbrush Canby bluegrass Indian ricegrass Needleandthread Penstemon Serviceberry Spiny phlox	15 10 10 5 5 5 5 1 1 1
Highpoint	GRAVELLY (10-14SE)	650	450	300	—	—
1251: McFadden	SHALLOW SANDY (10-14SE)	1,200	900	700	—	—
Blackhall	SHALLOW SANDY (10-14SE)	1,200	900	700	—	—
Edlin	SANDY (10-14SE)	1,500	1,200	700	Needleandthread Streambank wheatgrass Indian ricegrass Big sagebrush Bluebunch wheatgrass Bottlebrush squirreltail Silver sagebrush Threadleaf sedge	25 20 15 5 5 5 5 5

# Rangeland Productivity and Plant Composition

Carbon County Area, Wyoming

Map symbol and soil name	Ecological site	Total dry-weight production			Characteristic vegetation	Rangeland composition
		Favorable year	Normal year	Unfavorable year		
		Lb/Ac	Lb/Ac	Lb/Ac	Pct	
1252: Rentsac	VERY SHALLOW (10-14SE)	600	450	250	Bluebunch wheatgrass	50
					Needleandthread	15
					Western wheatgrass	10
					Blue grama	5
					Other perennial forbs	5
					Other perennial grasses	5
					Other shrubs	5
Blazon	SHALE (10-14SE)	400	300	200	---	---
Rubble land	---	---	---	---	---	---
1255: Blackhall	SHALLOW SANDY (10-14SE)	1,200	900	700	Needleandthread	25
					Bluebunch wheatgrass	20
					Sedge	15
					Black sagebrush	10
					Indian ricegrass	10
					Muttongrass	10
					Western wheatgrass	10
					Big sagebrush	5
					Prairie Junegrass	5
Rentsac	VERY SHALLOW (10-14SE)	600	450	250	---	---
1256: Rawlins	SHALLOW SANDY (10-14SE)	1,200	900	700	---	---

# Rangeland Productivity and Plant Composition

Carbon County Area, Wyoming

Map symbol and soil name	Ecological site	Total dry-weight production			Characteristic vegetation	Rangeland composition
		Favorable year	Normal year	Unfavorable year		Pct
		Lb/Ac	Lb/Ac	Lb/Ac		
1256:						
Rock River	LOAMY (10-14SE)	1,400	1,100	600	Western wheatgrass	35
					Needleandthread	15
					Big sagebrush	10
					Bluebunch wheatgrass	10
					Blue grama	5
					Canby bluegrass	5
					Indian ricegrass	5
					Truckee rabbitbrush	5
1260:						
McFadden	SHALLOW SANDY (10-14SE)	1,200	900	700	—	—
Edlin	SANDY (10-14SE)	1,500	1,200	700	Needleandthread	25
					Streambank wheatgrass	20
					Indian ricegrass	15
					Big sagebrush	5
					Bluebunch wheatgrass	5
					Bottlebrush squirreltail	5
					Silver sagebrush	5
					Threadleaf sedge	5
1912:						
Peyton variant	LOAMY (15-19SE)	2,000	1,500	800	—	—



# Rangeland Productivity and Plant Composition

Carbon County Area, Wyoming

Map symbol and soil name	Ecological site	Total dry-weight production			Characteristic vegetation	Rangeland composition
		Favorable year	Normal year	Unfavorable year		
		Lb/Ac	Lb/Ac	Lb/Ac		Pct
1912: Evanston variant	LOAMY (15-19SE)	2,000	1,500	800	Big sagebrush Bluebunch wheatgrass Idaho fescue Needleandthread Streambank wheatgrass Canby bluegrass	10 10 10 10 10 5
2080: Pinell variant	LOAMY (10-14SE)	1,400	1,100	600	Idaho fescue Streambank wheatgrass Green needlegrass Big sagebrush Needleandthread Prairie Junegrass	15 15 10 5 5 5
Forelle	LOAMY (10-14SE)	1,400	1,100	600	Western wheatgrass Big sagebrush Needleandthread Bluebunch wheatgrass Green needlegrass Needleleaf sedge Plains reedgrass Prairie Junegrass Sandberg bluegrass	40 10 10 5 5 5 5 5 5
2199: Anchutz	SALINE LOAMY (10-14SE)	900	700	500		

# Rangeland Productivity and Plant Composition

Carbon County Area, Wyoming

Map symbol and soil name	Ecological site	Total dry-weight production			Characteristic vegetation	Rangeland composition
		Favorable year	Normal year	Unfavorable year		
		Lb/Ac	Lb/Ac	Lb/Ac	Pct	
9120: Evanston variant	LOAMY (15-19SE)	2,000	1,500	800	Big sagebrush.	10
					Bluebunch wheatgrass	10
					Idaho fescue	10
					Needleandthread	10
					Streambank wheatgrass	10
					Canby bluegrass	5
Evanston	LOAMY (15-19SE)	1,800	1,500	900	Big sagebrush	10
					Needleandthread	10
					Western wheatgrass	10
					Mountain snowberry	5
					Muttongrass	5
					Prairie Junegrass	5
					Saskatoon serviceberry	5
W: Water						

**Appendix N**  
**Mesoscale Model Simulations in Quasi-Forecast Mode**  
**of the Great Western Storm of 16-20 March 2003**

## 5.3A MESOSCALE MODEL SIMULATIONS IN QUASI-FORECAST MODE OF THE GREAT WESTERN STORM OF 16-20 MARCH 2003

Douglas A. Wesley<sup>1\*</sup>, Gregory Poulos<sup>2</sup>, John Snook<sup>4</sup>, Ed Szoke<sup>5</sup>, Michael Meyers<sup>3</sup>, Greg Byrd<sup>1</sup>, Robert Rozumalski<sup>3</sup>, and Heather McIntyre<sup>1</sup>

<sup>1</sup>UCAR/COMET<sup>®</sup>, Boulder CO <sup>2</sup>NCAR/ATD <sup>3</sup>NOAA/NWS <sup>4</sup>ATMET <sup>5</sup>NOAA/FSL/CIRA

### 1. INTRODUCTION

A massive snowstorm crippled large portions of the central Rockies and adjacent plains during the period 16-20 March 2003. Snowfall accumulation in the foothills and mountains exceeded four feet in relatively large regions, while on the plains amounts above two feet were common (Fig. 1; also see Poulos et al. 2003). The large impacts of this historic storm are well documented. This paper examines experimental meso- $\gamma$  scale model simulations of the event, utilizing larger-scale model-generated boundary conditions, from a forecasting standpoint.

Public forecasts of this event were generally accurate up to several days before the storm hit. NCEP model guidance provided initial alarms (in the form of ensemble forecasts) up to one week prior to the storm (Szoké et al. 2004). As the potential event approached, Eta model forecasts were trending towards a large precipitation event, and by about two days before the onset of snowfall along Colorado's Front Range very large precipitation totals (five or more inches) were output by this model for portions of the region during the period of 17-20 March. Accuracy of these forecasts was perhaps unprecedented in the area, for such a large event, primarily because the orographic forcing was so strong. The Eta forecasts clearly provided a crucial asset towards forecast operations prior to the storm. The model, however, did show some shortcomings regarding the precipitation type distribution, and of course was limited by its relatively large grid spacing, a required feature given the domain size of that model.

The crippling nature of the subsequent storm period, in terms of disrupting transportation and other day-to-day activities, has shown that even if a very large snowfall potential is emphasized in, say, a 2-4 day forecast, society is still vulnerable to this type of storm. Insurance claims and a paralyzed international airport attest to this fact. Importantly, the current challenge is to increase the resolution and details of the forecast to minimize this vulnerability, as much as currently possible.

Close examination of snowfall totals revealed extremely sharp gradients in snowfall, on the order of several feet within a horizontal distance of 15 miles or less. Many of these sharp gradient regions coincided with strong gradients in elevation; however some did not. For example, an area on the plains/foothills interface just north of Denver accumulated only 3-6 inches of wet snowfall, while 15-25 miles to the south, 24-36 inches fell, and areas another 20 miles to the south recorded nearly four feet. Meanwhile, 20-30 miles *north* of the aforementioned area of snowfall minimum, 24-36 inches fell. *All of these locations are at the same approximate elevation.* The current configuration of NWS forecast zones along the urban corridor is not designed to handle these types of gradients, nor is the current configuration of the Eta model. As NWS forecasts evolve towards gridded forecast fields, this issue will be addressed to some degree.

The purpose of this study is to closely examine the causes of extreme snowfall and wind variations in this storm from a mesoscale modeling standpoint in order to better predict them in the future. The MM5 was run in quasi-forecast mode (with Eta forecasts initialized at 00 UTC 17 Mar.) utilizing non-hydrostatic and multiple-grid configurations, with the smallest grid exhibiting 1-2 km horizontal grid spacing. The primary reason for utilizing such a small grid spacing is the presence of steep and variable topography throughout the foothills and higher terrain of the Front Range. The "workstation" Eta was run (non-hydrostatically) utilizing Eta analyses and 3-hr. forecasts at the boundaries. The smallest grid contained 2 km grid spacing.

---

\*Corresponding author address:

Douglas A. Wesley, UCAR/COMET, PO Box 3000, Boulder CO 80307; e-mail <wesley@comet.ucar.edu>

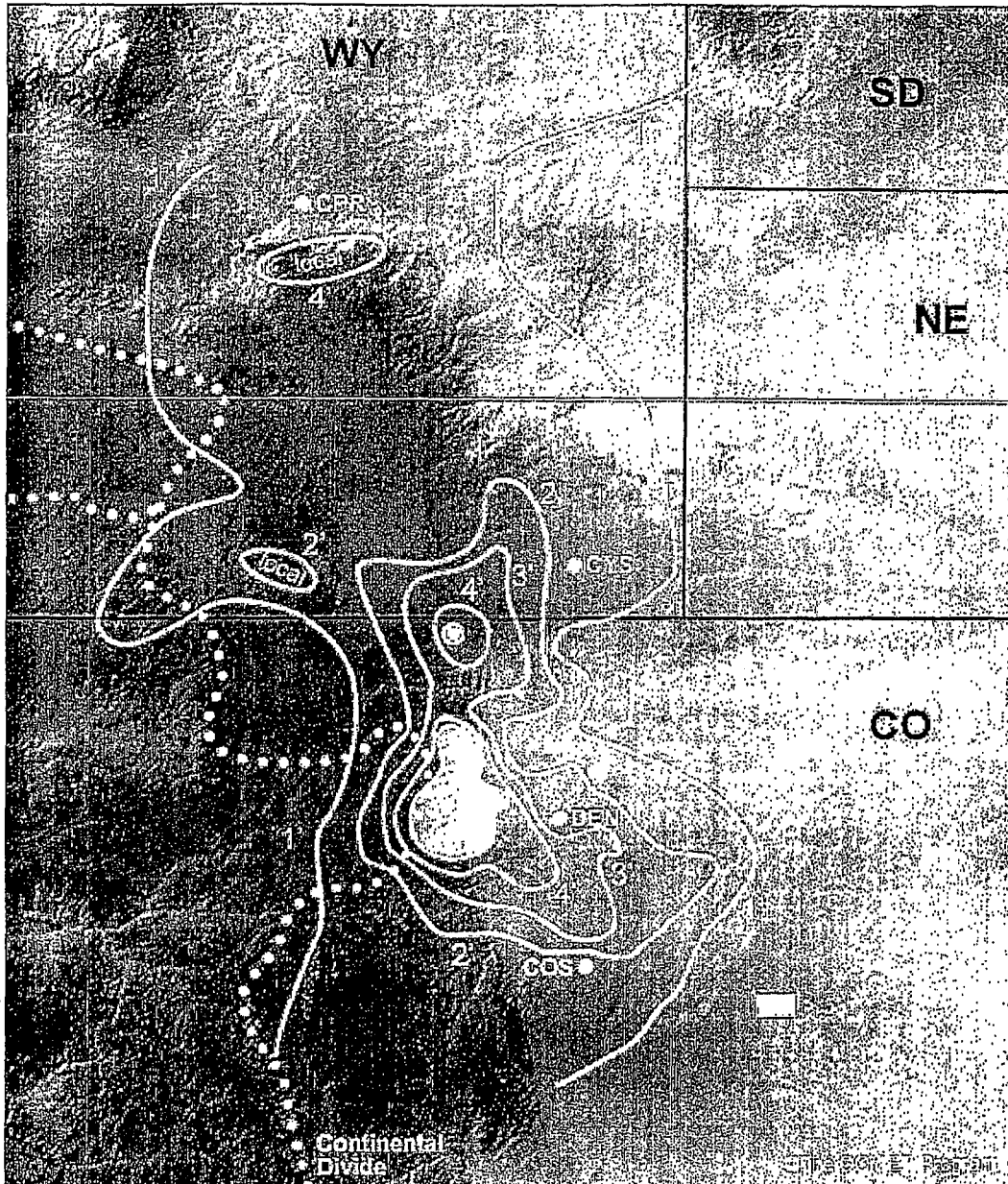


Fig. 1 Snowfall totals (in feet) for a portion of the Front Range region for 17-20 March 2003. Significant snows fell in other regions of the Rocky Mountains to the west of this area (see Meyers et al., 2004).

Preliminary indications are that both mesoscale models produce generally accurate precipitation distributions, and both produce cooler (but still above freezing) low-level conditions along the urban corridor for much of the storm evolution when compared to the operational Eta forecasts. The MM5 forecasts appear to capture better detail in the precipitation distributions, as expected, and exhibit low-level

temperatures closer to freezing in critical areas near the rain/snow line. Comparisons with operational profiler winds show some problems with the strength of the mid-level upslope, a critical component of the storm, and one perhaps related to the relatively warm low-level conditions along the urban corridor. This component is likely a primary factor in determining precipitation rates, in the sense of the warm conveyor

belt running up and over the barrier jet, and thus a critical determinant of surface precipitation type. It appears that an accurate initial analysis and subsequent prediction of the depth of the barrier jet is a crucial requirement to an accurate precipitation forecast. Another important feature of the mid-level easterly flow is its strong variation through the 3-4 day period as synoptic waves passed through the region, and these variations will be compared to the barrier jet depth and distributions of precipitation rates in the near future.

Initially it also appears that relatively subtle terrain features along the plains/foothills interface interacted with the barrier jet to contribute significantly to low-level vertical motion fields, and likely play a role in the cause of the snow minima discussed above.

## 2. STORM DYNAMICS OVERVIEW

During the period 15-17 March, significant troughing built into the central and southern Rockies and the Great Basin as intense mid- and upper-level jet energy impacted the California coast from the west-northwest. The amplification of the pattern increased rapidly as ridging built over the upper Midwest and mid-Atlantic regions. By 00 UTC 19 March, a strong, deep cutoff low pressure system was established over the southern Rockies and central/southern plains (Fig. 2). For a period of about 48 hours, a classic warm conveyor belt out in front of the cutoff set up and transported large amounts of moisture directly from the Gulf of Mexico northwestward into

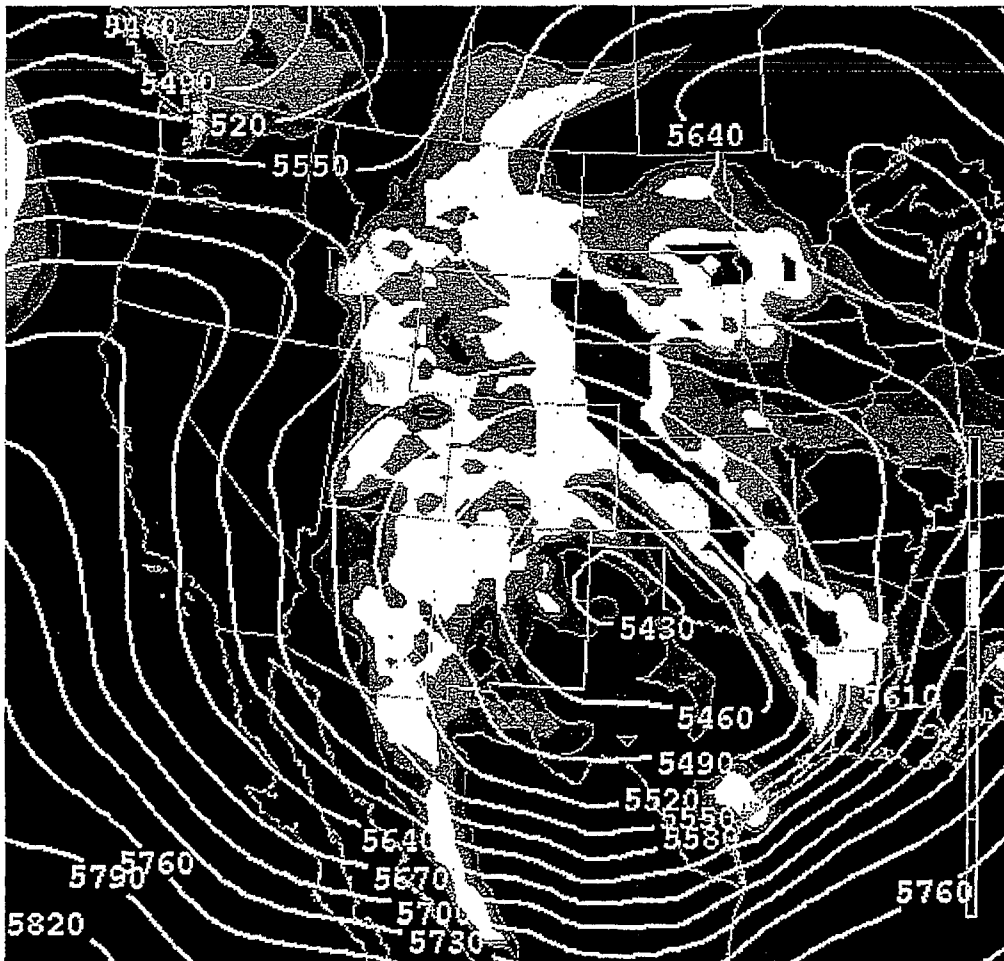


Fig. 2 500 mb heights and 700 mb RH, analyzed at 00 UTC 19 Mar. 2003. Red regions correspond to saturated conditions at 700 mb.

the central Rockies. In the northwestern portion of the cutoff system, a TROWAL-like feature set up as the occlusion matured, and this wraparound feature contributed to heavy precipitation well-removed from the cutoff center off to the southeast.

The mesoscale features of this mega-storm were of critical importance to the resulting precipitation distribution. Observationally, the role of the barrier jet in the storm in producing, first, snow instead of rain in the urban corridor, and second, uplift strong enough to produce snowfall rates of 1-3 inches per hour for 2-3 days, cannot be overemphasized. Clearly the barrier jet was located on the cold side of a persistent rain/snow boundary that exhibited the classic characteristics of strongly diabatically-forced mesoscale dynamics, a feature documented in previous heavy springtime snowfalls in the urban

corridor (Marwitz and Toth 1993). Furthermore, the three-dimensional configuration of this barrier jet is critical to the attempt to explain the astounding snowfall and wind gradients along the urban corridor. A well-developed barrier jet was apparent by 18 March, and persisted through the 19<sup>th</sup>. Important facets of this low-level northerly flow regime over and next to the foothills:

- (a) low-level northerly zone was sloped upwards to the west, essentially modifying the obstacle encountered by upslope (easterly) flow and leading to mesoscale uplift in a saturated air mass over and just east of the jet

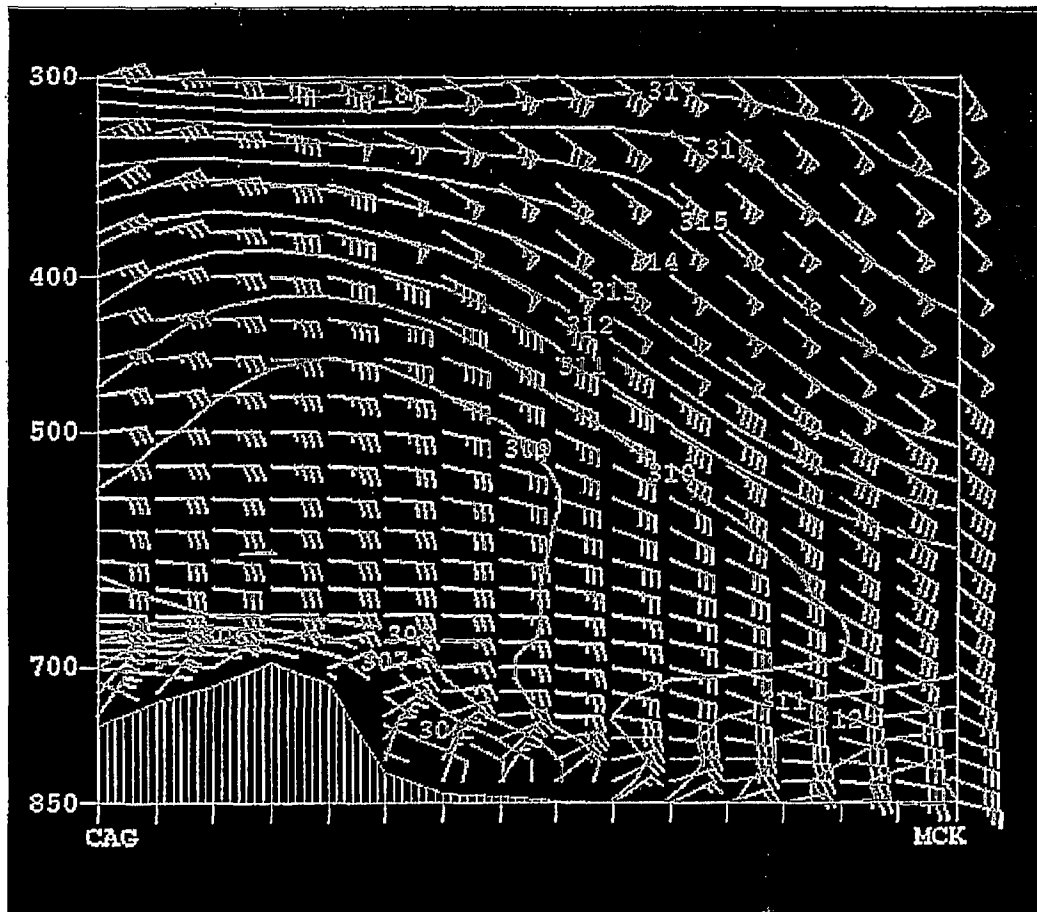


Fig. 3 Vertical cross section showing equlv. potential temp. (K) and winds (knots), 6-hr. forecast from the Eta model initialized at 18 UTC 18 Mar.

- (b) large amounts of melting in the low-levels on the east side of the barrier jet provided latent cooling, thus enhancing the blocking and barrier jet structure, similar to the March 1990 storm studied by Marwitz and Toth (1993) and others.
- (c) significant low-level cold advection from the north/northeast enhanced the stability in the air mass east of the terrain obstacles.

Note in Fig. 3 the cold air stacked up against the Front Range, and the moderate northerly flow within that cold air. Many regions just east of the foothills experienced surface wind gusts in the 30 to 40 knot range, causing extensive blowing and drifting snow. Interestingly, at this point a well-defined convergence line does not exist on the east side of the jet, and this was confirmed in surface observations. Convectively unstable conditions are noted over portions of the plains in Fig. 3.

### 3. Mesoscale model simulations

The MM5 was set up with a 5-grid nested configuration, the smallest domain (grid 5) centered on north-central CO and exhibiting a 1.5 km grid

spacing. Eta operational forecasts from the run initialized at 00 UTC 17 Mar. served as large-scale boundary conditions.

Fig. 4 shows the total precipitation (mm) predicted by the model through 84 hours (ending at 12 UTC 20 Mar.). Notable features are the foothills maxima in the higher terrain (but east of the Continental Divide) of Boulder and Larimer Counties (the Divide runs along the western boundaries of these two counties), with several locations predicted to have over 130 mm (more than 5 inches). Three relative minima are also very interesting:

1. northeastern Boulder Co. (less than 50 mm)
2. southeastern Larimer Co. (43.8 mm)
3. northeastern Larimer Co. (27.5 mm)

All of these regions experienced snow minima compared to observed snowfall in immediately surrounding regions of similar elevations (Fig. 1). This is best shown by examining high-resolution satellite imagery after the storm as the melting process started under sunny skies (Fig. 5).



Dataset: test RIP: rip  
Fcst: 84.00  
Total precip. since h 0  
Total precip. since h 0

Init: 0000 UTC Mon 17 Mar 03  
Valid: 1200 UTC Thu 20 Mar 03 (0600 CST Thu 20 Mar 03)

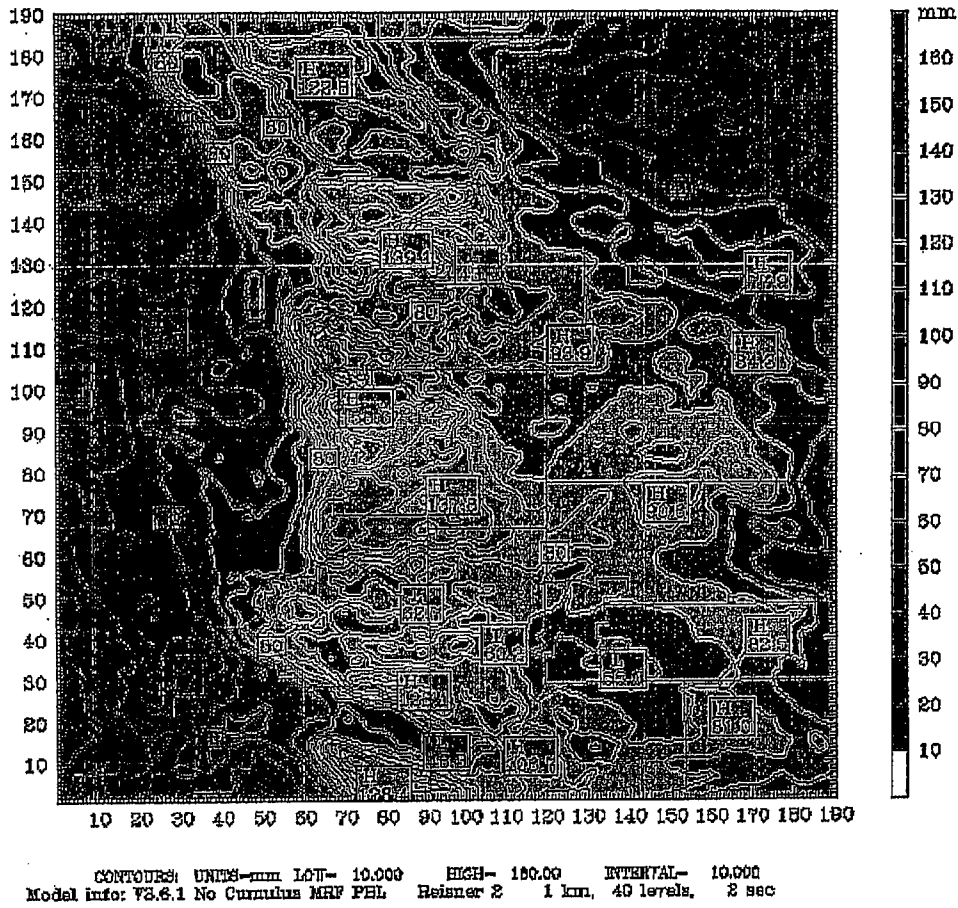


Fig. 4 MM5-predicted precipitation (mm) for 84 hours of simulations ending at 12 UTC 20 Mar..

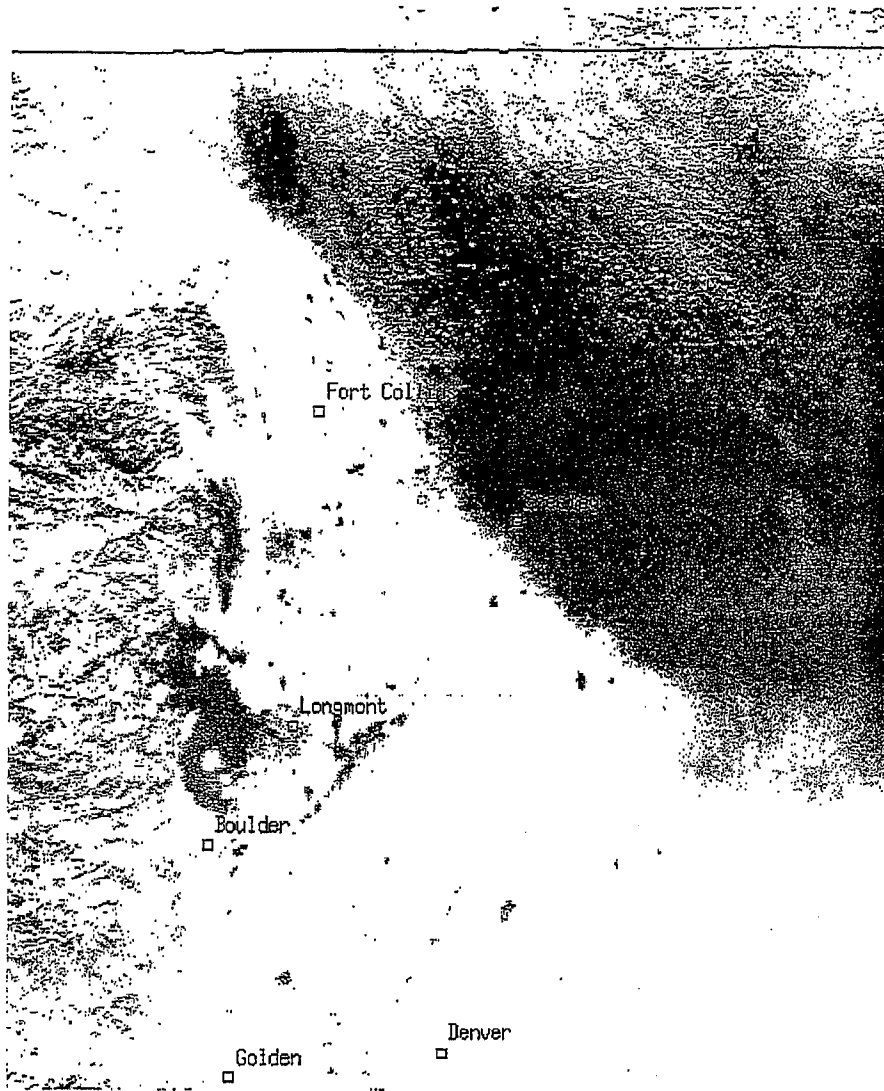


Fig. 5 High-resolution visible image (MODIS) on 22 Mar.. Complex patterns on the west side are timbered and canyon areas. Darker areas just south of the WY state line, southwest of Fort Collins and west of Longmont are areas where much less snow accumulation was observed.

Dataset: test RIP: rip  
 Fcst: 42.00  
 Temperature  
 Temperature  
 Horizontal wind vectors

Init: 0000 UTC Mon 17 Mar 03  
 Valid: 1800 UTC Tue 18 Mar 03 (1200 CST Tue 18 Mar 03)  
 at sigma = 0.999  
 at sigma = 0.999  
 at sigma = 0.999

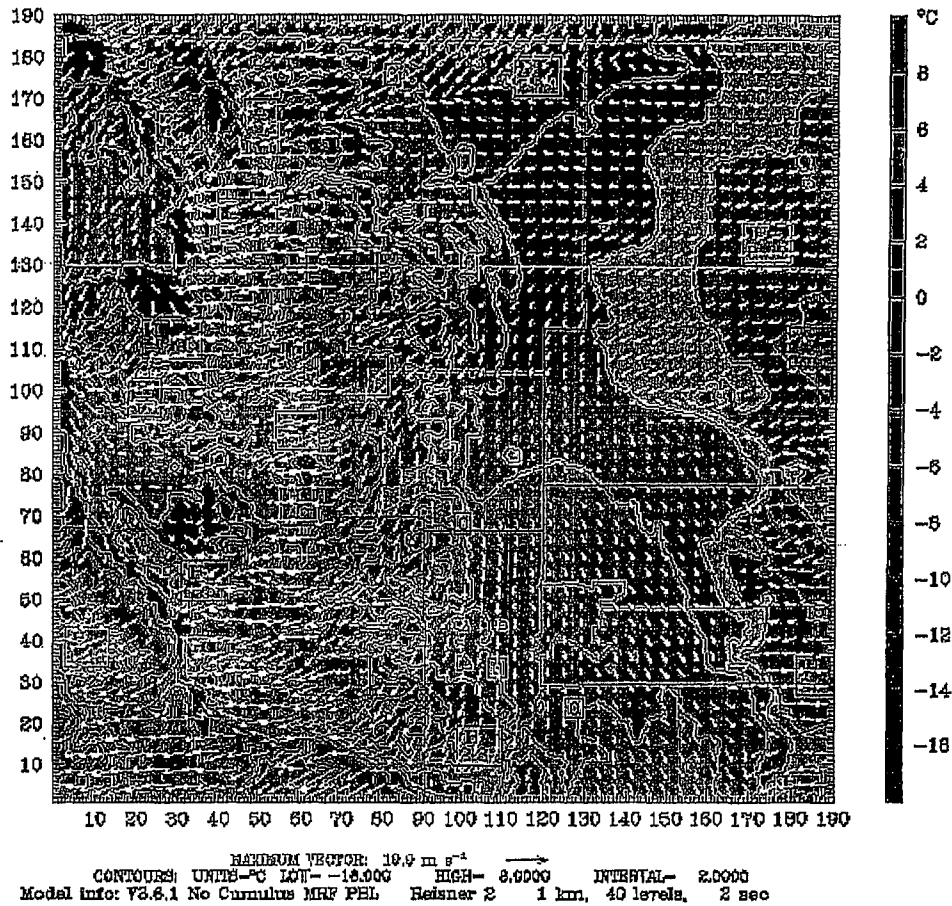


Fig. 6 MM5 42-hr. forecast of lowest level temperature (C) and winds (m/s). Note the relatively warmer areas along the foothills in southeastern Larimer Co. and northeastern Boulder Co.

Fig. 6 demonstrates several interesting aspects of the simulations. Relatively warmer conditions are predicted in general along the eastern portions of Larimer Co. and northeastern Boulder Co., in agreement with observations in two of the snow minima regions. However, in comparison with observations, these areas are predicted to be a few degrees F warmer by the model. In the urban corridor region just south of the Cheyenne Ridge, the snow minimum region discussed previously appears to be caused by lower precipitation values rather than warmer temperatures (see Wesley et al., 1995). This is often observed in storms characterized by strong north winds at the surface in this region. Also note the northerly flow over the foothills, and a strong

convergence line oriented nearly E-W along the WY border.

More results of these MM5 simulations are under investigation, including a detailed examination of the areas that experienced warmer surface conditions and less snowfall. Potential mechanisms include blocking of the barrier-jet induced cold advection by small-scale terrain features, and relatively warm air (originating over the canyons to the northwest of these locations) acting as the source region for the surface conditions over these areas.

The "workstation" Eta model was also set up non-hydrostatically, with multiple nested grid configuration and innermost grid spacing set at 2 km. Fig. 7 shows the predicted total precipitation for the 72-hr. period ending at 12 UTC 20 Mar.. Though the details in the plot do not resemble those of the MM5-predicted precipitation, especially over the eastern foothills and plains interface, note the maxima in the high terrain just east of the Continental Divide, with one elevated area in northwestern Larimer Co. exceeding 8.5". The urban corridor values are generally in the 2.25-3" range, with relatively lower values over eastern Boulder Co.. Overall, these values correlated well with observed values in a general sense, including the magnitudes of the maxima. However, some underprediction of precipitation is noted in the Fort Collins and Golden areas, and along the I-25 zone north of Denver. These issues are under further investigation, including examining the role of the diffusion processes in the Eta results.

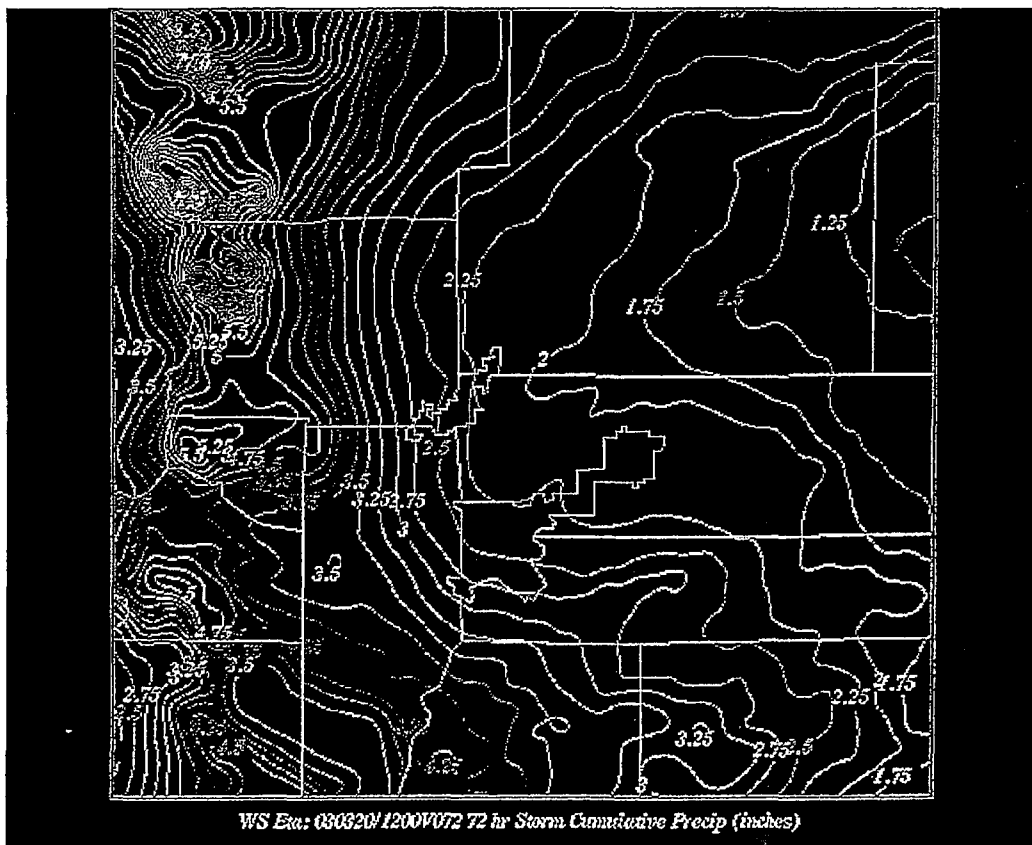


Fig. 7 High-resolution Eta predicted total precipitation (inches) for the period 12 UTC 17 Mar. through 12 UTC 20 Mar.

In regards to the precipitation type and the low-level temperature fields, the workstation Eta forecast even warmer conditions along the urban corridor than the MM5 during the storm (Fig. 8). The precipitation-type forecasts (Fig. 9) which utilize a partial-thickness approach, exhibited liquid precipitation for extreme eastern Larimer and Boulder Counties at 00 UTC 19 Mar. (at this time these areas were receiving the heaviest snowfall of the event), but do predict snowfall in some foothill/plains interface areas that were above freezing in the model through most of the storm. Note in Fig. 9 that the liquid precipitation area that extends westward over northeastern Boulder Co. has some similarity to the observed snowfall minima shown in Fig. 1. In Fig. 8, this tendency for warmer surface conditions is evident in the locations of the 2C and 3C contours over this area, especially in comparison to these locations in other areas within the urban corridor. Further examination of these thermal fields is currently underway.

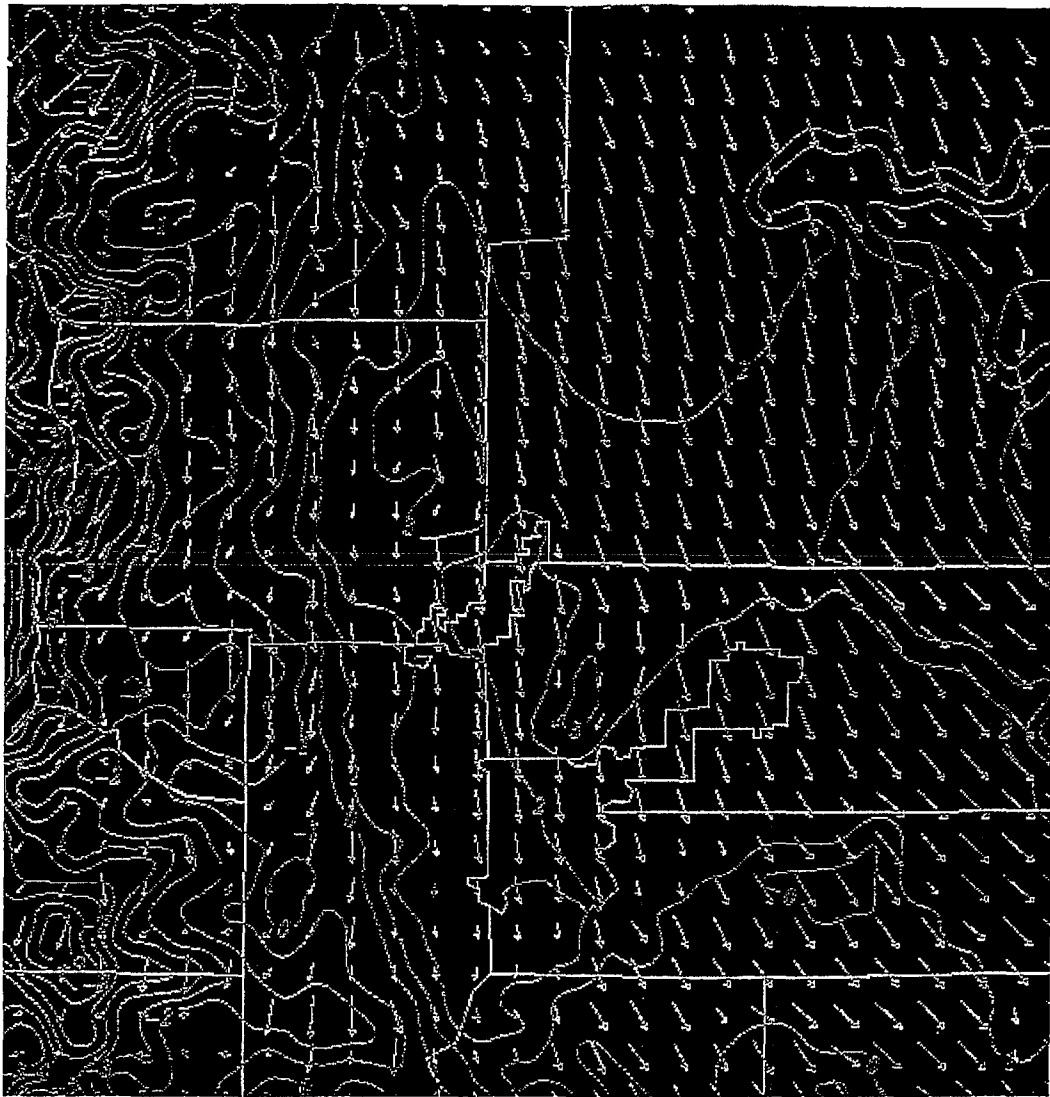


Fig. 8 High-res. Eta-forecast temperatures (C) and winds at 10m, for 00 UTC 19 Mar. The longest vector on the chart corresponds to about 25 knots.

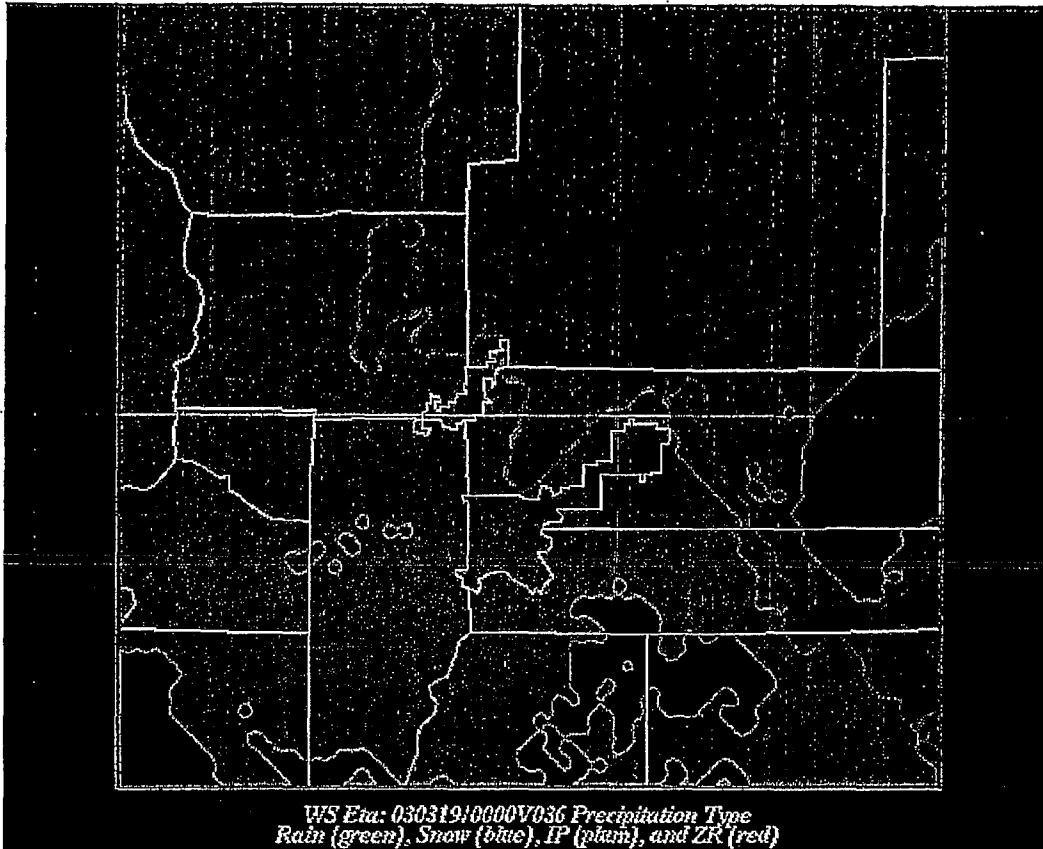


Fig. 9 Eta-forecast precipitation type, for 00 UTC 19 Mar.

The MM5 and Eta models' abilities to capture the depth and strength of the upslope flow are likely critical to the ability to predict the barrier jet regime accurately, and thus the low-level temperatures and precipitation types. This table shows a comparison of observed and predicted vertical wind speed profiles at Platteville, CO (about 25 miles north

of Denver) for the u-component at 06 UTC 19 Mar. (during the height of the storm). The "profiler" column is for the winds measured at the site. A value above 0 indicates a westerly direction.

■ Height (msl)	profiler	MM5	wEta	Eta
■ 2km	+8 knots	-2	+3	~0
■ 3	-30	-10	-4	-8
■ 4	-33	-20	-22	-15
■ 5	-31	-32	-27	-25
■ 6	-40	-40	-41	-30
■ 7	-49	-44	-42	-40

Obviously, serious issues exist with the ability of the models to predict the upslope component accurately in the 10-15,000 (MSL) foot layer. Whether this is related to the warm biases is unclear, and at first guess is non-intuitive. Another possibility is inaccurate boundary conditions.

#### 4. SUMMARY

This study has begun to address the applications of very high-resolution mesoscale model forecasts for a major wintertime snow event over the high plains and mountains of central/northern CO. This storm represented a situation where very strong synoptic forcing interacted with major terrain-forced processes to create snow accumulations above 40 inches in some urban areas and above 70 inches in many foothill locations during a 3-4 day period. In this research we have set up the MM5 and "workstation"-Eta models in quasi-forecast mode to investigate small-scale mechanisms for snowfall maxima and minima, precipitation type, and wind variations. Clearly the detailed precipitation and surface wind fields generated by the high-resolution models have produced insight into the physical processes involved, including blocking, melting, and barrier-jet induced uplift. Relatively high accuracy characterizes the total precipitation fields generated by the models. The three-dimensional nature of the barrier jet structure and the temporal dependence of the upslope forcing also represent important aspects of these simulations. The problem associated with the predicted vertical profiles of the upslope flow is under investigation. In addition, though the model forecasts seemed to accurately predict surface temperature gradients, the issue of forecast temperatures being too warm (by both models) in critical areas is also under further investigation. This is also the subject of a companion paper on this storm (Szoke et al., 2004).

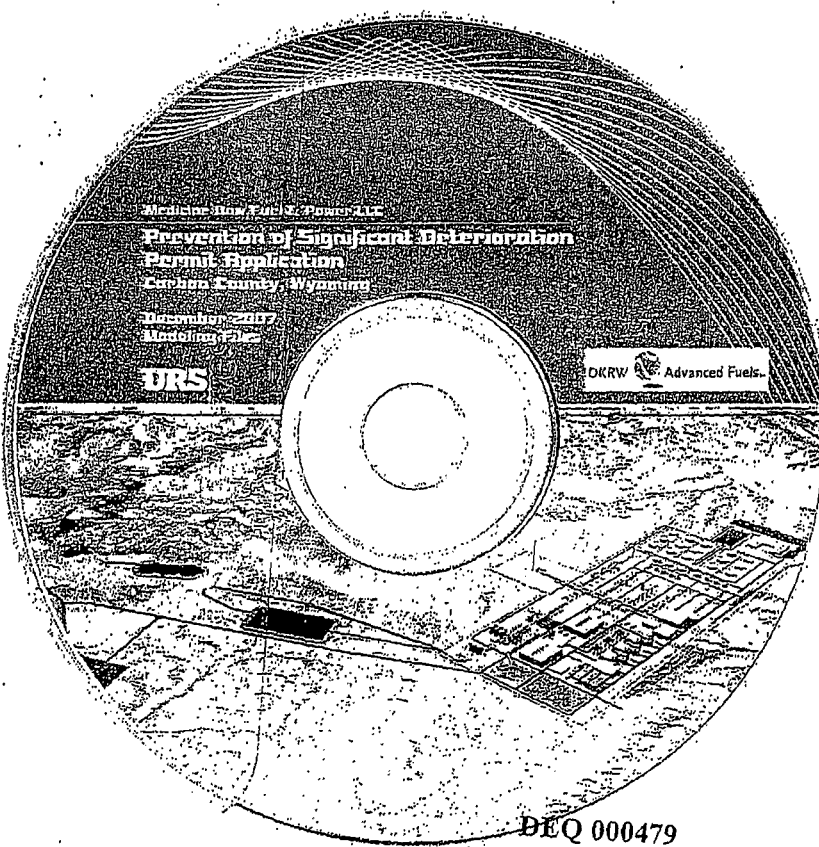
#### 5. ACKNOWLEDGEMENTS

The views expressed herein are those of the authors and do not necessarily reflect the views of UCAR or NOAA or its subagencies. This paper is funded in part by cooperative agreement #NA17WD2383 from the National Oceanic and Atmospheric Administration (NOAA). Snowfall amounts were in part supplied by NWS, cooperative, and COCORAHs observers. We thank Karl Zeller with the US Forest Service-Rocky Mountain Center, Ft. Collins, CO, for providing computer time. Model forecasts were completed using a cluster of 14 Linux nodes with AMD 2600+ dual-processors. Scott Bachmeier is thanked for providing high-resolution satellite imagery.

#### 6. REFERENCES

- Marwitz, J., and J. Toth, 1993: The Front Range Blizzard of 1990: Part I: Synoptic and mesoscale structure. *Mon. Wea. Rev.* **121**, 402-415.
- Meyers, M.P., J. Colton, R. McAnelly, W. Cotton, D. Wesley, J. Snook and G. Poulos, 2004: The Operational Implications of Forecasting a Heavy Snow Event over the Central Rockies in an Atypical Flow Regime. *Preprints, 20<sup>th</sup> Conf. on Weather Analysis and Forecasting*, Seattle, Paper P2.9.
- Poulos, G.S., D. Wesley, M. Meyers, E. Szoke, J. Snook, and G. Byrd, 2003: Exceptional Mesoscale Features of the Great Western Storm of 16-20 March 2003. *Preprints, 10<sup>th</sup> Conf. on Mesoscale Processes*, Portland, Oregon, Paper 6.6A, 6 pp..
- Szoke, E. J., B. Shaw and P. Schultz, 2004: Performance of various operational and experimental numerical forecasts for the March 2003 Colorado snowstorm. *Preprints, 20<sup>th</sup> Conf. on Weather Analysis and Forecasting*, Seattle, Paper 10.3A.
- Wesley, D.A., R.M. Rasmussen, and B.C. Bernstein, 1995: Snowfall associated with a terrain-generated convergence zone during the Winter Icing and Storms Project. *Mon. Wea. Rev.*, **123**, 2957-2977.





DEQ 000479